

Standing Seam Roof Details

INDEX OF DRAWINGS

GENERAL DETAILS

MT_SSRP_1001 - Standing Seam Panel
 MT_SSRP_1002 - Standing Seam Panel (Isometric)
 MT_SSRP_1003 - Standing Seam Panel (DASS)
 MT_SSRP_1004 - DASS Panel (Isometric)
 MT_SSRP_1005 - Standing Seam Panel (RCSS)
 MT_SSRP_1006 - RCSS Panel (Isometric)
 MT_SSRP_1007 - Snap Seam Panel
 MT_SSRP_1008 - Snap Seam Panel (Isometric)
 MT_SSRP_1009 - Standing Seam Clips
 MT_SSRP_1010 - Seam Sealant Application Detail
 MT_SSRP_1011 - SS Panel Section - Sliding Clip
 MT_SSRP_1012 - SS Panel - Double Welt Transverse
 MT_SSRP_1013 - SS Panel - Single Welt Transverse
 MT_SSRP_1014 - SS Panel Fixing Clip Area
 MT_SSRP_1015 - SS Panel Clip Layout on Radius Roof
 MT_SSRP_1016 - SS Panel Clip Layout 1
 MT_SSRP_1017 - SS Panel Clip Layout 2
 MT_SSRP_1018 - SS Panel Clip Layout 3
 MT_SSRP_1019 - SS Panel Clip Layout 4

RIDGE DETAILS

MT_SSRP_1101 - Mono Pitch Ridge - Option 1
 MT_SSRP_1102 - Mono Pitch Ridge - Option 2
 MT_SSRP_1103 - Mono Pitch Ridge - Option 3
 MT_SSRP_1104 - Mono Pitch Ridge - Option 4
 MT_SSRP_1105 - Mono Pitch Ridge - Option 5
 MT_SSRP_1106 - Mono Pitch Ridge - Option 6
 MT_SSRP_1107 - Ridge W/Offset Slope
 MT_SSRP_1108 - Hip/Ridge Detail - Option 1
 MT_SSRP_1109 - Hip/Ridge Detail - Option 2
 MT_SSRP_1110 - Hip/Ridge Detail - Option 3
 MT_SSRP_1111 - Ridge W/Z-Support - Option 1
 MT_SSRP_1112 - Ridge W/Z-Support - Option 2
 MT_SSRP_1113 - Ridge W/Z-Support - Option 3
 MT_SSRP_1114 - Ridge W/J-Support - Option 1
 MT_SSRP_1115 - Heavy Duty Ventilated Ridge

EAVE DETAILS

MT_SSRP_1201 - Typical Eave Section
 MT_SSRP_1202 - Fascia - Option 1
 MT_SSRP_1203 - Fascia - Option 2
 MT_SSRP_1204 - Fascia - Option 3
 MT_SSRP_1205 - Fascia - Option 4
 MT_SSRP_1206 - Eave With Gutter - Option 1
 MT_SSRP_1207 - Eave With Gutter - Option 2
 MT_SSRP_1208 - Eave With Gutter - Option 3
 MT_SSRP_1209 - Built In Gutter - Option 1
 MT_SSRP_1210 - Built In Gutter - Option 2
 MT_SSRP_1211 - Built In Gutter - Option 3

VALLEY DETAILS

MT_SSRP_1301 - Typical Valley Section
 MT_SSRP_1302 - Valley Detail - Option 1
 MT_SSRP_1303 - Valley Detail - Option 2
 MT_SSRP_1304 - Valley Detail - Option 3
 MT_SSRP_1305 - Valley Detail - 8:12 Or Less
 MT_SSRP_1306 - Valley Detail - 8:12 Or Greater

RAKE DETAILS

MT_SSRP_1401 - Rake Edge - Option 1
 MT_SSRP_1402 - Rake Edge - Option 2
 MT_SSRP_1403 - Rake Edge - Option 3
 MT_SSRP_1404 - Rake Edge - Option 4
 MT_SSRP_1405 - Rake Edge - Option 5
 MT_SSRP_1406 - Rake Edge - Option 6
 MT_SSRP_1407 - Rake Edge - Option 7
 MT_SSRP_1408 - Rake Edge - Option 8

WALL DETAILS

MT_SSRP_1501 - Side Wall - Option 1
 MT_SSRP_1502 - Side Wall - Option 2
 MT_SSRP_1503 - Head Wall - Option 1
 MT_SSRP_1504 - Head Wall - Option 2
 MT_SSRP_1505 - Head Wall - Option 3
 MT_SSRP_1506 - Head Wall - Option 4
 MT_SSRP_1507 - Head Wall - Option 5
 MT_SSRP_1508 - Wall To Sill Transition - Option 1
 MT_SSRP_1509 - Wall To Sill Transition - Option 2
 MT_SSRP_1510 - End Wall Cricket Option
 MT_SSRP_1511 - Masonry Wall Cricket Option
 MT_SSRP_1512 - End Wall Gutter Option
 MT_SSRP_1513 - Masonry Side Wall - Option 1
 MT_SSRP_1514 - Masonry Side Wall - Option 2
 MT_SSRP_1515 - Masonry Head Wall - Option 1
 MT_SSRP_1516 - Masonry Head Wall - Option 2

SOFFIT DETAILS

MT_SSRP_1601 - Soffit Detail - Option 1
 MT_SSRP_1602 - Soffit Detail - Option 2
 MT_SSRP_1603 - Soffit Detail - Option 3
 MT_SSRP_1604 - Soffit Detail - Option 4

PARAPET DETAILS

MT_SSRP_1701 - Parapet Detail - Option 1
 MT_SSRP_1702 - Parapet Detail - Option 2
 MT_SSRP_1703 - Parapet Detail - Option 3

SKYLIGHT DETAILS

MT_SSRP_1801 - Bottom Of Skylight
 MT_SSRP_1802 - Side Of Skylight
 MT_SSRP_1803 - Top Of Skylight
 MT_SSRP_1804 - Flat Pattern Of Apron Pan
 MT_SSRP_1805 - Skylight Panel Layout - Plan View
 MT_SSRP_1805 - Skylight Panel Layout - Isometric View

MISCELLANEOUS DETAILS

MT_SSRP_1901 - Roof Penetration - Option 1
 MT_SSRP_1902 - Roof Penetration - Option 2
 MT_SSRP_1903 - Roof Penetration - Option 3
 MT_SSRP_1904 - Roof Step - Option 1
 MT_SSRP_1905 - Roof Step - Option 2
 MT_SSRP_1906 - Roof Step - Option 3

NOTE:

Information and details are only a baseline for system and installation. Modification to meet project requirement is the responsibility of the designer, architect and contractor. MetalTech-USA project staff are available to assist throughout the design and build process. © 2011 MetalTech-USA. All rights reserved.

UNLESS OTHERWISE SPECIFIED DIMENSIONS ARE IN INCHES	DRAWING NAME: INDEX		REVISION NO: A	DATED CREATED: 6/17/2015
	DWG NO: MT_SSRP_0000		CHECKED BY: THENDERSON	APPROVED BY: ESIMONSEN
	PROJECT NAME: INDEX			
	SCALE: NTS	SHEET NO: 1 OF 1	SIZE: A	TOLERANCES: ANGULAR ±1° LINEAR ±0.06

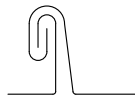
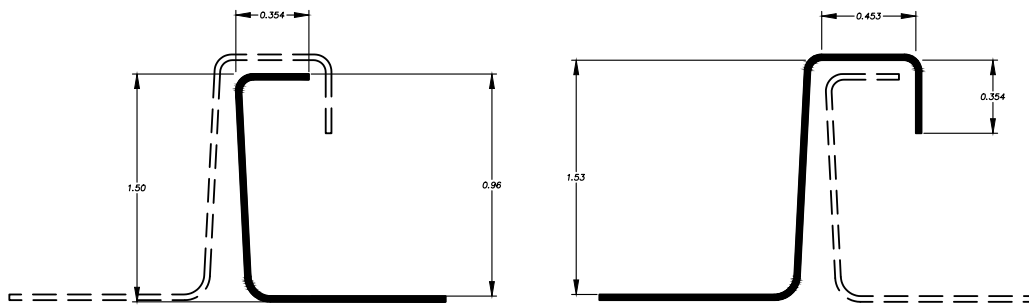
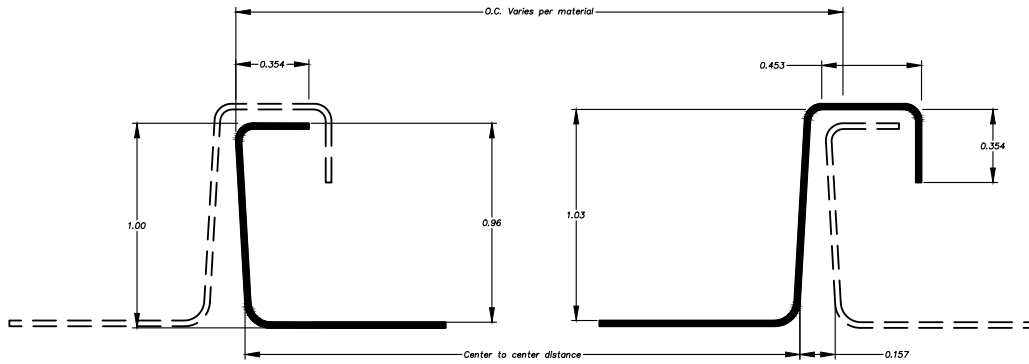

DOUBLE LOCK
STANDING SEAM
SLOPE > 3° (0.625:12)

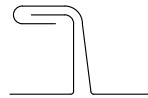

ANGLED
STANDING SEAM
SLOPE > 25° (6:12)
SLOPE > 35° (9:12)
IN AREAS OF HIGH SNOW

NOTE:

Information and details are only a baseline for system and installation. Modification to meet project requirement is the responsibility of the designer, architect and contractor. MetalTech-USA project staff are available to assist throughout the design and build process. © 2011 MetalTech-USA. All rights reserved.

	UNLESS OTHERWISE SPECIFIED DIMENSIONS ARE IN INCHES		DRAWING NAME: STANDING SEAM PANEL	REVISION NO: A	DATED CREATED: 1/23/2015
			DWG NO: MT_SSRP_1001	CHECKED BY: ESIMONSEN	APPROVED BY: ESIMONSEN
	PROJECT NAME: GENERAL DETAILS				
	SCALE: NTS	SHEET NO: 1 OF 19	SIZE: A	TOLERANCES: ANGULAR ±1° LINEAR ±0.06	

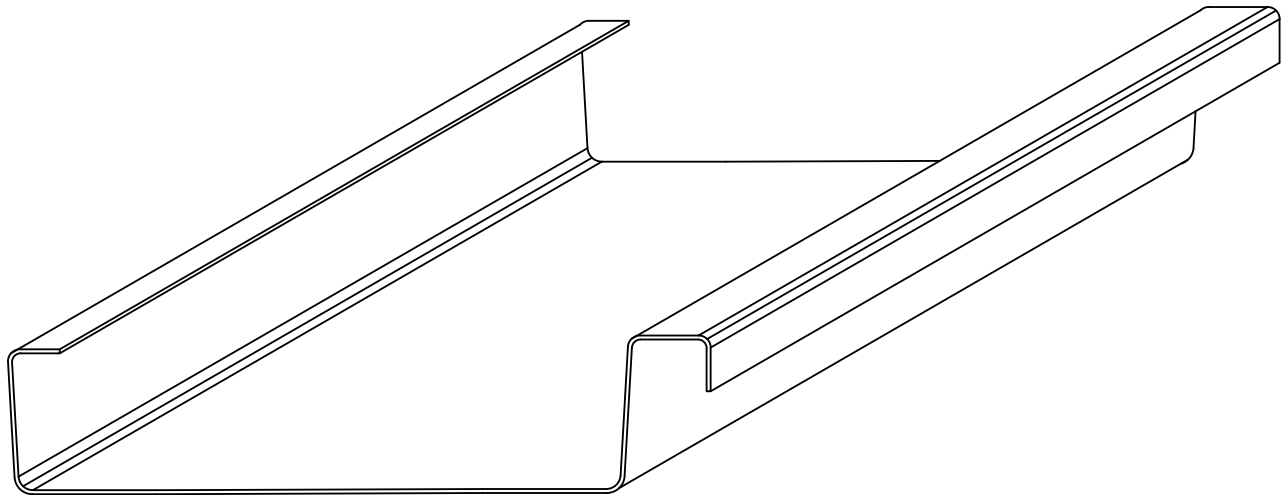

NOTE:
 Information and details are only a baseline for system and installation. Modification to meet project requirement is the responsibility of the designer, architect and contractor. MetalTech–USA project staff are available to assist throughout the design and build process. © 2011 MetalTech–USA. All rights reserved.

UNLESS OTHERWISE SPECIFIED DIMENSIONS ARE IN INCHES	DRAWING NAME: STANDING SEAM PANEL (ISOMETRIC)		REVISION NO: A	DATED CREATED: 1/23/2015
	DWG NO: MT_SSRP_1002		CHECKED BY: ESIMONSEN	APPROVED BY: ESIMONSEN
	PROJECT NAME: GENERAL DETAILS			
	SCALE: NTS	SHEET NO: 2 OF 19	SIZE: A	TOLERANCES: ANGULAR $\pm 1^\circ$ LINEAR ± 0.06

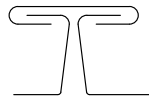
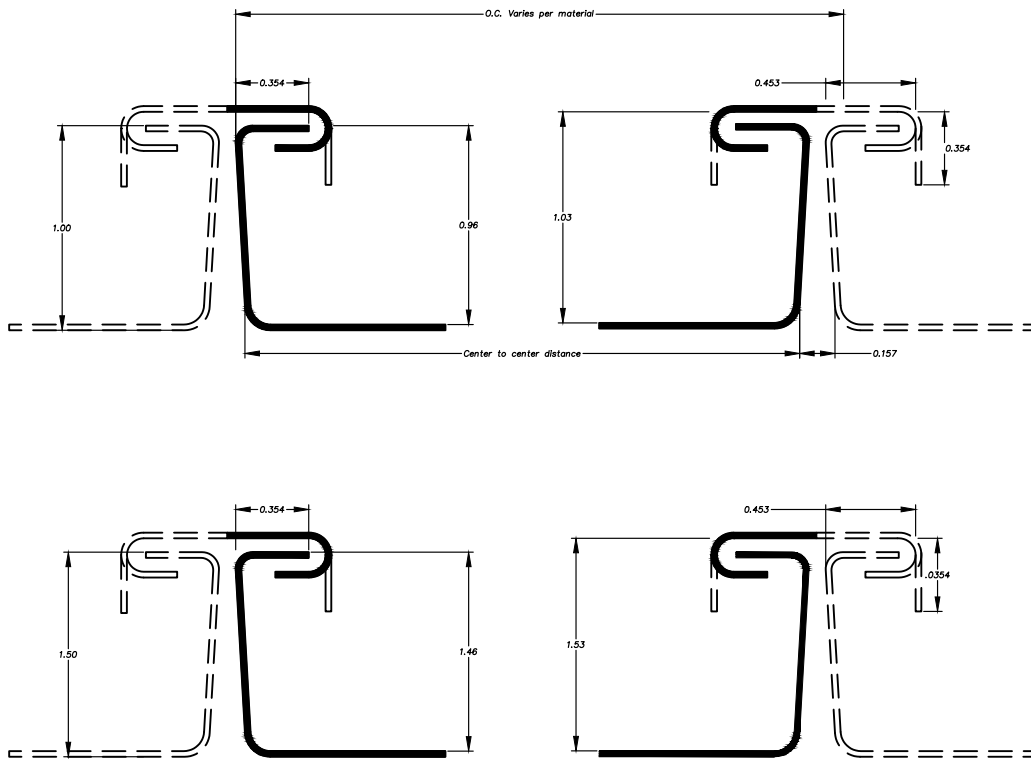

DOUBLE ANGLED
STANDING SEAM
SLOPE > 25° (6:12)

NOTE:

Information and details are only a baseline for system and installation. Modification to meet project requirement is the responsibility of the designer, architect and contractor. MetalTech-USA project staff are available to assist throughout the design and build process. © 2011 MetalTech-USA. All rights reserved.

UNLESS OTHERWISE SPECIFIED DIMENSIONS ARE IN INCHES	DRAWING NAME: STANDING SEAM PANEL (DASS)	REVISION NO: A	DATED CREATED: 1/23/2015
	DWG NO: MT_SSRP_1003	CHECKED BY: ESIMONSEN	APPROVED BY: ESIMONSEN
	PROJECT NAME: GENERAL DETAILS		
	SCALE: NTS	SHEET NO: 3 OF 19	SIZE: A

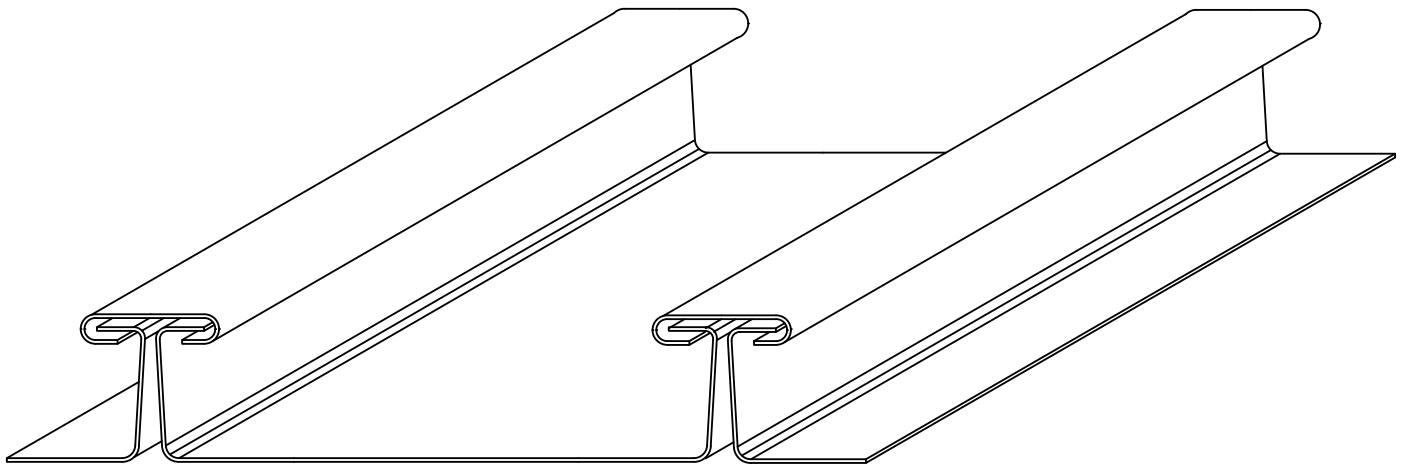

NOTE:
 Information and details are only a baseline for system and installation. Modification to meet project requirement is the responsibility of the designer, architect and contractor. MetalTech–USA project staff are available to assist throughout the design and build process. © 2011 MetalTech–USA. All rights reserved.

UNLESS OTHERWISE SPECIFIED DIMENSIONS ARE IN INCHES	DRAWING NAME: DASS PANEL (ISOMETRIC)	REVISION NO: A	DATED CREATED: 1/23/2015
	DWG NO: MT_SSRP_1004	CHECKED BY: ESIMONSEN	APPROVED BY: ESIMONSEN
	PROJECT NAME: GENERAL DETAILS		
	SCALE: NTS	SHEET NO: 4 OF 19	SIZE: A

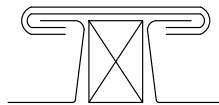
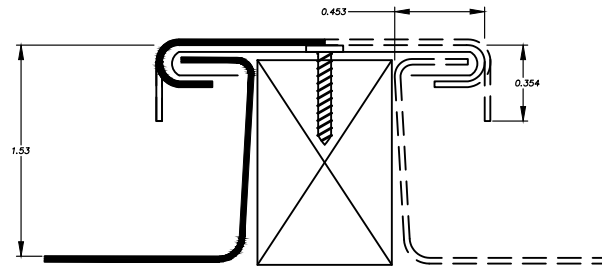
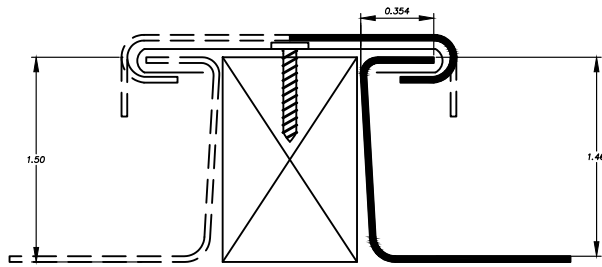
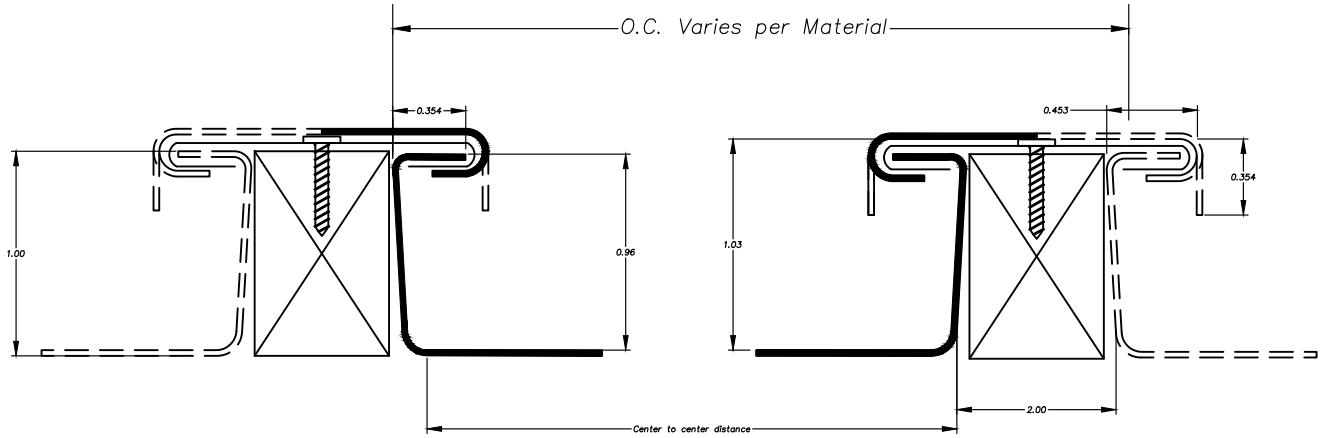

ROLL CAP STANDING SEAM
 2 INCH SEAM WIDTH
 Slope > 25° (6:12)

NOTE:

Information and details are only a baseline for system and installation. Modification to meet project requirement is the responsibility of the designer, architect and contractor. MetalTech-USA project staff are available to assist throughout the design and build process. © 2011 MetalTech-USA. All rights reserved.

 <p>METALTECH Global <small>a Forza Group Company</small> DESIGNING STRENGTH</p>	DRAWING NAME: STANDING SEAM PANEL (RCSS)		REVISION NO: A	DATED CREATED: 1/23/2015
	DWG NO: MT_SSRP_1005		CHECKED BY: ESIMONSEN	APPROVED BY: ESIMONSEN
	PROJECT NAME: GENERAL DETAILS			
	SCALE: NTS	SHEET NO: 5 OF 19	SIZE: A	TOLERANCES: ANGULAR $\pm 1^\circ$ LINEAR ± 0.06

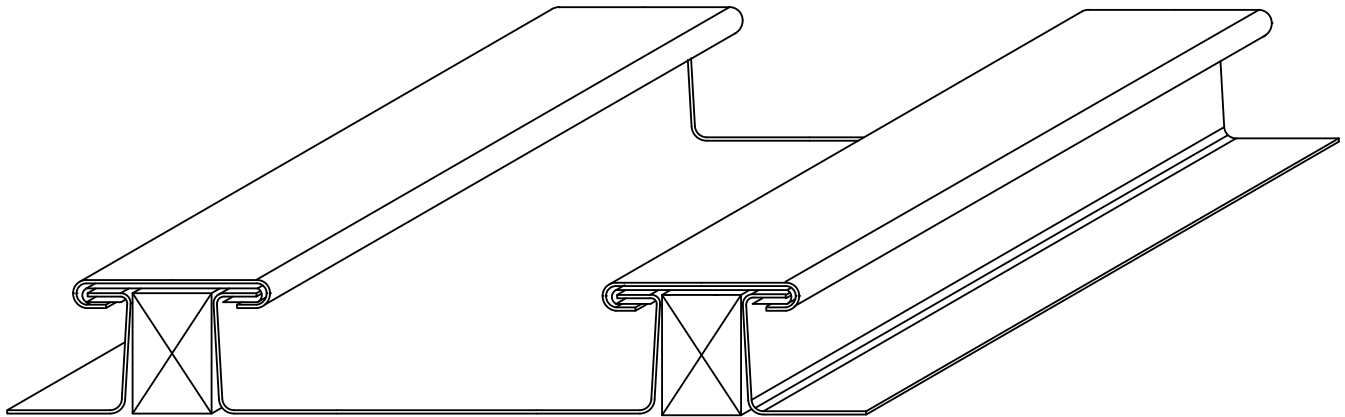

NOTE:
 Information and details are only a baseline for system and installation. Modification to meet project requirement is the responsibility of the designer, architect and contractor. MetalTech–USA project staff are available to assist throughout the design and build process. © 2011 MetalTech–USA. All rights reserved.

UNLESS OTHERWISE SPECIFIED DIMENSIONS ARE IN INCHES	DRAWING NAME: RCSS PANEL (ISOMETRIC)	REVISION NO: A	DATED CREATED: 1/23/2015
	DWG NO: MT_SSRP_1006	CHECKED BY: ESIMONSEN	APPROVED BY: ESIMONSEN
	PROJECT NAME: GENERAL DETAILS		
	SCALE: NTS	SHEET NO: 6 OF 19	SIZE: A

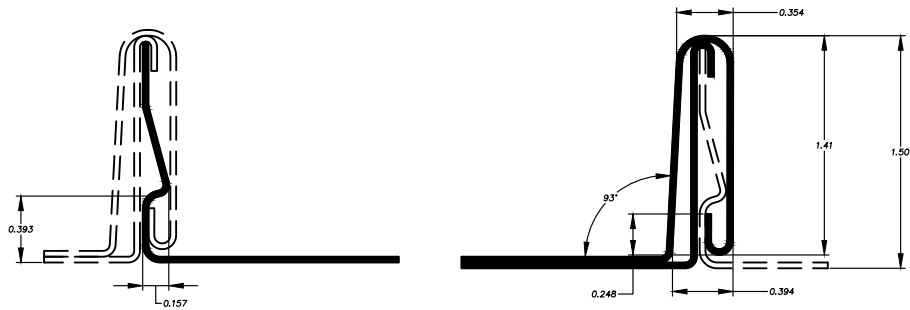
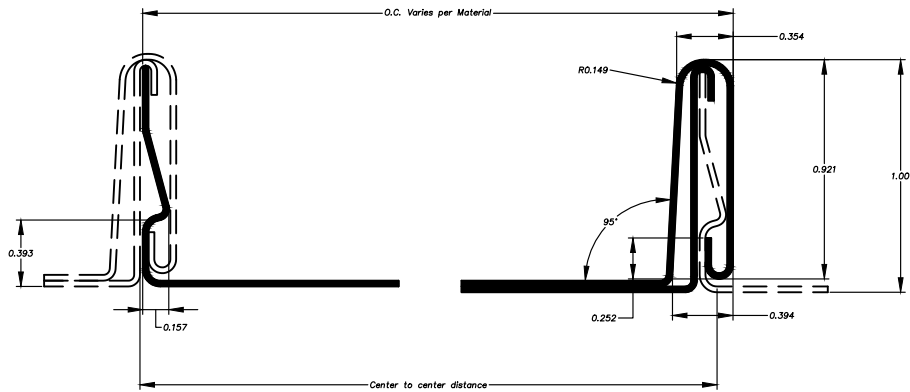

SNAP SEAM PROFILE
Slope > 25° (6:12)

NOTE:

Information and details are only a baseline for system and installation. Modification to meet project requirement is the responsibility of the designer, architect and contractor. MetalTech-USA project staff are available to assist throughout the design and build process. © 2011 MetalTech-USA. All rights reserved.

	UNLESS OTHERWISE SPECIFIED DIMENSIONS ARE IN INCHES		DRAWING NAME: SNAP SEAM PANEL	REVISION NO: A	DATED CREATED: 1/23/2015
			DWG NO: MT_SSRP_1007	CHECKED BY: ESIMONSEN	APPROVED BY: ESIMONSEN
		PROJECT NAME: GENERAL DETAILS			
		SCALE: NTS	SHEET NO: 7 OF 19	SIZE: A	TOLERANCES: ANGULAR ±1° LINEAR ±0.06

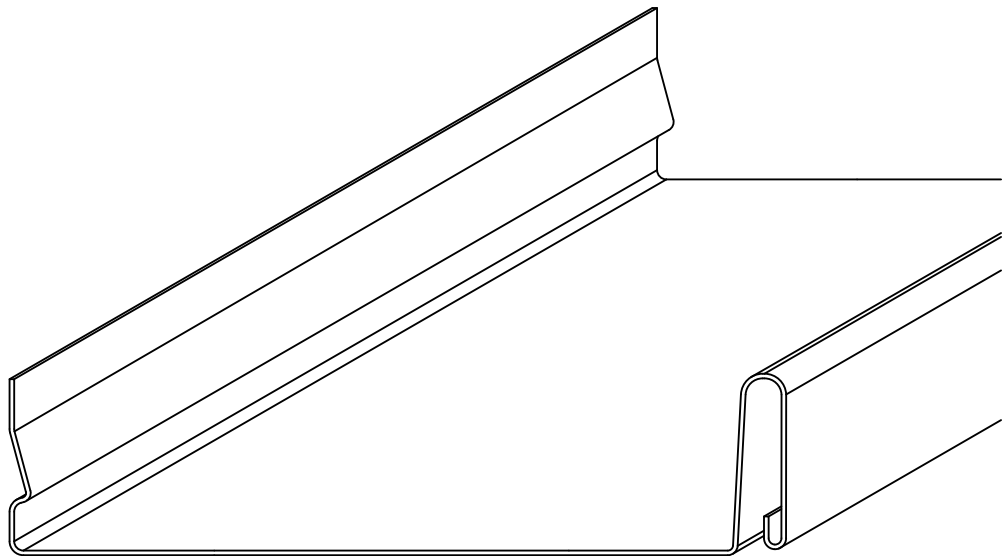

NOTE:

Information and details are only a baseline for system and installation. Modification to meet project requirement is the responsibility of the designer, architect and contractor. MetalTech-USA project staff are available to assist throughout the design and build process. © 2011 MetalTech-USA. All rights reserved.

UNLESS OTHERWISE SPECIFIED DIMENSIONS ARE IN INCHES	DRAWING NAME: SNAP SEAM PANEL (ISOMETRIC)		REVISION NO: A	DATED CREATED: 1/23/2015
	DWG NO: MT_SSRP_1008		CHECKED BY: ESIMONSEN	APPROVED BY: ESIMONSEN
	PROJECT NAME: GENERAL DETAILS			
	SCALE: NTS	SHEET NO: 8 OF 19	SIZE: A	TOLERANCES: ANGULAR ±1° LINEAR ±0.06

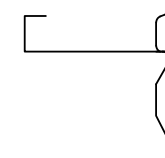
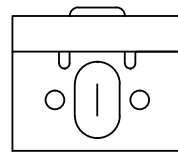
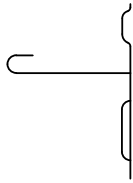
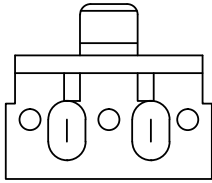
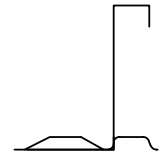
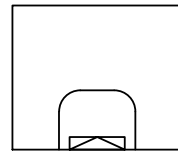
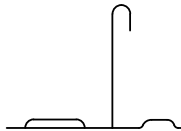
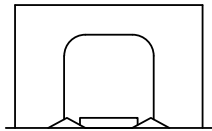

MT 150 SLR 22 G

MT 150FC 26S

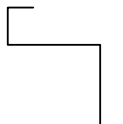
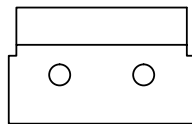
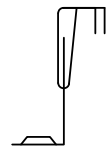
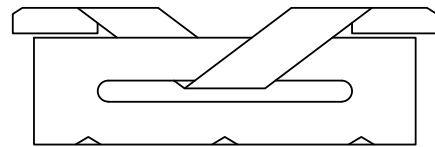
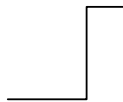

MT 150 B

MT 100 FC 26S

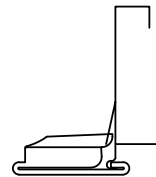
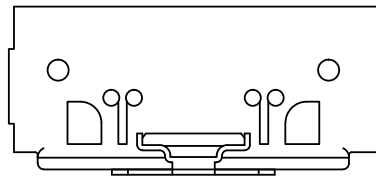

MT 150 F

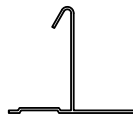
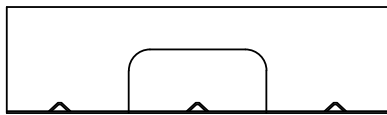

MT 100 SLQ 22 S

MT 150 SLR 22 G

NOTE: Clip type is determined by panel type and project specifications.

NOTE:

Information and details are only a baseline for system and installation. Modification to meet project requirement is the responsibility of the designer, architect and contractor. MetalTech-USA project staff are available to assist throughout the design and build process. © 2011 MetalTech-USA. All rights reserved.

UNLESS OTHERWISE SPECIFIED
DIMENSIONS ARE IN INCHES

DRAWING NAME:
STANDING SEAM CLIPS

REVISION NO:
A

DATED CREATED:
1/23/2015



DWG NO:
MT_SSRP_1009

CHECKED BY:
ESIMONSEN

APPROVED BY:
ESIMONSEN

PROJECT NAME:
GENERAL DETAILS

SCALE:
NTS

SHEET NO:
9 OF 19

SIZE:
A

TOLERANCES:
ANGULAR ±1° LINEAR ±0.06

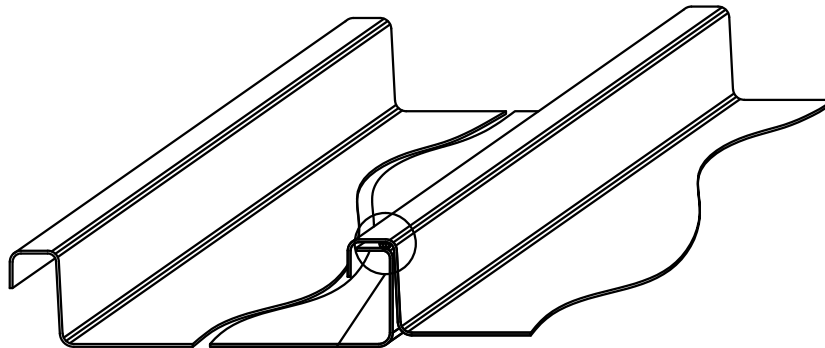

Standing Seam Profile
with factory applied seam
sealant at continuous
length of female seam
leg.

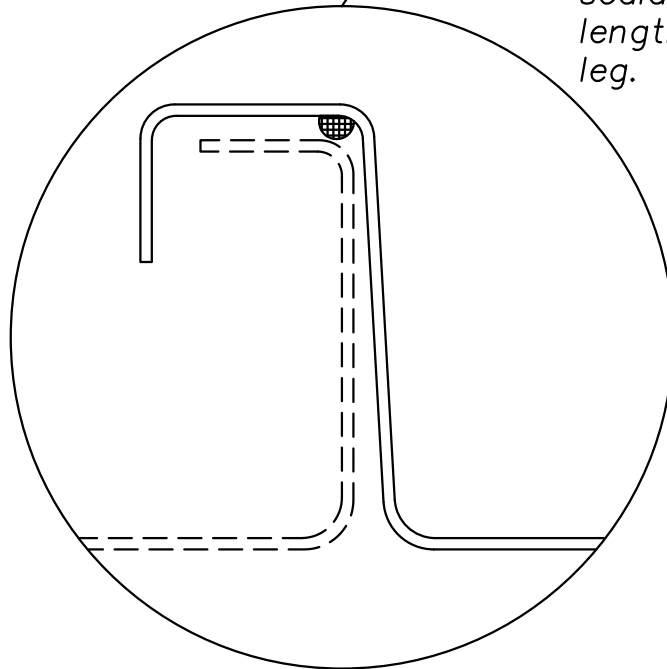

NOTE:

Information and details are only a baseline for system and installation. Modification to meet project requirement is the responsibility of the designer, architect and contractor. MetalTech-USA project staff are available to assist throughout the design and build process. © 2011 MetalTech-USA. All rights reserved.

UNLESS OTHERWISE SPECIFIED DIMENSIONS ARE IN INCHES	DRAWING NAME: SEAM SEALANT APPLICATION DETAIL	REVISION NO: A	DATED CREATED: 1/23/2015
	DWG NO: MT_SSRP_1010	CHECKED BY: ESIMONSEN	APPROVED BY: ESIMONSEN
	PROJECT NAME: GENERAL DETAILS		
	SCALE: NTS	SHEET NO: 10 OF 19	SIZE: A

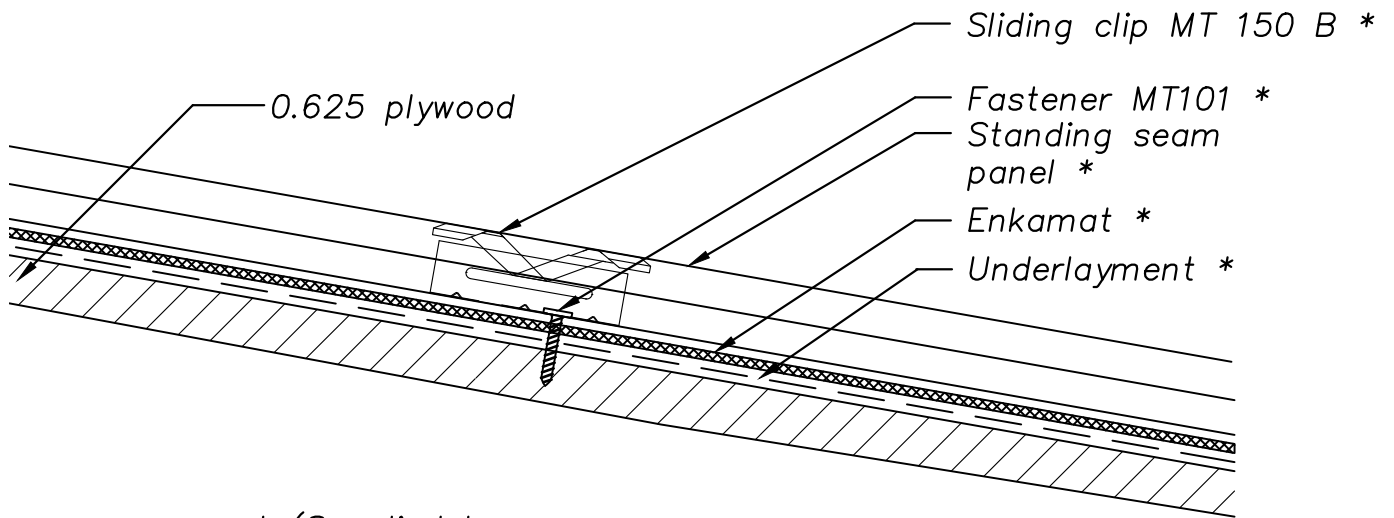

* (Supplied by
Metaltech-USA if
requested)

NOTE:

Information and details are only a baseline for system and installation. Modification to meet project requirement is the responsibility of the designer, architect and contractor. MetalTech-USA project staff are available to assist throughout the design and build process. © 2011 MetalTech-USA. All rights reserved.

	UNLESS OTHERWISE SPECIFIED DIMENSIONS ARE IN INCHES		DRAWING NAME: SS PANEL SECTION – SLIDING CLIP	REVISION NO: A	DATED CREATED: 1/23/2015
			DWG NO: MT_SSRP_1011	CHECKED BY: ESIMONSEN	APPROVED BY: ESIMONSEN
	PROJECT NAME: GENERAL DETAILS				
	SCALE: NTS	SHEET NO: 11 OF 19	SIZE: A	TOLERANCES: ANGULAR $\pm 1^\circ$ LINEAR ± 0.06	

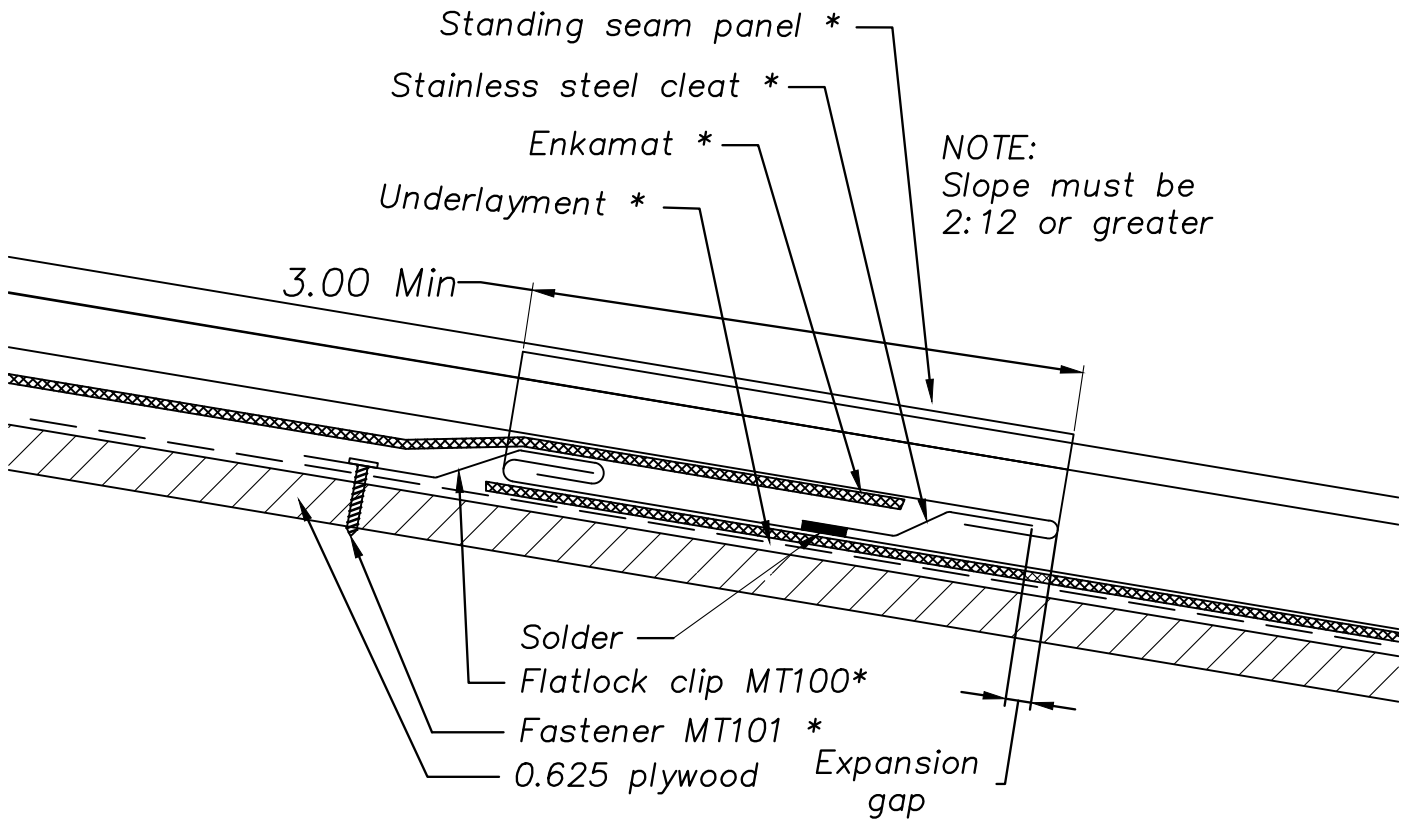

* (Supplied by
Metaltech-USA if
requested)

NOTE:

Information and details are only a baseline for system and installation. Modification to meet project requirement is the responsibility of the designer, architect and contractor. MetalTech-USA project staff are available to assist throughout the design and build process. © 2011 MetalTech-USA. All rights reserved.

<p>UNLESS OTHERWISE SPECIFIED DIMENSIONS ARE IN INCHES</p>	<p>DRAWING NAME: SS PANEL – DOUBLE WELT TRANSVERSE</p>		<p>REVISION NO: A</p>	<p>DATED CREATED: 1/23/2015</p>
	<p>DWG NO: MT_SSRP_1012</p>		<p>CHECKED BY: ESIMONSEN</p>	<p>APPROVED BY: ESIMONSEN</p>
<p>PROJECT NAME: GENERAL DETAILS</p>				
<p>SCALE: NTS</p>	<p>SHEET NO: 12 OF 19</p>	<p>SIZE: A</p>	<p>TOLERANCES: ANGULAR ±1° LINEAR ±0.06</p>	



NOTE:
Slope must be
8:12 or greater

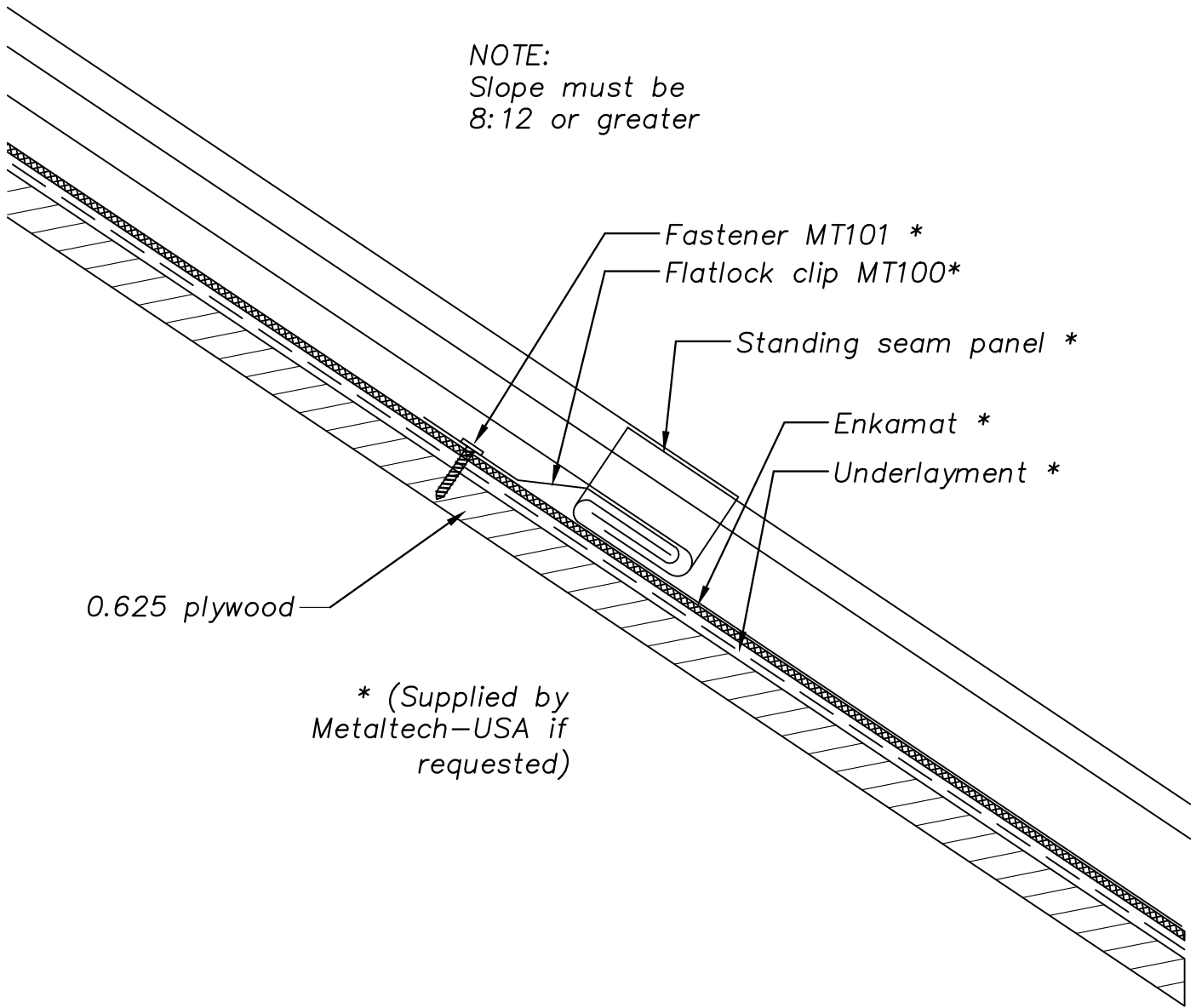

* (Supplied by
Metaltech-USA if
requested)

NOTE:
Information and details are only a baseline for system and installation. Modification to meet project requirement is the responsibility of the designer, architect and contractor. MetalTech-USA project staff are available to assist throughout the design and build process. © 2011 MetalTech-USA. All rights reserved.

<p>UNLESS OTHERWISE SPECIFIED DIMENSIONS ARE IN INCHES</p>	<p>DRAWING NAME: SS PANEL – SINGLE WELT TRANSVERSE</p>		<p>REVISION NO: A</p>	<p>DATED CREATED: 1/23/2015</p>
	<p>DWG NO: MT_SSRP_1013</p>		<p>CHECKED BY: ESIMONSEN</p>	<p>APPROVED BY: ESIMONSEN</p>
<p>PROJECT NAME: GENERAL DETAILS</p>				
<p>SCALE: NTS</p>		<p>SHEET NO: 13 OF 19</p>	<p>SIZE: A</p>	<p>TOLERANCES: ANGULAR ±1° LINEAR ±0.06</p>



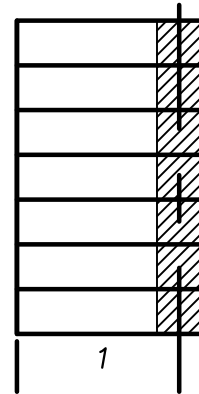
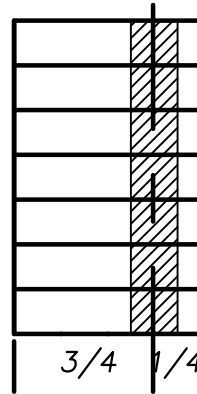
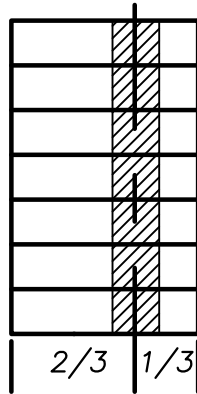
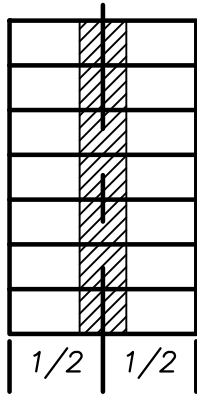
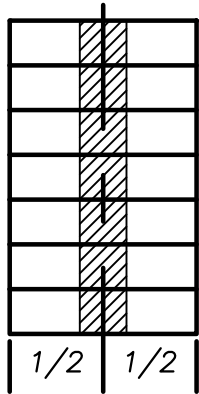

CURVED
(See dwg no. MT_SSRP_1015)



1:12
5°
(See dwg no. MT_SSRP_1016)



1:12–2:12
5–10°
(See dwg no. MT_SSRP_1017)

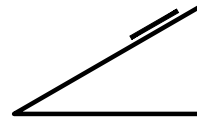

2:12–7:12
10–30°
(See dwg no. MT_SSRP_1018)

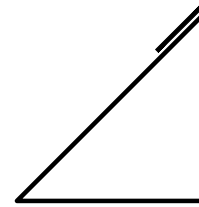

>7:12 or 30°
(See dwg no. MT_SSRP_1019)

Clip spacing depends on building height and panel width/material thickness.

Clip arrangement depends on pitch of roof.

Panel lengths 10' and less use fixed clips only.

Panel length greater than 10' use sliding clips and fixed clips.

NOTE:

Information and details are only a baseline for system and installation. Modification to meet project requirement is the responsibility of the designer, architect and contractor. MetalTech–USA project staff are available to assist throughout the design and build process. © 2011 MetalTech–USA. All rights reserved.

 <p>METALTECH Global a Forza Group Company DESIGNING STRENGTH</p>	<p>UNLESS OTHERWISE SPECIFIED DIMENSIONS ARE IN INCHES</p>		<p>DRAWING NAME: SS PANEL FIXING CLIP AREA</p>	<p>REVISION NO: A</p>	<p>DATED CREATED: 1/23/2015</p>
	<p>DWG NO: MT_SSRP_1014</p>		<p>CHECKED BY: ESIMONSEN</p>		<p>APPROVED BY: ESIMONSEN</p>
	<p>PROJECT NAME: GENERAL DETAILS</p>				
	<p>SCALE: NTS</p>	<p>SHEET NO: 14 OF 19</p>	<p>SIZE: A</p>	<p>TOLERANCES: ANGULAR ±1° LINEAR ±0.06</p>	

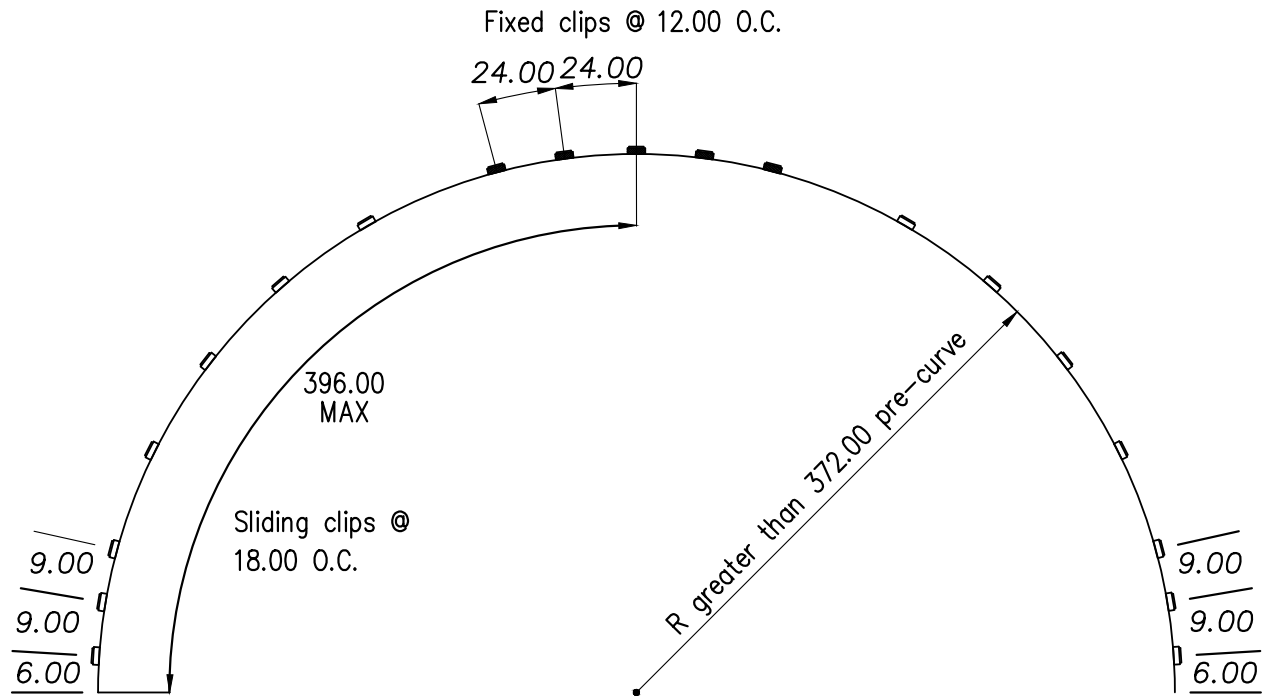

NOTE:
 240.00 maximum
 length for single lock
 standing seam for wall
 applications

Panels 96.00 or less
 req. fixing clips only

For a radius greater
 than 372.00 precurving
 is req.

Verify wind uplift
 requirements

Fixed clip - ■

Sliding clip - □

NOTE:

Information and details are only a baseline for system and installation. Modification to meet project requirement is the responsibility of the designer, architect and contractor. MetalTech-USA project staff are available to assist throughout the design and build process. © 2011 MetalTech-USA. All rights reserved.

 a Forza Group Company DESIGNING STRENGTH	UNLESS OTHERWISE SPECIFIED DIMENSIONS ARE IN INCHES		DRAWING NAME: SS PANEL CLIP LAYOUT ON RADIUS ROOF	REVISION NO: A	DATED CREATED: 1/23/2015
			DWG NO: MT_SSRP_1015	CHECKED BY: ESIMONSEN	APPROVED BY: ESIMONSEN
	PROJECT NAME: GENERAL DETAILS				
	SCALE: NTS	SHEET NO: 15 OF 19	SIZE: A	TOLERANCES: ANGULAR ±1° LINEAR ±0.06	

- Sliding clip
- Fixed clip
- ▨ Fixing clip area for:
1:12 or 5°

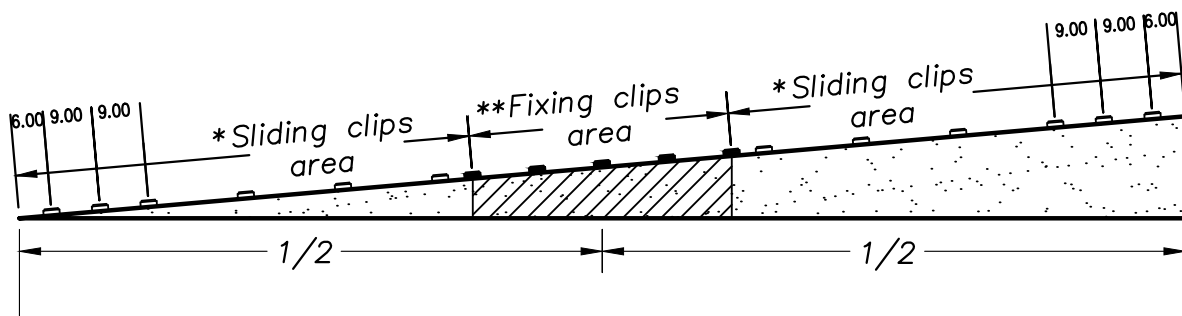

*Sliding clip spacing based on project specific performance requirements. Consult MT-USA sales for assistance with project engineering.

**Fixing clip area is $\frac{1}{3}$ the total panel length spacing based on project specific performance requirements.

NOTE:

Information and details are only a baseline for system and installation. Modification to meet project requirement is the responsibility of the designer, architect and contractor. MetalTech-USA project staff are available to assist throughout the design and build process. © 2011 MetalTech-USA. All rights reserved.

 <p>METALTECH Global a Forza Group Company DESIGNING STRENGTH</p>	DRAWING NAME: SS PANEL CLIP LAYOUT 1		REVISION NO: A	DATED CREATED: 1/23/2015
	DWG NO: MT_SSRP_1016		CHECKED BY: ESIMONSEN	APPROVED BY: ESIMONSEN
	PROJECT NAME: GENERAL DETAILS			
	SCALE: NTS	SHEET NO: 16 OF 19	SIZE: A	TOLERANCES: ANGULAR $\pm 1^\circ$ LINEAR ± 0.06

○ Sliding clip

■ Fixed clip

▨ Fixing clip area for:

1:12 - 2:12
5 - 10'

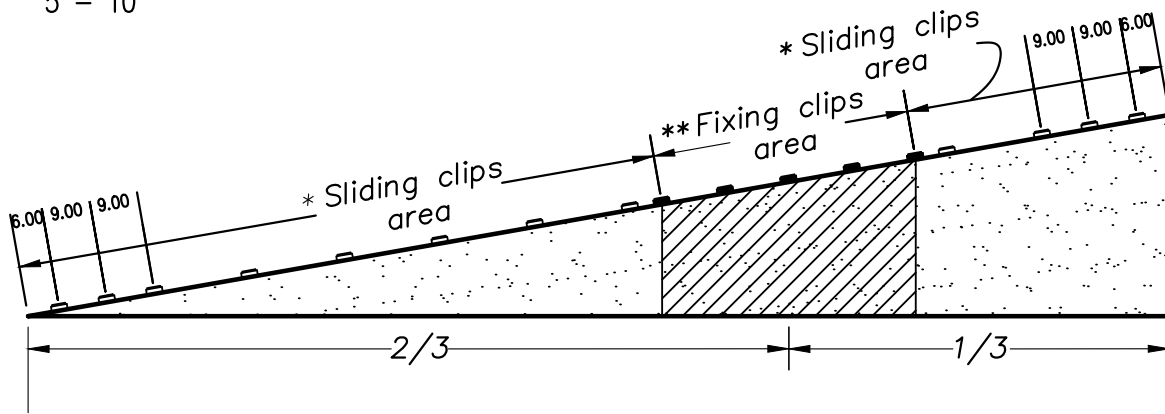

*Sliding clip spacing based on project specific performance requirements. Consult MT-USA sales for assistance with project engineering.

**Fixing clip area is $\frac{1}{3}$ the total panel length spacing based on project specific performance requirements.

NOTE:

Information and details are only a baseline for system and installation. Modification to meet project requirement is the responsibility of the designer, architect and contractor. MetalTech-USA project staff are available to assist throughout the design and build process. © 2011 MetalTech-USA. All rights reserved.

 <p>METALTECH Global a Forza Group Company DESIGNING STRENGTH</p>	<p>UNLESS OTHERWISE SPECIFIED DIMENSIONS ARE IN INCHES</p>		<p>DRAWING NAME: SS PANEL CLIP LAYOUT 2</p>	<p>REVISION NO: A</p>	<p>DATED CREATED: 1/23/2015</p>
	<p>DWG NO: MT_SSRP_1017</p>		<p>CHECKED BY: ESIMONSEN</p>		<p>APPROVED BY: ESIMONSEN</p>
	<p>PROJECT NAME: GENERAL DETAILS</p>				
	<p>SCALE: NTS</p>	<p>SHEET NO: 17 OF 19</p>	<p>SIZE: A</p>	<p>TOLERANCES: ANGULAR $\pm 1^\circ$ LINEAR ± 0.06</p>	

- Sliding clip
- Fixed clip
- ▨ Fixing clip area for:
2:12 – 7:12
10 – 30°

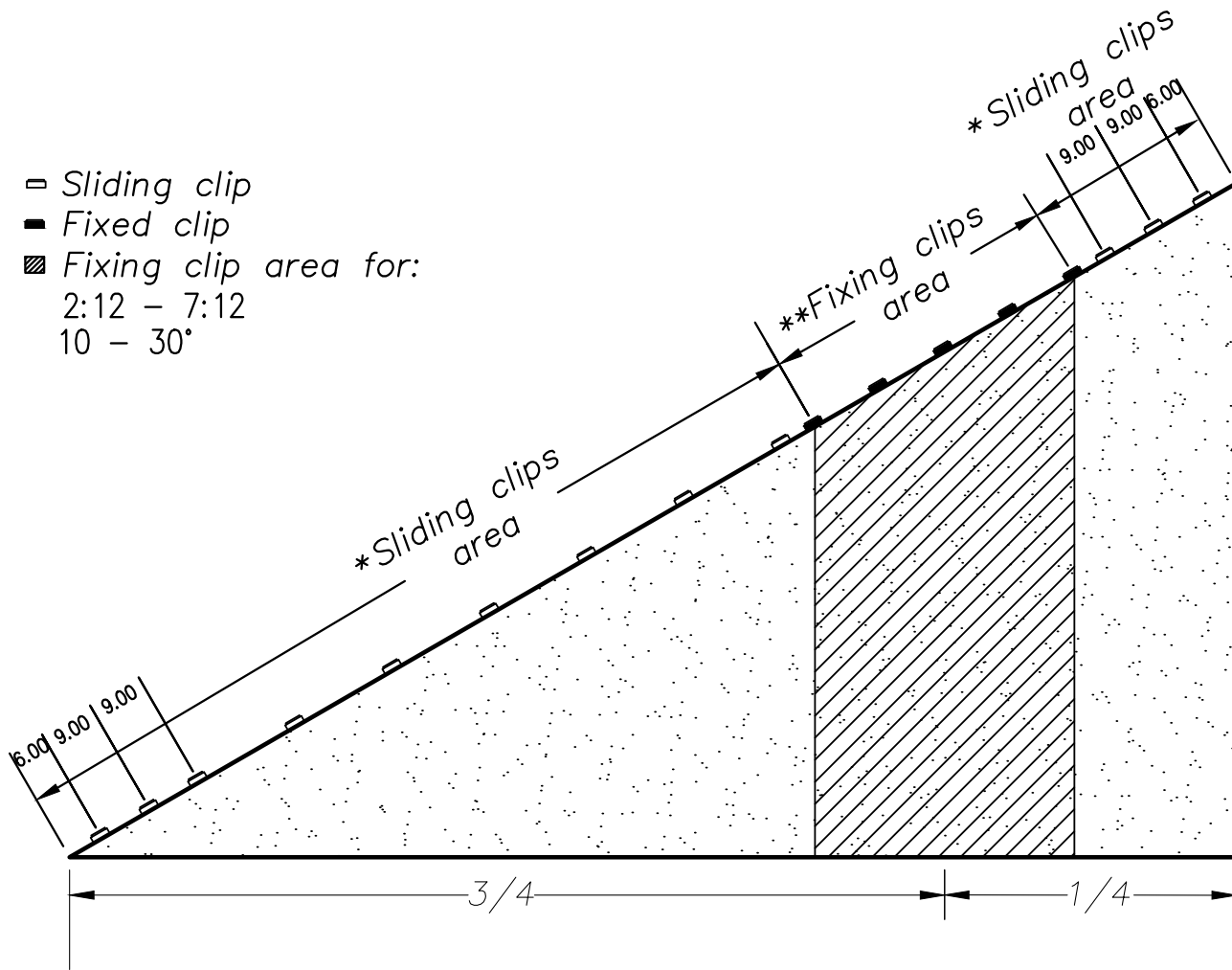

*Sliding clip spacing based on project specific performance requirements. Consult MT-USA sales for assistance with project engineering.

**Fixing clip area is $\frac{1}{8}$ the total panel length spacing based on project specific performance requirements.

NOTE:

Information and details are only a baseline for system and installation. Modification to meet project requirement is the responsibility of the designer, architect and contractor. MetalTech-USA project staff are available to assist throughout the design and build process. © 2011 MetalTech-USA. All rights reserved.

	UNLESS OTHERWISE SPECIFIED DIMENSIONS ARE IN INCHES		DRAWING NAME: SS PANEL CLIP LAYOUT 3	REVISION NO: A	DATED CREATED: 1/23/2015	
			DWG NO: MT_SSRP_1018	CHECKED BY: ESIMONSEN	APPROVED BY: ESIMONSEN	
			PROJECT NAME: GENERAL DETAILS			
	SCALE: NTS	SHEET NO: 18 OF 19	SIZE: A	TOLERANCES: ANGULAR $\pm 1^\circ$ LINEAR ± 0.06		

- Sliding clip
- Fixed clip
- ▨ Fixing clip area for:
Greater than 7:12 or 30 degrees

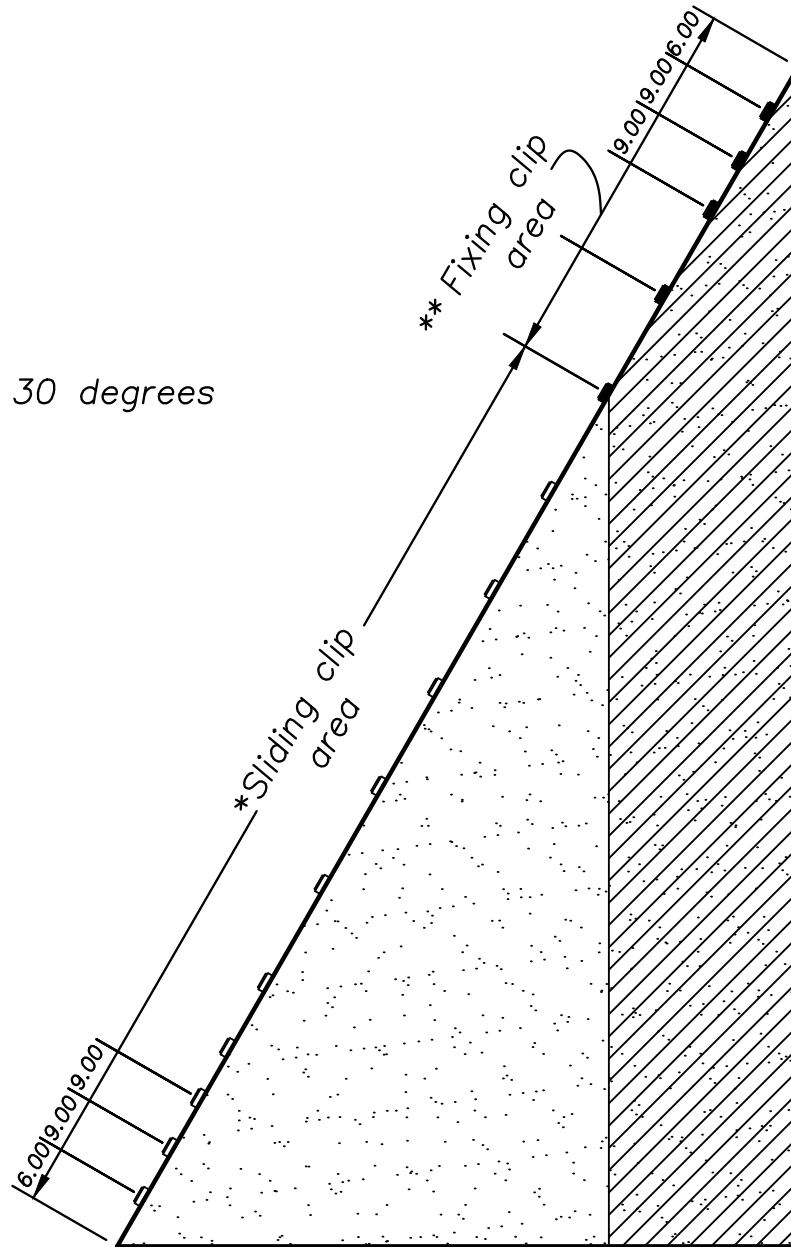

*Sliding clip spacing based on project specific performance requirements. Consult MT-USA sales for assistance with project engineering.

**Fixing clip area is $\frac{1}{3}$ the total panel length spacing based on project specific performance requirements.

NOTE:

Information and details are only a baseline for system and installation. Modification to meet project requirement is the responsibility of the designer, architect and contractor. MetalTech-USA project staff are available to assist throughout the design and build process. © 2011 MetalTech-USA. All rights reserved.

UNLESS OTHERWISE SPECIFIED DIMENSIONS ARE IN INCHES	DRAWING NAME: SS PANEL CLIP LAYOUT 4		REVISION NO: A	DATED CREATED: 1/23/2015
	DWG NO: MT_SSRP_1019		CHECKED BY: ESIMONSEN	APPROVED BY: ESIMONSEN
PROJECT NAME: GENERAL DETAILS				
SCALE: NTS		SHEET NO: 19 OF 19	SIZE: A	TOLERANCES: ANGULAR $\pm 1^\circ$ LINEAR ± 0.06



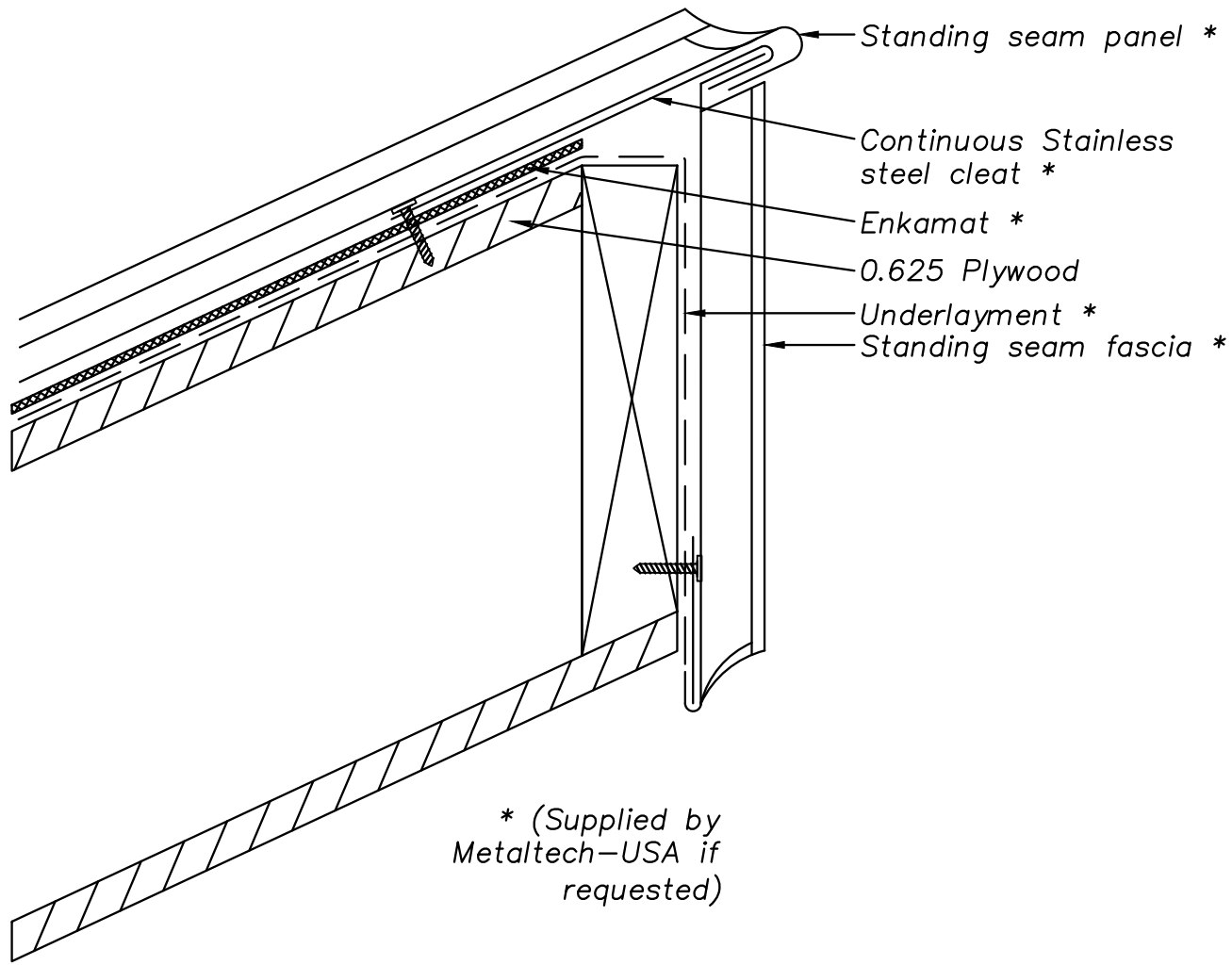

NOTE: Information and details are only a baseline for system and installation. Modification to meet project requirement is the responsibility of the designer, architect and contractor. MetalTech-USA project staff are available to assist throughout the design and build process. © 2011 MetalTech-USA. All rights reserved.

UNLESS OTHERWISE SPECIFIED DIMENSIONS ARE IN INCHES	DRAWING NAME: MONO PITCH RIDGE – OPTION 1		REVISION NO: A	DATED CREATED: 4/9/2015
	DWG NO: MT_SSRP_1101		CHECKED BY: ESIMONSEN	APPROVED BY: ESIMONSEN
PROJECT NAME: RIDGE DETAILS				
SCALE: NTS		SHEET NO: 1 OF 15	SIZE: A	TOLERANCES: ANGULAR ±1° LINEAR ±0.06



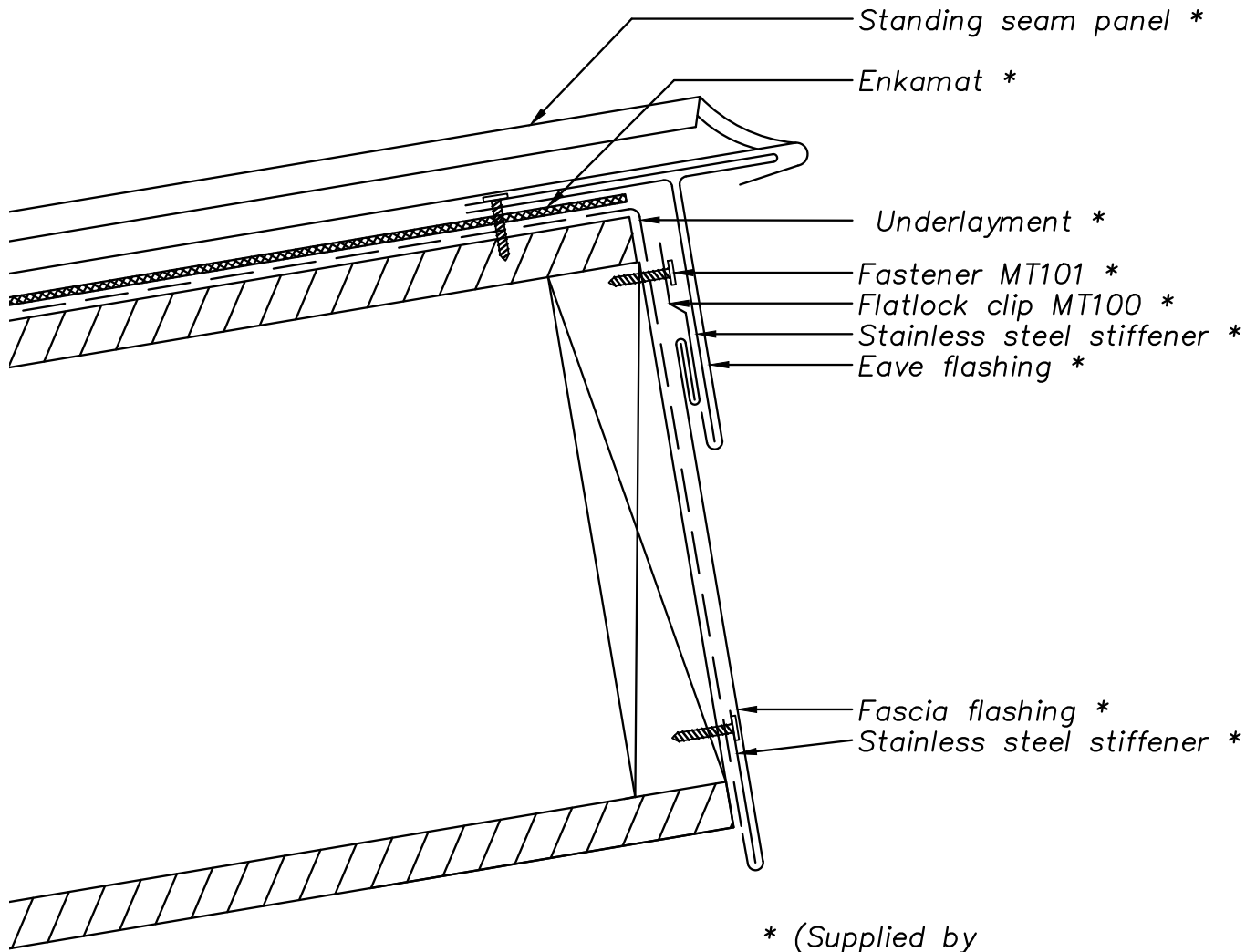

* (Supplied by Metaltech-USA if requested)

NOTE:

Information and details are only a baseline for system and installation. Modification to meet project requirement is the responsibility of the designer, architect and contractor. MetalTech-USA project staff are available to assist throughout the design and build process. © 2011 MetalTech-USA. All rights reserved.

UNLESS OTHERWISE SPECIFIED DIMENSIONS ARE IN INCHES	DRAWING NAME: MONO PITCH RIDGE – OPTION 2		REVISION NO: A	DATED CREATED: 4/9/2015
	DWG NO: MT_SSRP_1102		CHECKED BY: ESIMONSEN	APPROVED BY: ESIMONSEN
	PROJECT NAME: RIDGE DETAILS			
	SCALE: NTS	SHEET NO: 2 OF 15	SIZE: A	TOLERANCES: ANGULAR ±1° LINEAR ±0.06

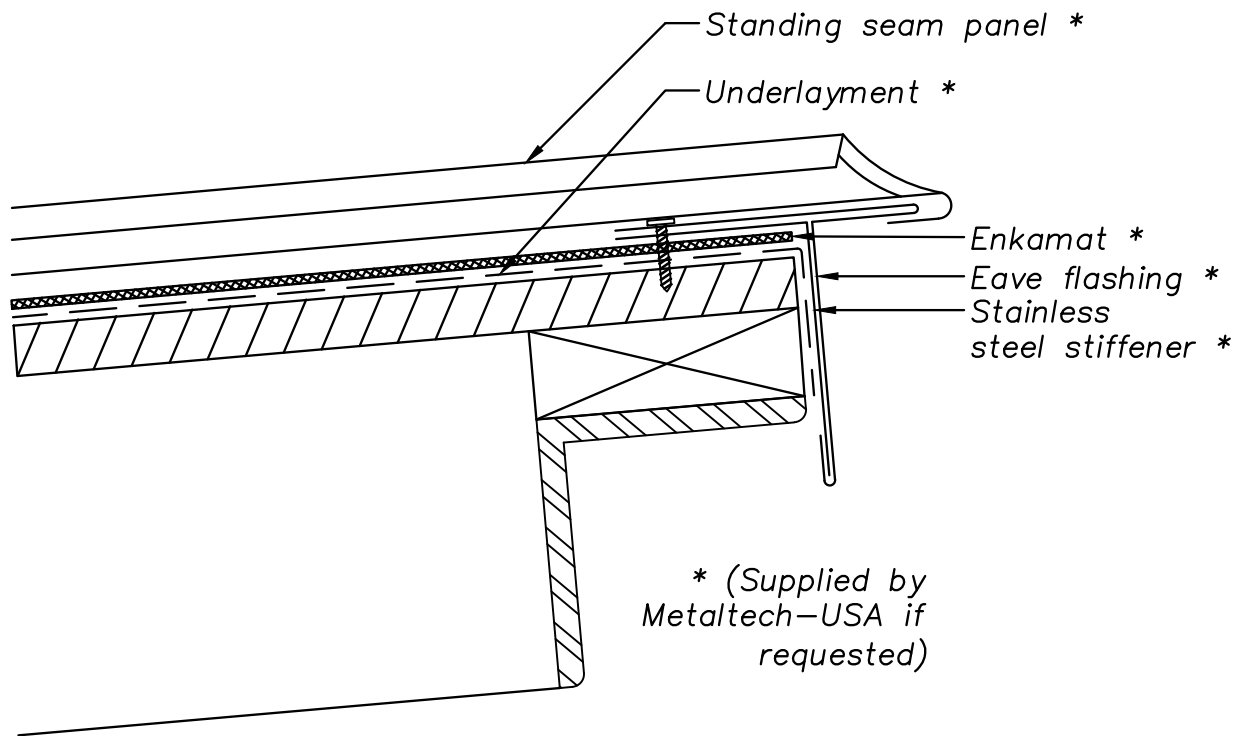

NOTE:
 Information and details are only a baseline for system and installation. Modification to meet project requirement is the responsibility of the designer, architect and contractor. MetalTech-USA project staff are available to assist throughout the design and build process. © 2011 MetalTech-USA. All rights reserved.

	DRAWING NAME: MONO PITCH RIDGE – OPTION 3		REVISION NO: A	DATED CREATED: 4/9/2015
	DWG NO: MT_SSRP_1103		CHECKED BY: ESIMONSEN	APPROVED BY: ESIMONSEN
	PROJECT NAME: RIDGE DETAILS			
	SCALE: NTS	SHEET NO: 3 OF 15	SIZE: A	TOLERANCES: ANGULAR $\pm 1^\circ$ LINEAR ± 0.06

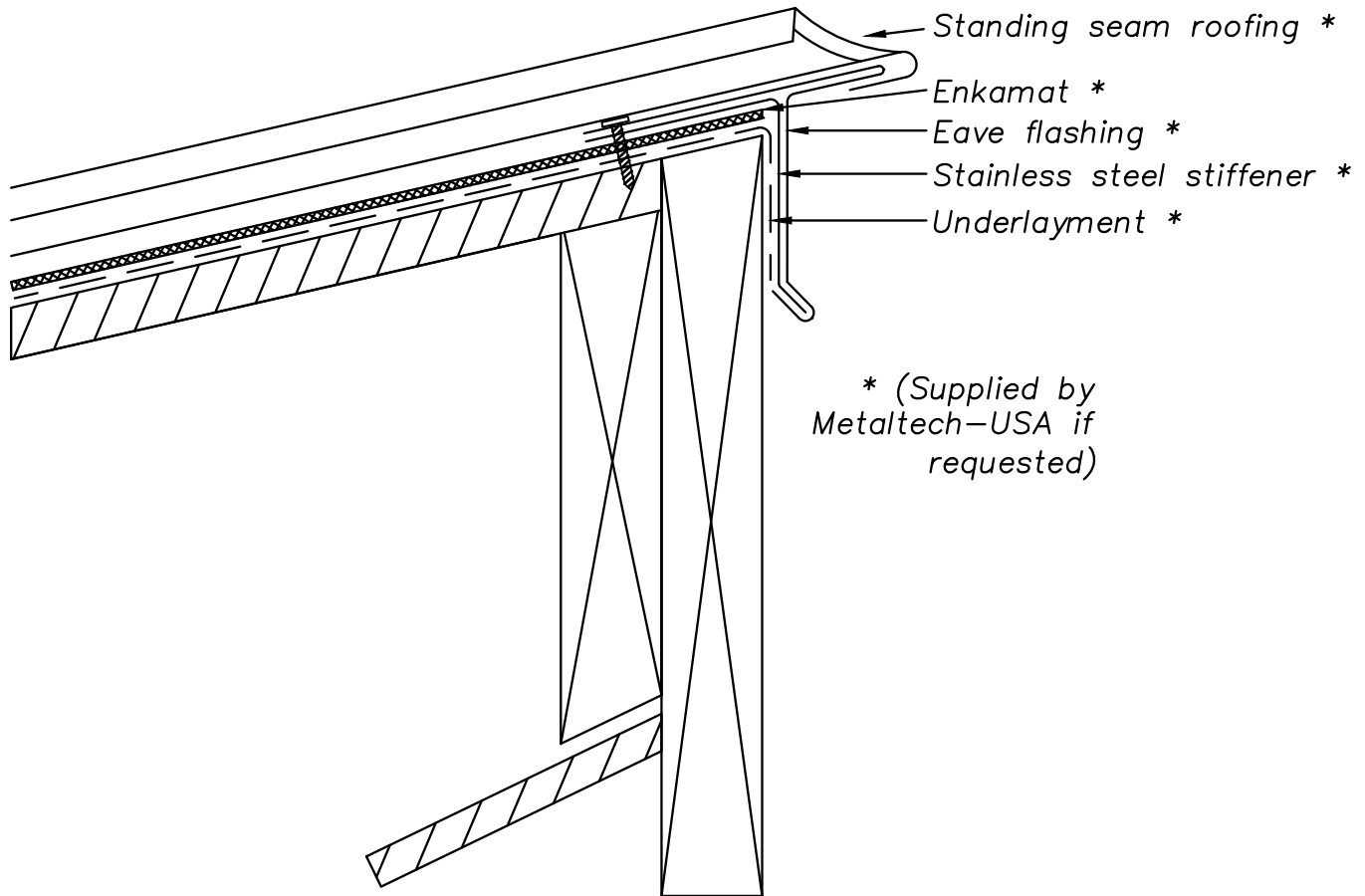

NOTE:
 Information and details are only a baseline for system and installation. Modification to meet project requirement is the responsibility of the designer, architect and contractor. MetalTech-USA project staff are available to assist throughout the design and build process. © 2011 MetalTech-USA. All rights reserved.

	DRAWING NAME: MONO PITCH RIDGE – OPTION 4		REVISION NO: A	DATED CREATED: 4/9/2015
	DWG NO: MT_SSRP_1104		CHECKED BY: ESIMONSEN	APPROVED BY: ESIMONSEN
	PROJECT NAME: RIDGE DETAILS			
	SCALE: NTS	SHEET NO: 4 OF 15	SIZE: A	TOLERANCES: ANGULAR $\pm 1^\circ$ LINEAR ± 0.06

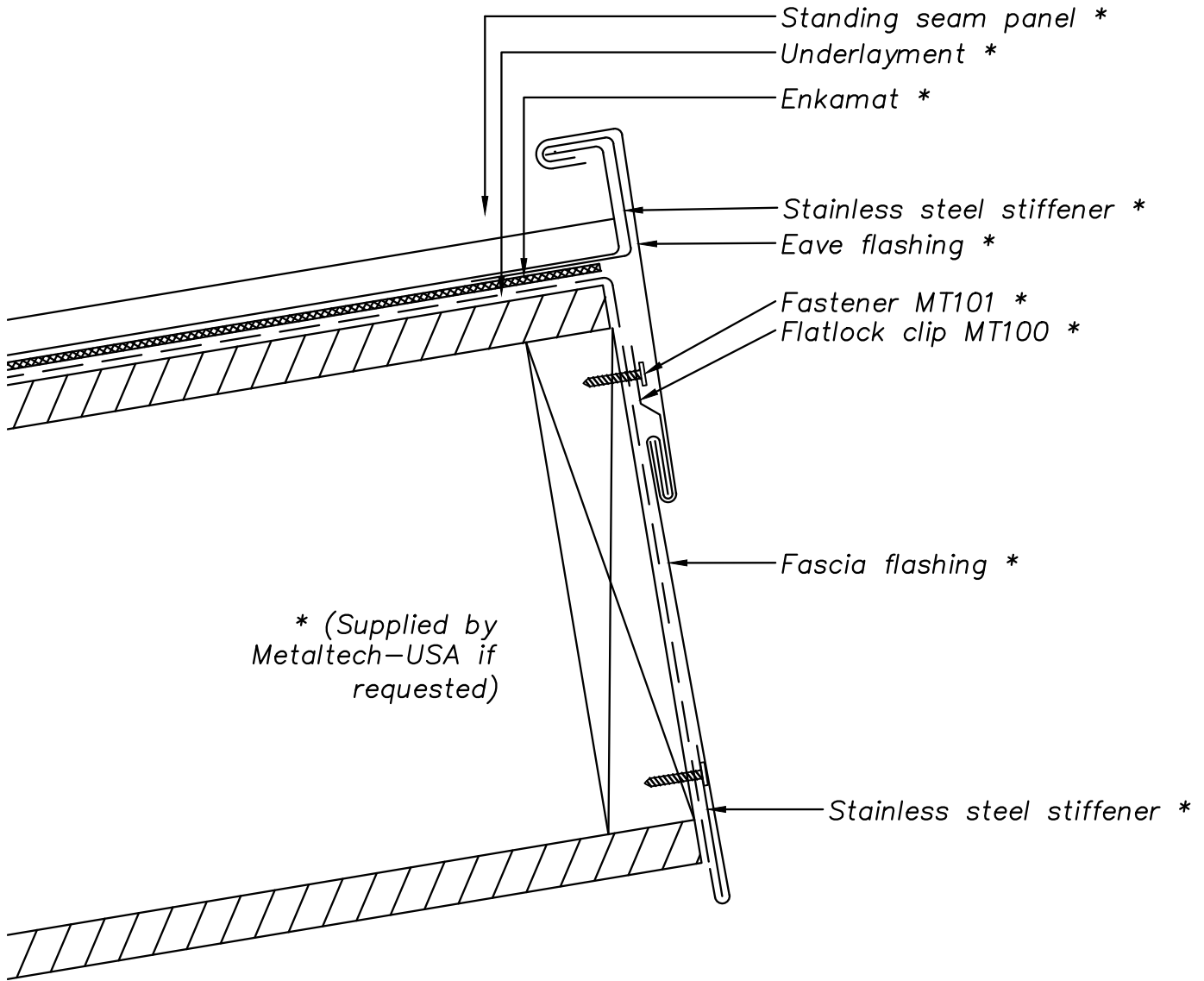

NOTE:
 Information and details are only a baseline for system and installation. Modification to meet project requirement is the responsibility of the designer, architect and contractor. MetalTech-USA project staff are available to assist throughout the design and build process. © 2011 MetalTech-USA. All rights reserved.

UNLESS OTHERWISE SPECIFIED DIMENSIONS ARE IN INCHES	DRAWING NAME: MONO PITCH RIDGE – OPTION 5	REVISION NO: A	DATED CREATED: 4/9/2015
	DWG NO: MT_SSRP_1105	CHECKED BY: ESIMONSEN	APPROVED BY: ESIMONSEN
	PROJECT NAME: RIDGE DETAILS		
	SCALE: NTS	SHEET NO: 5 OF 15	SIZE: A

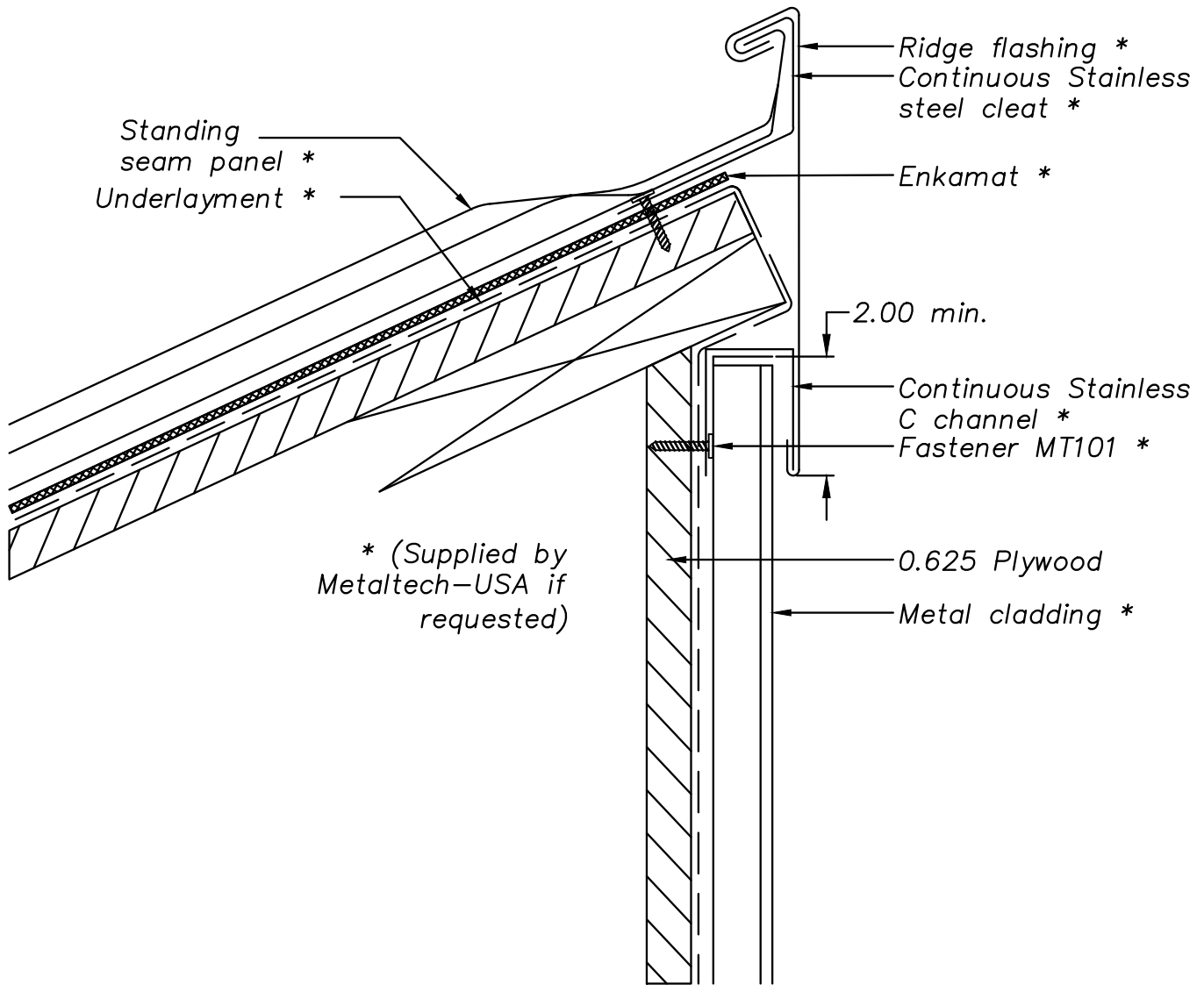

NOTE: Information and details are only a baseline for system and installation. Modification to meet project requirement is the responsibility of the designer, architect and contractor. MetalTech-USA project staff are available to assist throughout the design and build process. © 2011 MetalTech-USA. All rights reserved.

UNLESS OTHERWISE SPECIFIED DIMENSIONS ARE IN INCHES	DRAWING NAME: MONO PITCH RIDGE – OPTION 6		REVISION NO: A	DATED CREATED: 4/9/2015
	DWG NO: MT_SSRP_1106		CHECKED BY: ESIMONSEN	APPROVED BY: ESIMONSEN
				
PROJECT NAME: RIDGE DETAILS				
SCALE: NTS	SHEET NO: 6 OF 15	SIZE: A	TOLERANCES: ANGULAR $\pm 1^\circ$ LINEAR ± 0.06	

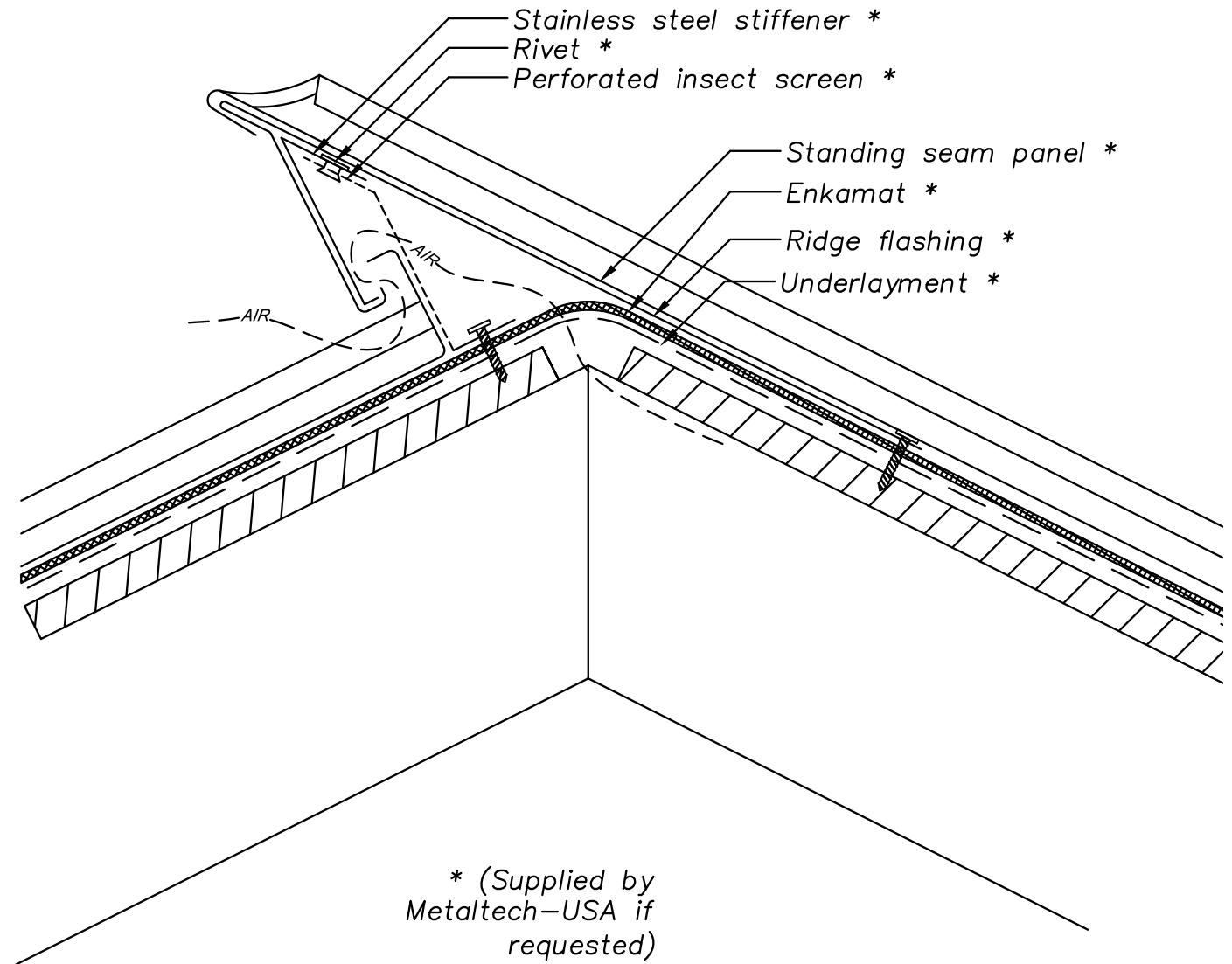

NOTE:
 Information and details are only a baseline for system and installation. Modification to meet project requirement is the responsibility of the designer, architect and contractor. MetalTech-USA project staff are available to assist throughout the design and build process. © 2011 MetalTech-USA. All rights reserved.

UNLESS OTHERWISE SPECIFIED DIMENSIONS ARE IN INCHES	DRAWING NAME: RIDGE W/ OFFSET SLOPE		REVISION NO: A	DATED CREATED: 4/9/2015
	DWG NO: MT_SSRP_1107		CHECKED BY: ESIMONSEN	APPROVED BY: ESIMONSEN
				
PROJECT NAME: RIDGE DETAILS				
SCALE: NTS	SHEET NO: 7 OF 15	SIZE: A	TOLERANCES: ANGULAR $\pm 1^\circ$ LINEAR ± 0.06	

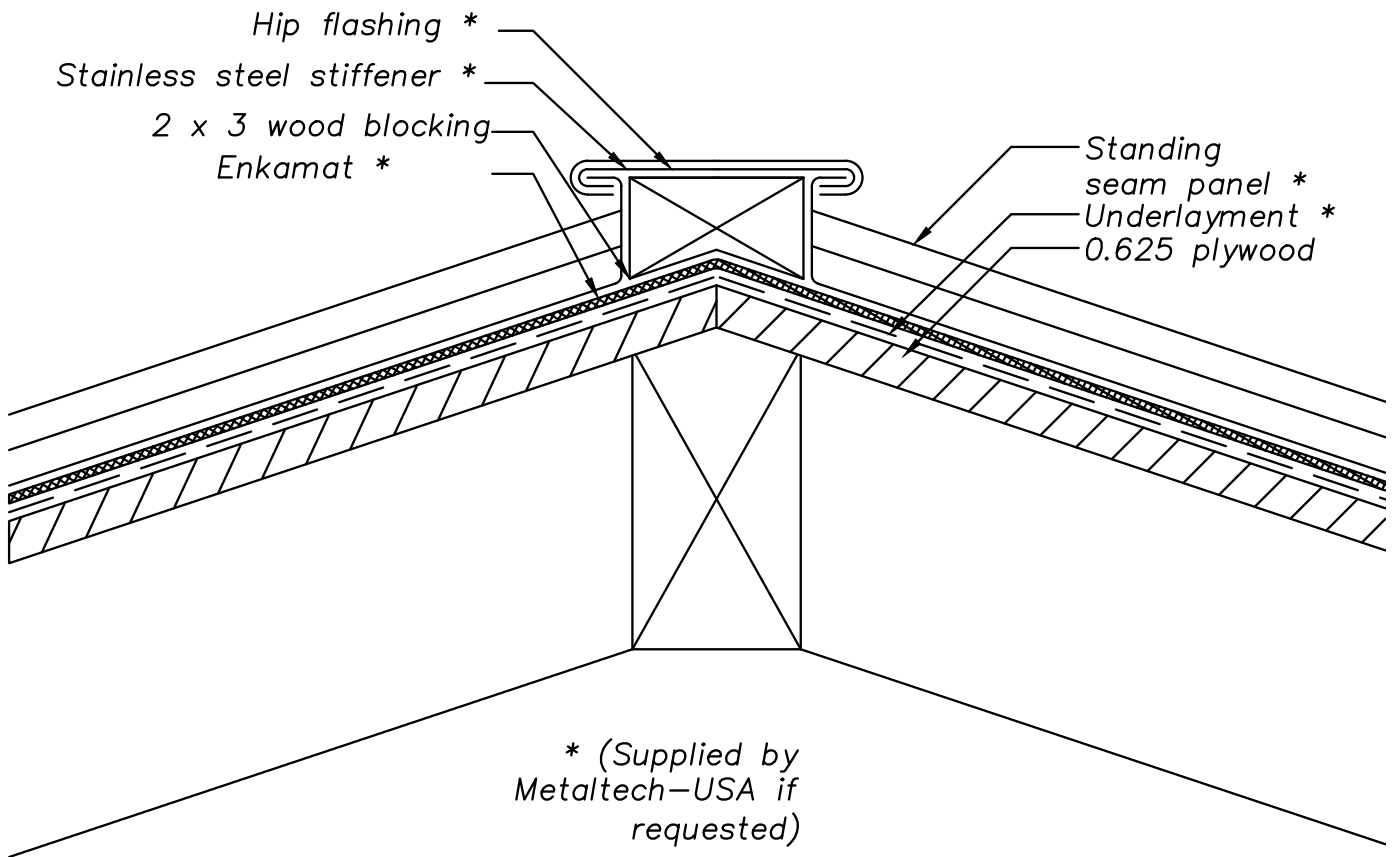

NOTE:
 Information and details are only a baseline for system and installation. Modification to meet project requirement is the responsibility of the designer, architect and contractor. MetalTech-USA project staff are available to assist throughout the design and build process. © 2011 MetalTech-USA. All rights reserved.

UNLESS OTHERWISE SPECIFIED DIMENSIONS ARE IN INCHES	DRAWING NAME: HIP/RIDGE DETAIL- OPTION 1		REVISION NO: A	DATED CREATED: 4/9/2015
	DWG NO: MT_SSRP_1108		CHECKED BY: ESIMONSEN	APPROVED BY: ESIMONSEN
	PROJECT NAME: RIDGE DETAILS			
	SCALE: NTS	SHEET NO: 8 OF 15	SIZE: A	TOLERANCES: ANGULAR ±1° LINEAR ±0.06

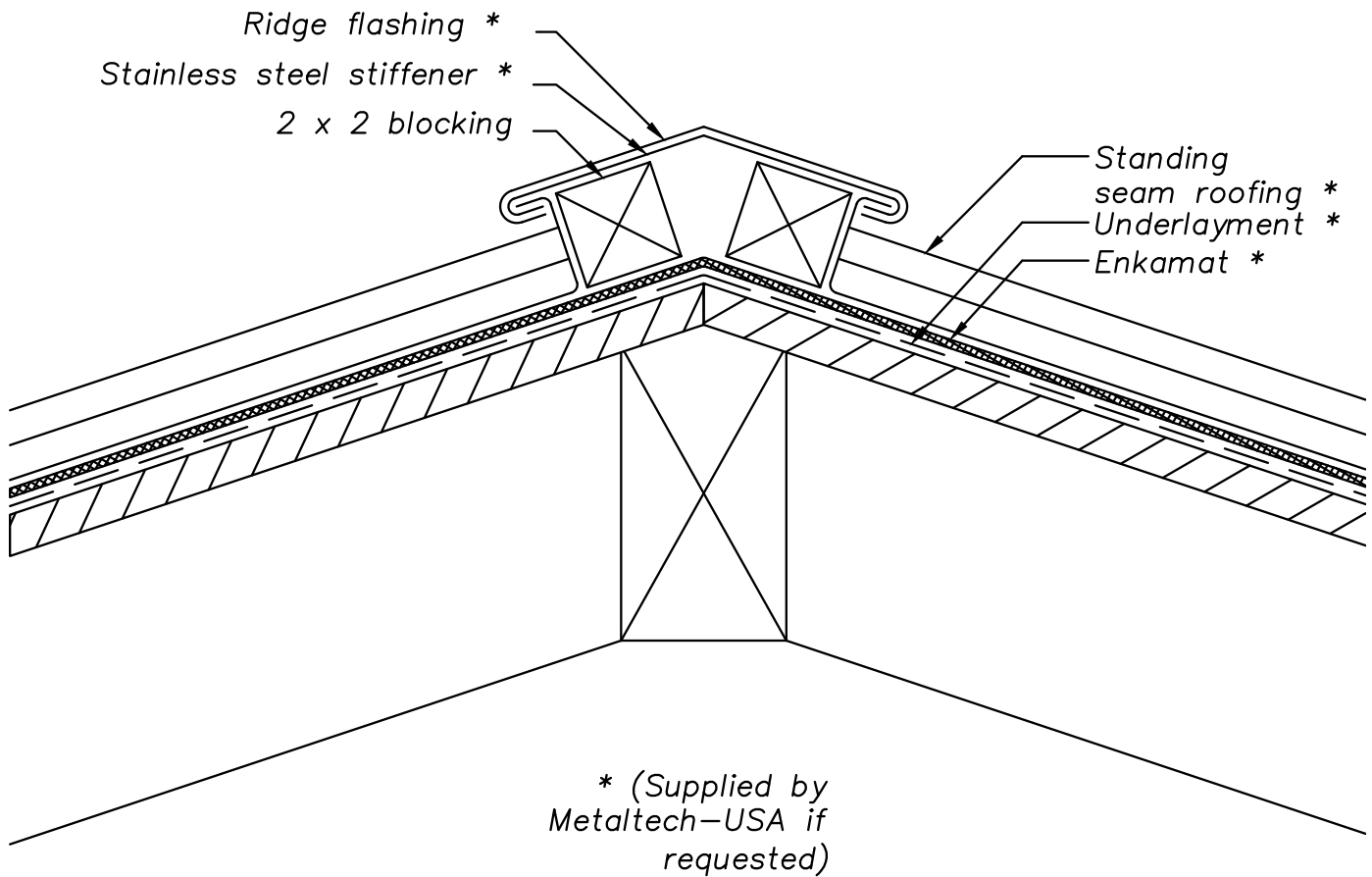

NOTE:
 Information and details are only a baseline for system and installation. Modification to meet project requirement is the responsibility of the designer, architect and contractor. MetalTech-USA project staff are available to assist throughout the design and build process. © 2011 MetalTech-USA. All rights reserved.

 <p> METALTECH Global <small>a Forza Group Company</small> DESIGNING STRENGTH </p>	UNLESS OTHERWISE SPECIFIED DIMENSIONS ARE IN INCHES		DRAWING NAME: HIP/RIDGE DETAIL- OPTION 2	REVISION NO: A	DATED CREATED: 4/9/2015	
			DWG NO: MT_SSRP_1109	CHECKED BY: ESIMONSEN	APPROVED BY: ESIMONSEN	
			PROJECT NAME: RIDGE DETAILS			
	SCALE: NTS	SHEET NO: 9 OF 15	SIZE: A	TOLERANCES: ANGULAR ±1" LINEAR ±0.06		

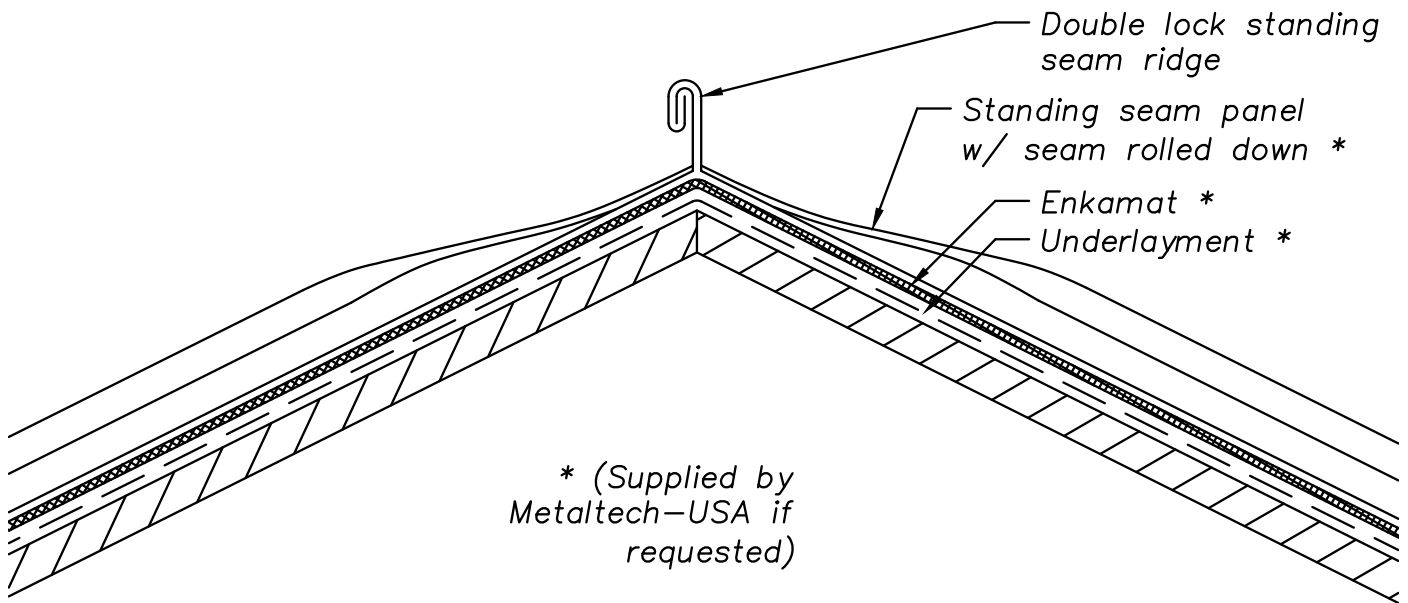

NOTE:
Panel seams must line up from one side to the other to prevent excessive material overlap.

NOTE:
Information and details are only a baseline for system and installation. Modification to meet project requirement is the responsibility of the designer, architect and contractor. MetalTech-USA project staff are available to assist throughout the design and build process. © 2011 MetalTech-USA. All rights reserved.

UNLESS OTHERWISE SPECIFIED DIMENSIONS ARE IN INCHES 	DRAWING NAME: HIP/RIDGE DETAIL- OPTION 3		REVISION NO: A	DATED CREATED: 4/9/2015
	DWG NO: MT_SSRP_1110		CHECKED BY: ESIMONSEN	APPROVED BY: ESIMONSEN
PROJECT NAME: RIDGE DETAILS				
SCALE: NTS	SHEET NO: 10 OF 15	SIZE: A	TOLERANCES: ANGULAR $\pm 1^\circ$ LINEAR ± 0.06	

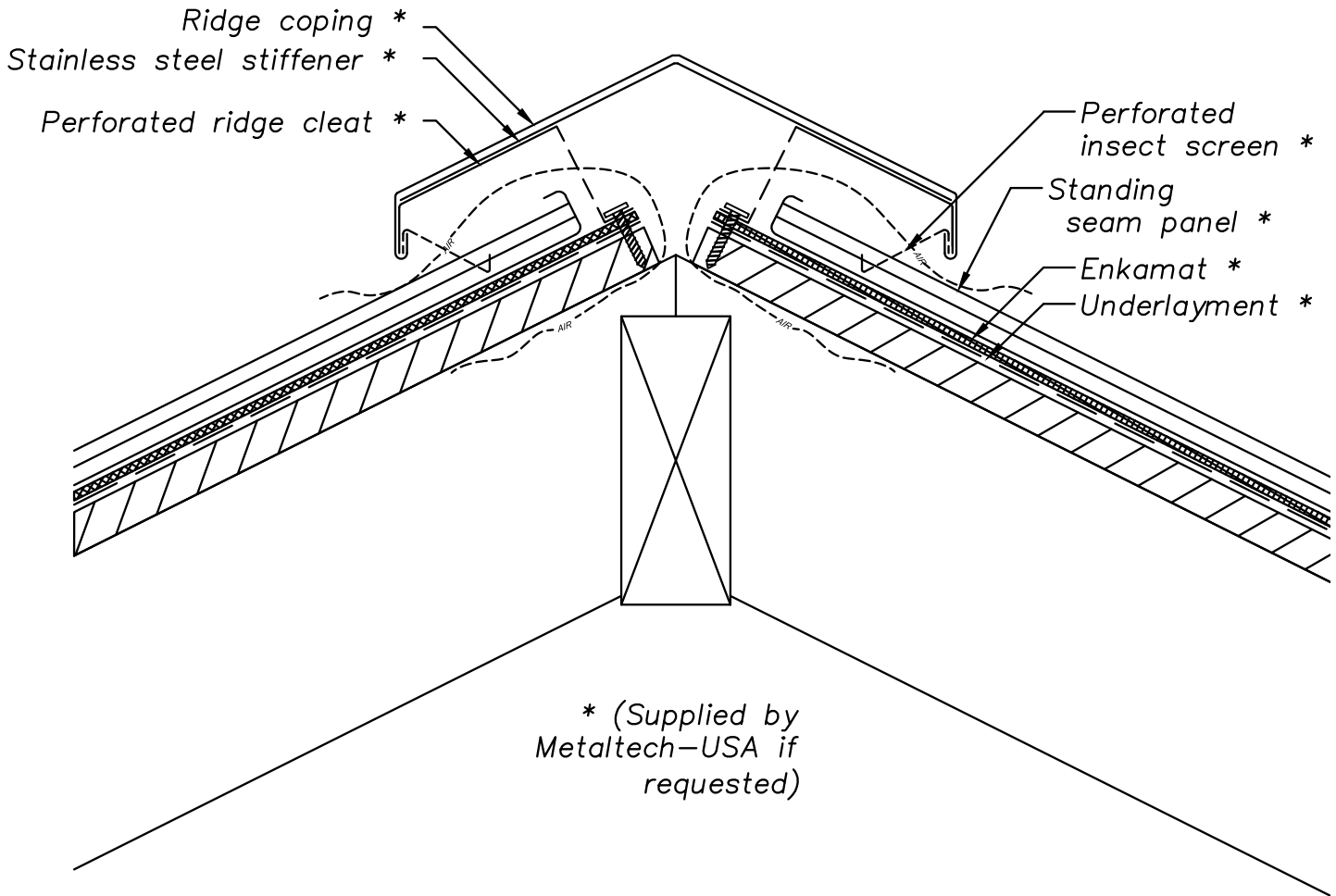

NOTE:
 Information and details are only a baseline for system and installation. Modification to meet project requirement is the responsibility of the designer, architect and contractor. MetalTech-USA project staff are available to assist throughout the design and build process. © 2011 MetalTech-USA. All rights reserved.

UNLESS OTHERWISE SPECIFIED DIMENSIONS ARE IN INCHES	DRAWING NAME: RIDGE W/ Z-SUPPORT- OPTION 1		REVISION NO: A	DATED CREATED: 4/9/2015
	DWG NO: MT_SSRP_1111		CHECKED BY: ESIMONSEN	APPROVED BY: ESIMONSEN
PROJECT NAME: RIDGE DETAILS				
SCALE: NTS		SHEET NO: 11 OF 15	SIZE: A	TOLERANCES: ANGULAR ±1° LINEAR ±0.06



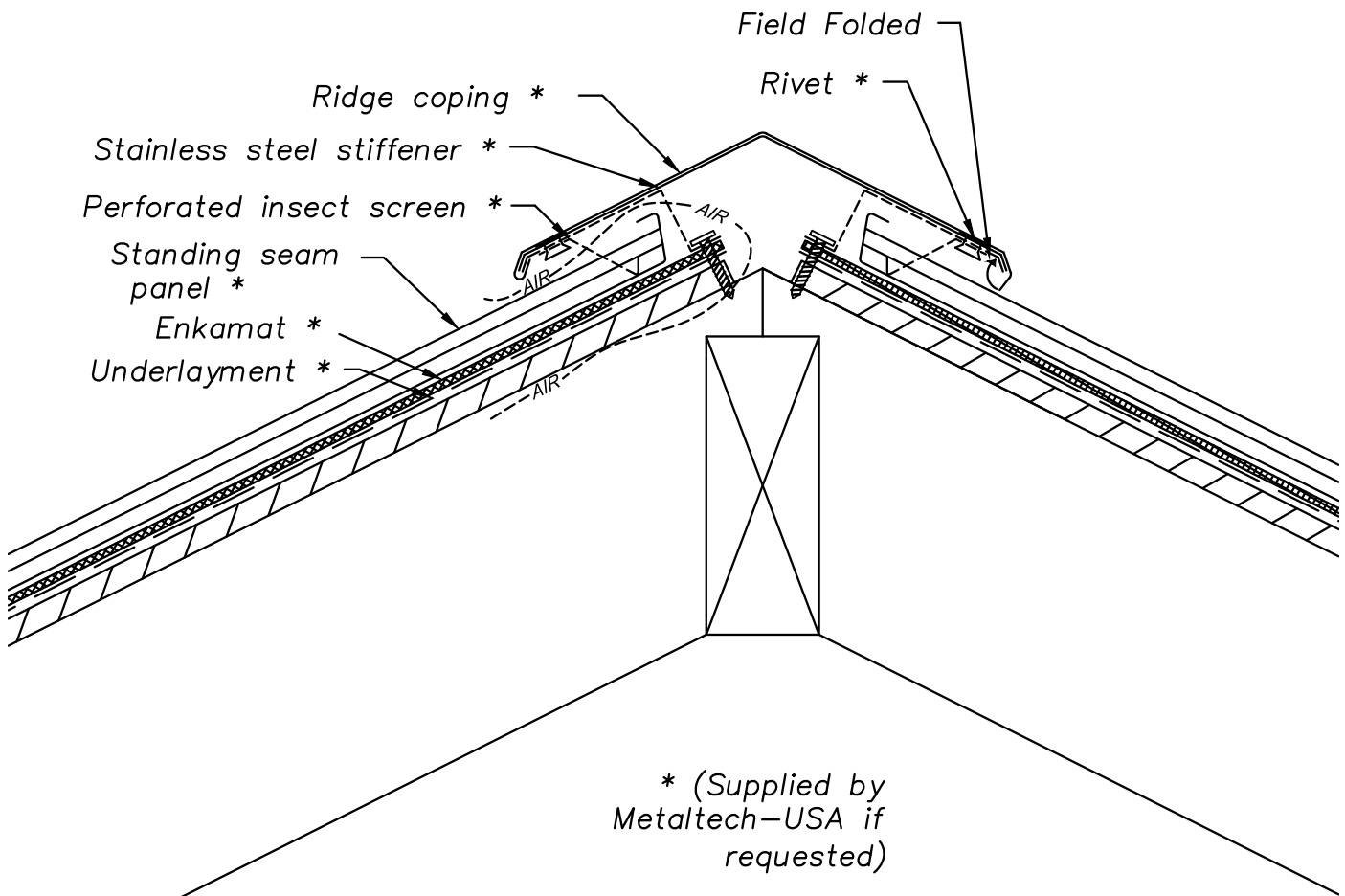

NOTE:
 Information and details are only a baseline for system and installation. Modification to meet project requirement is the responsibility of the designer, architect and contractor. MetalTech-USA project staff are available to assist throughout the design and build process. © 2011 MetalTech-USA. All rights reserved.

 <p>METALTECH Global <small>a Forza Group Company</small> DESIGNING STRENGTH</p>	DRAWING NAME: RIDGE W/ Z-SUPPORT- OPTION 2		REVISION NO: A	DATED CREATED: 4/9/2015
	DWG NO: MT_SSRP_1112		CHECKED BY: ESIMONSEN	APPROVED BY: ESIMONSEN
	PROJECT NAME: RIDGE DETAILS			
	SCALE: NTS	SHEET NO: 12 OF 15	SIZE: A	TOLERANCES: ANGULAR ±1° LINEAR ±0.06

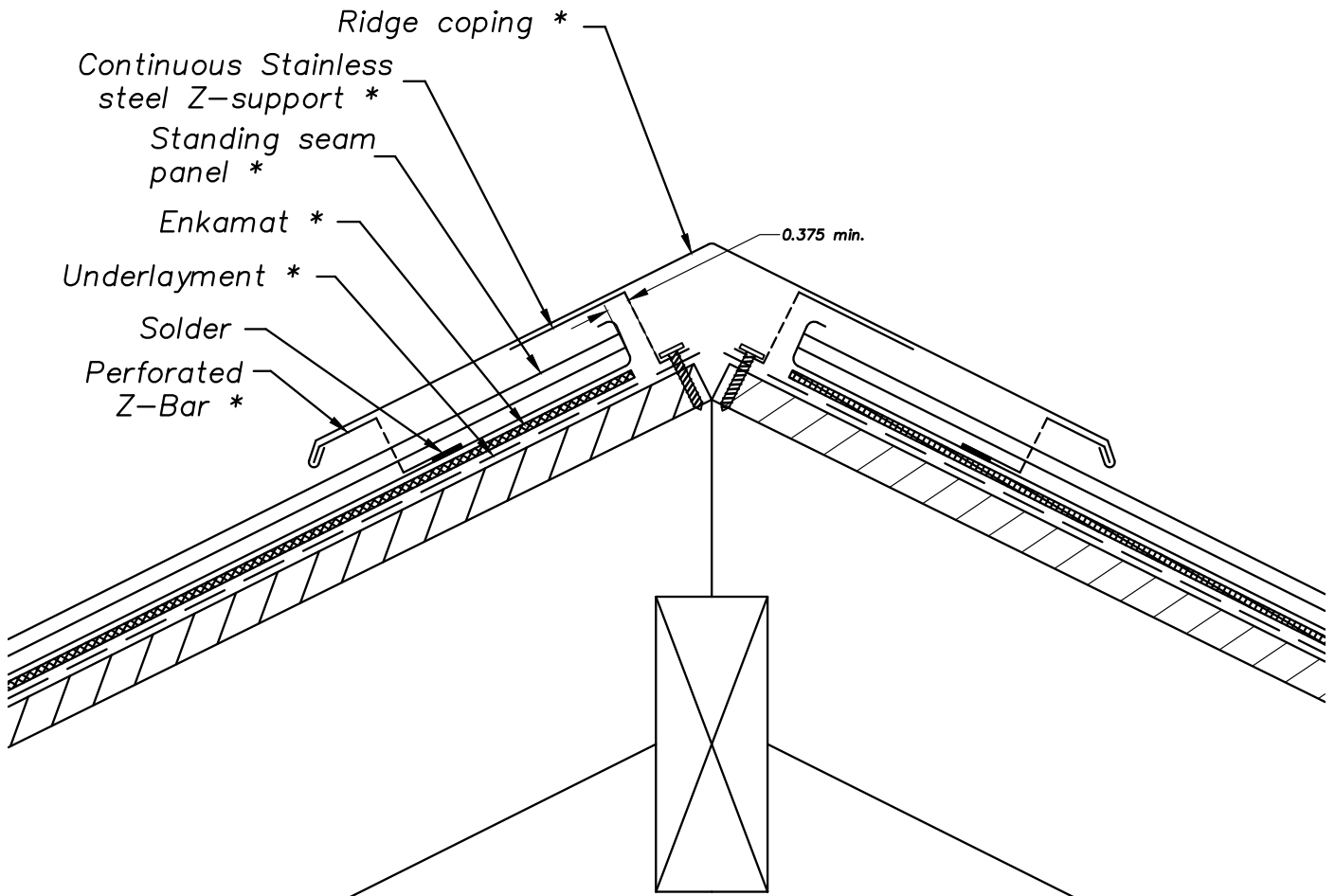

* (Supplied by Metaltech-USA if requested)

NOTE:

Information and details are only a baseline for system and installation. Modification to meet project requirement is the responsibility of the designer, architect and contractor. MetalTech-USA project staff are available to assist throughout the design and build process. © 2011 MetalTech-USA. All rights reserved.

UNLESS OTHERWISE SPECIFIED DIMENSIONS ARE IN INCHES	DRAWING NAME: RIDGE W/ Z-SUPPORT- OPTION 3		REVISION NO: A	DATED CREATED: 4/9/2015
	DWG NO: MT_SSRP_1113		CHECKED BY: ESIMONSEN	APPROVED BY: ESIMONSEN
PROJECT NAME: RIDGE DETAILS				
SCALE: NTS		SHEET NO: 13 OF 15	SIZE: A	TOLERANCES: ANGULAR ±1° LINEAR ±0.06



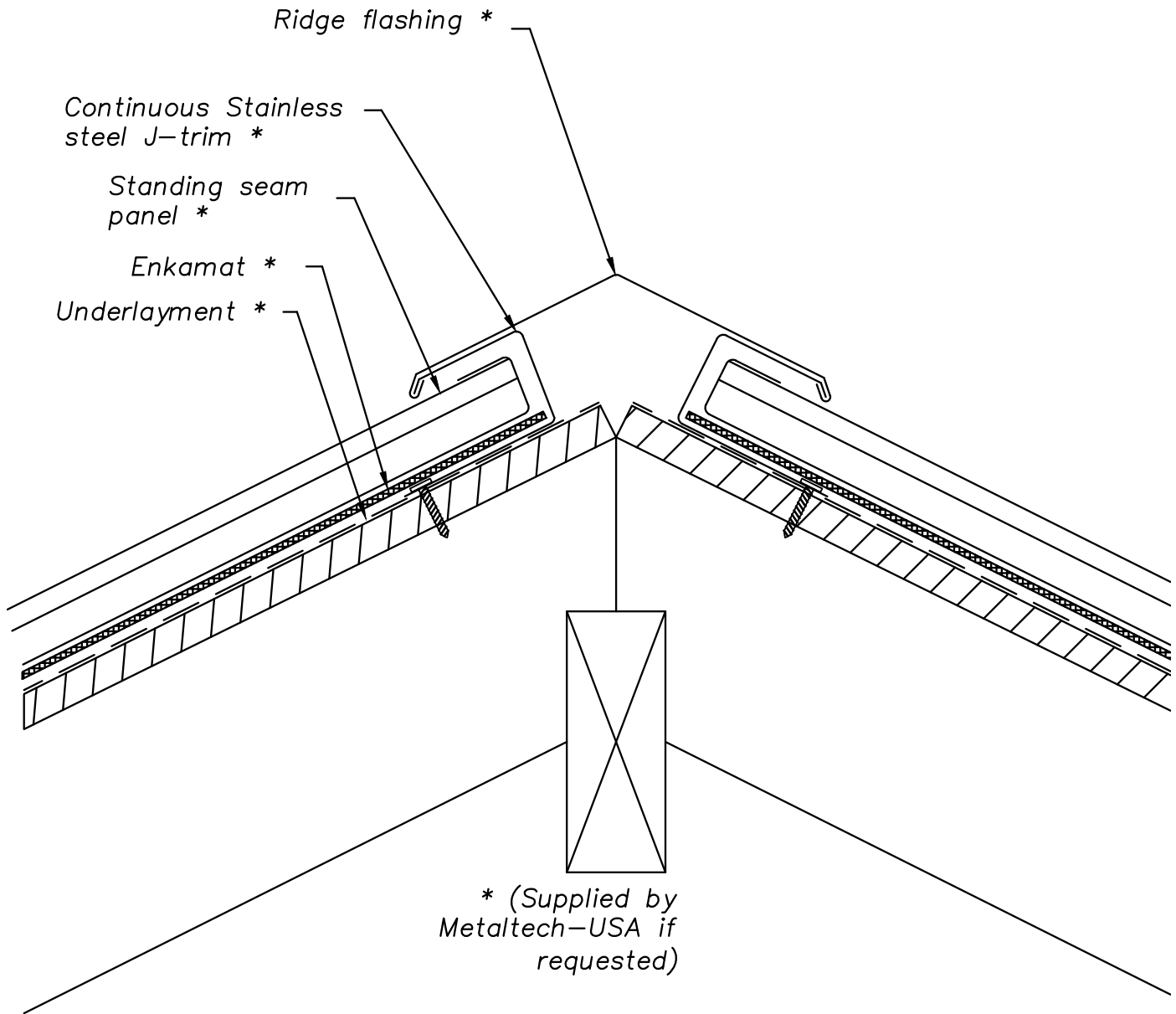

NOTE:
 Information and details are only a baseline for system and installation. Modification to meet project requirement is the responsibility of the designer, architect and contractor. MetalTech-USA project staff are available to assist throughout the design and build process. © 2011 MetalTech-USA. All rights reserved.

UNLESS OTHERWISE SPECIFIED DIMENSIONS ARE IN INCHES	DRAWING NAME: RIDGE W/ J-SUPPORT- OPTION 1		REVISION NO: A	DATED CREATED: 4/9/2015
	DWG NO: MT_SSRP_1114		CHECKED BY: ESIMONSEN	APPROVED BY: ESIMONSEN
				
PROJECT NAME: RIDGE DETAILS				
SCALE: NTS	SHEET NO: 14 OF 15	SIZE: A	TOLERANCES: ANGULAR $\pm 1^\circ$ LINEAR ± 0.06	

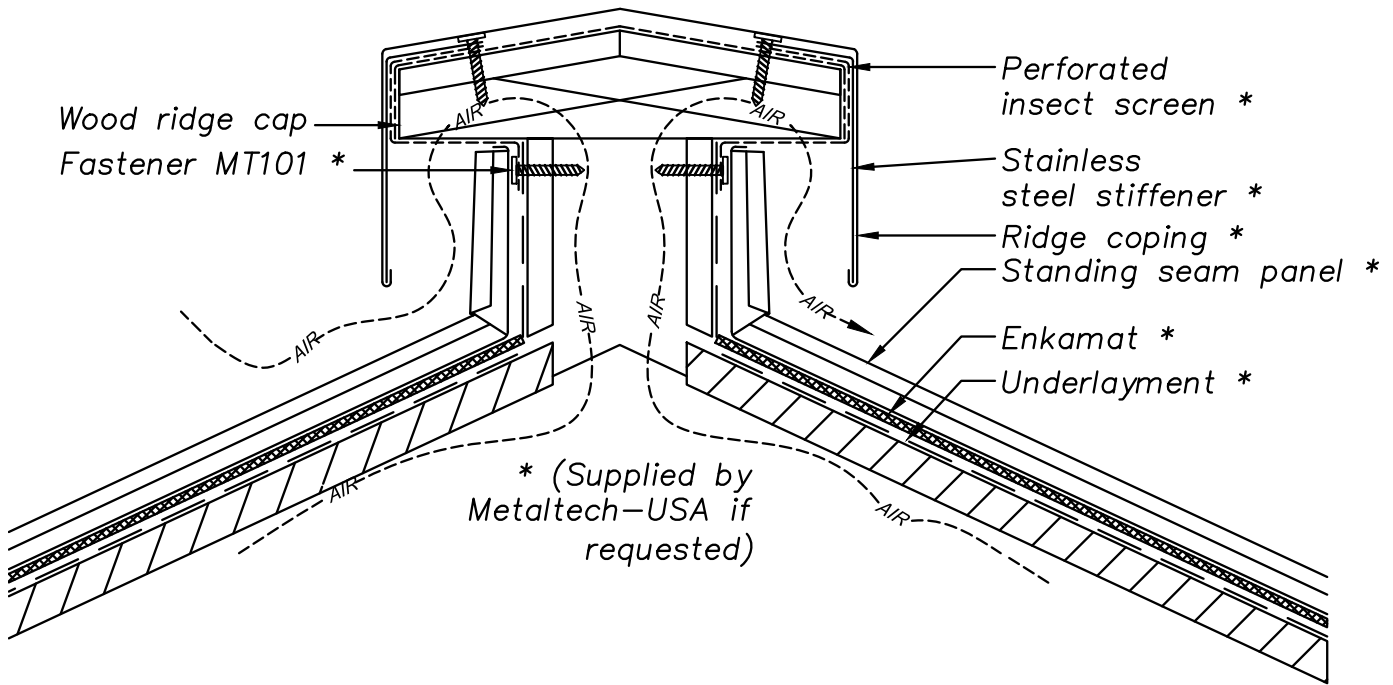

NOTE:

Information and details are only a baseline for system and installation. Modification to meet project requirement is the responsibility of the designer, architect and contractor. MetalTech-USA project staff are available to assist throughout the design and build process. © 2011 MetalTech-USA. All rights reserved.

UNLESS OTHERWISE SPECIFIED DIMENSIONS ARE IN INCHES	DRAWING NAME: HEAVY DUTY VENTILATED RIDGE		REVISION NO: A	DATED CREATED: 4/9/2015	
	DWG NO: MT_SSRP_1115		CHECKED BY: ESIMONSEN	APPROVED BY: ESIMONSEN	
	PROJECT NAME: RIDGE DETAILS				
	SCALE: NTS	SHEET NO: 15 OF 15	SIZE: A	TOLERANCES: ANGULAR $\pm 1^\circ$ LINEAR ± 0.06	

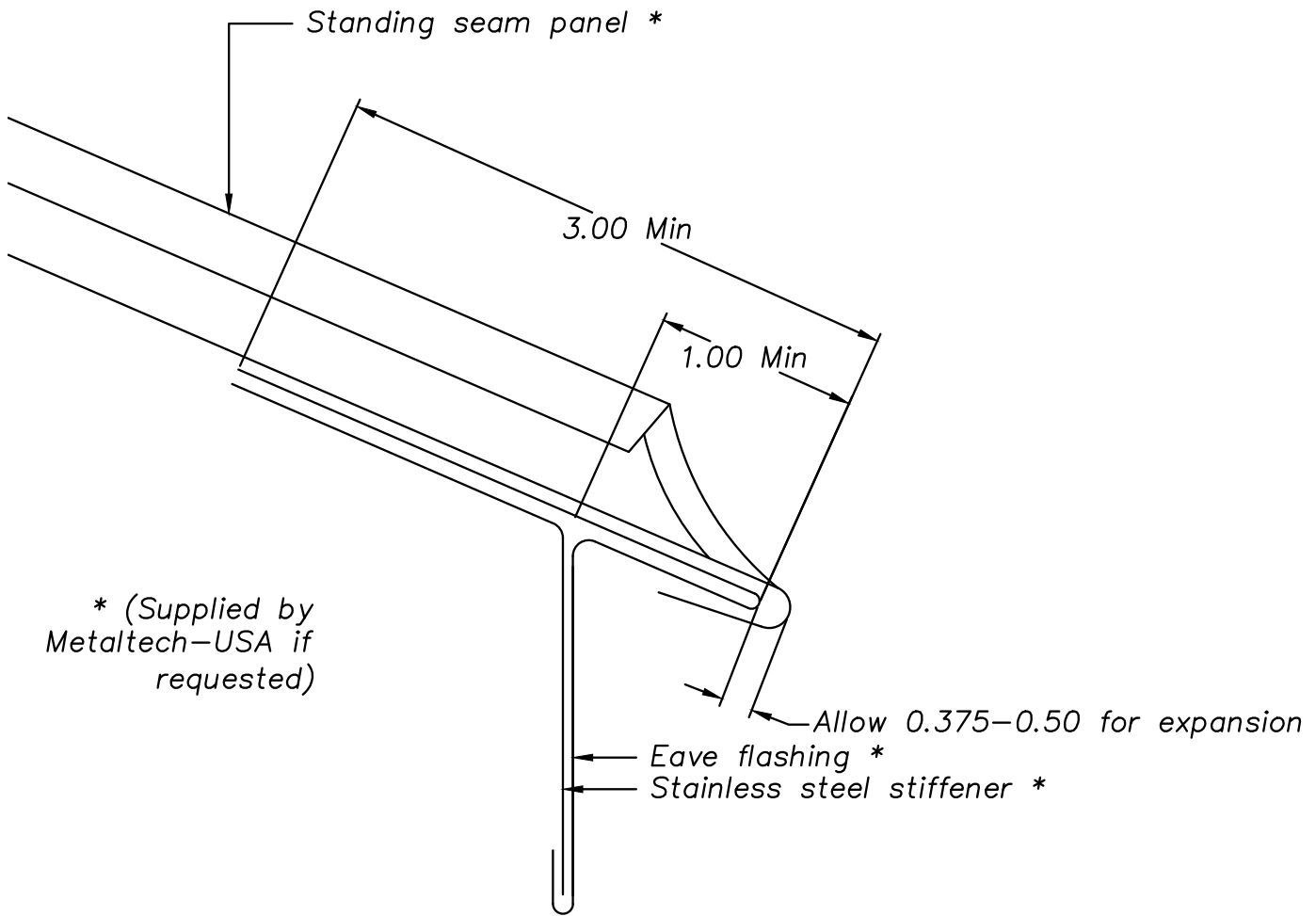

NOTE:
 Information and details are only a baseline for system and installation. Modification to meet project requirement is the responsibility of the designer, architect and contractor. MetalTech-USA project staff are available to assist throughout the design and build process. © 2011 MetalTech-USA. All rights reserved.

UNLESS OTHERWISE SPECIFIED DIMENSIONS ARE IN INCHES	DRAWING NAME: TYPICAL EAVE SECTION		REVISION NO: A	DATED CREATED: 5/23/2015	
	DWG NO: MT_SSRP_1201		CHECKED BY: ESIMONSEN	APPROVED BY: ESIMONSEN	
	PROJECT NAME: EAVE DETAILS				
	SCALE: NTS	SHEET NO: 1 OF 11	SIZE: A	TOLERANCES: ANGULAR $\pm 1^\circ$ LINEAR ± 0.06	

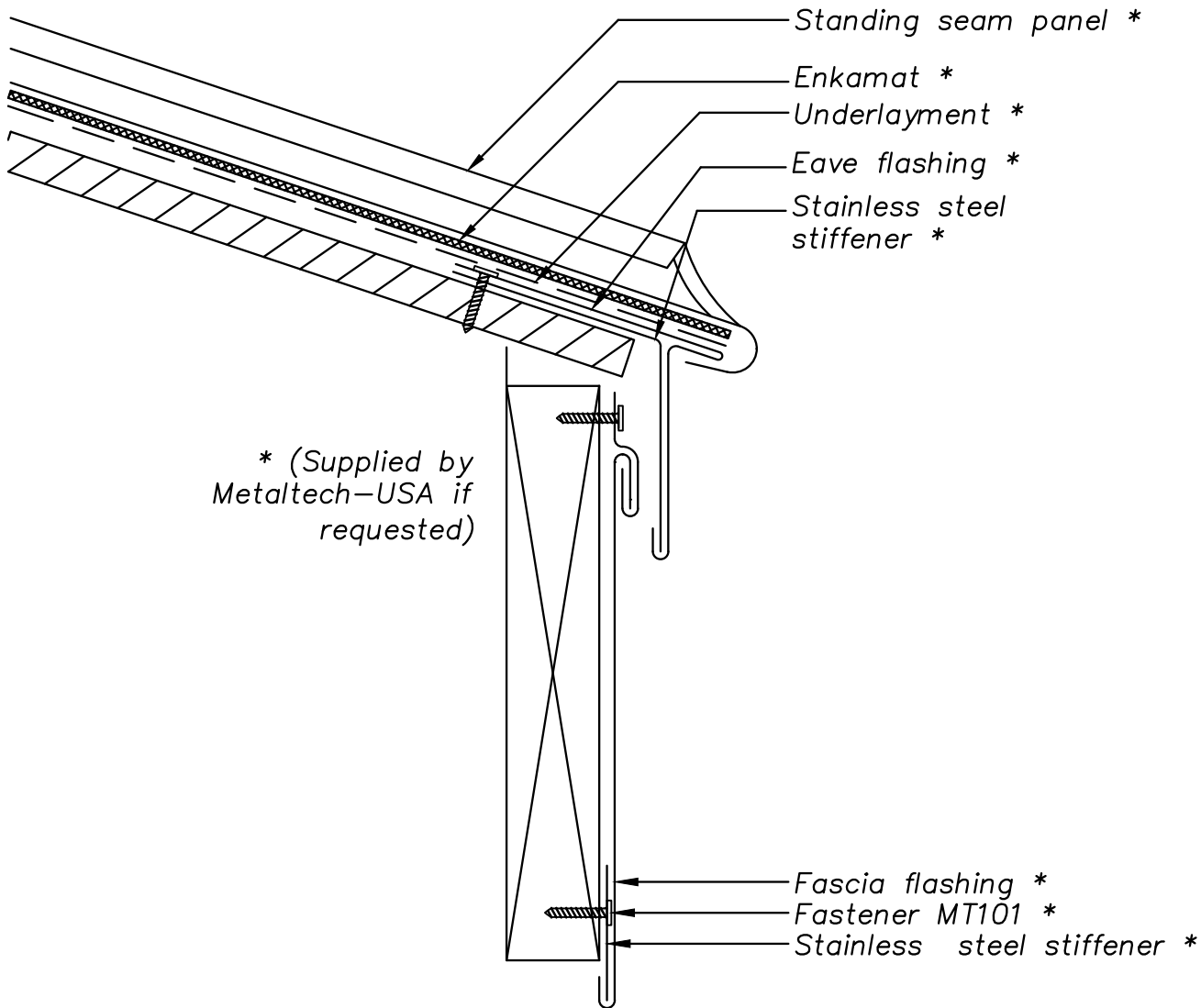

NOTE:
 Information and details are only a baseline for system and installation. Modification to meet project requirement is the responsibility of the designer, architect and contractor. MetalTech-USA project staff are available to assist throughout the design and build process. © 2011 MetalTech-USA. All rights reserved.

UNLESS OTHERWISE SPECIFIED DIMENSIONS ARE IN INCHES	DRAWING NAME: FASCIA – OPTION 1		REVISION NO: A	DATED CREATED: 5/23/2015
	DWG NO: MT_SSRP_1202		CHECKED BY: ESIMONSEN	APPROVED BY: ESIMONSEN
PROJECT NAME: EAVE DETAILS				
SCALE: NTS		SHEET NO: 2 OF 11	SIZE: A	TOLERANCES: ANGULAR ±1° LINEAR ±0.06



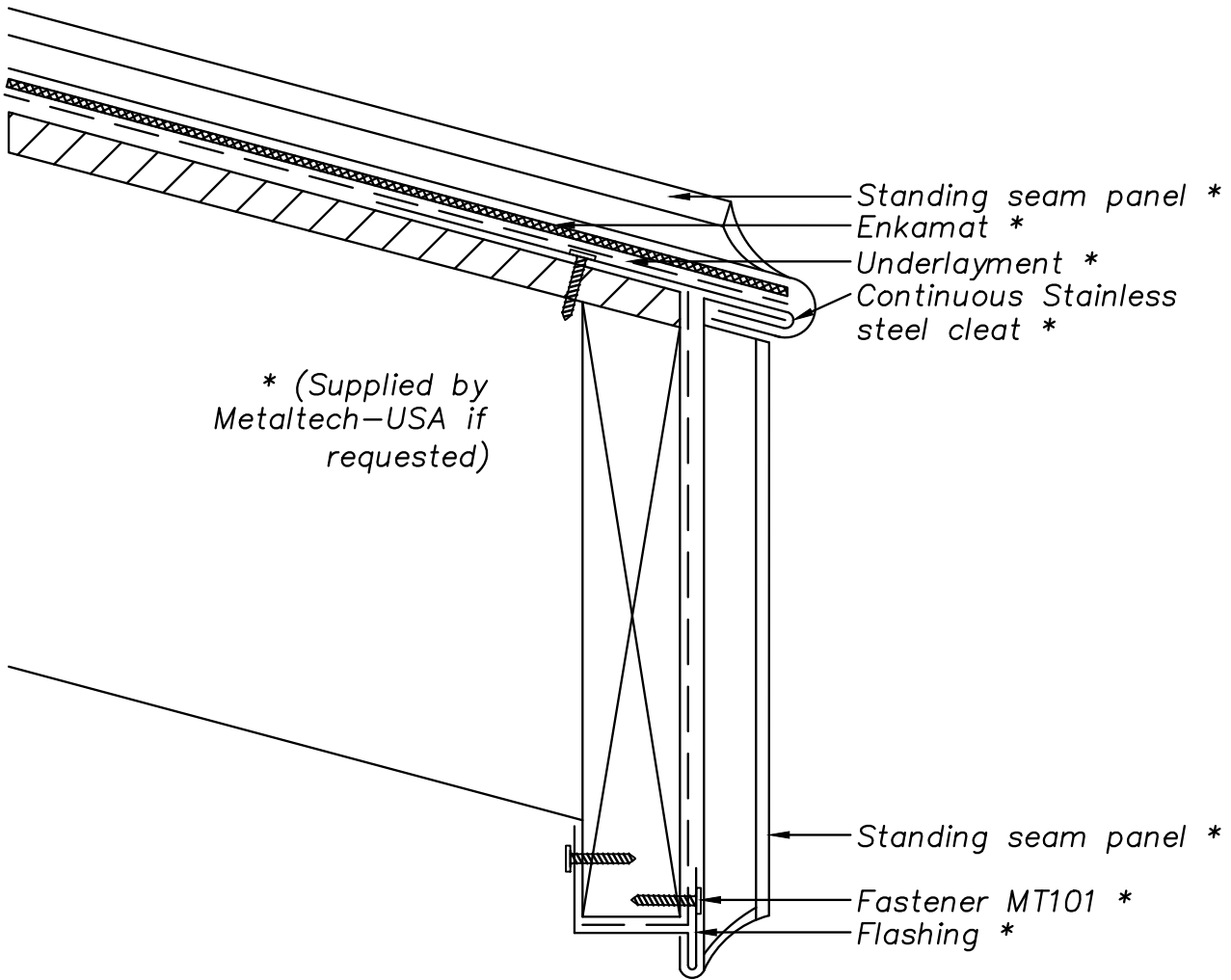

NOTE:
 Information and details are only a baseline for system and installation. Modification to meet project requirement is the responsibility of the designer, architect and contractor. MetalTech-USA project staff are available to assist throughout the design and build process. © 2011 MetalTech-USA. All rights reserved.

 <small>a Forza Group Company</small> DESIGNING STRENGTH	UNLESS OTHERWISE SPECIFIED DIMENSIONS ARE IN INCHES		DRAWING NAME: FASCIA - OPTION 2	REVISION NO: A	DATED CREATED: 5/23/2015	
	DWG NO: MT_SSRP_1203		PROJECT NAME: EAVE DETAILS	CHECKED BY: ESIMONSEN	APPROVED BY: ESIMONSEN	
	SCALE: NTS	SHEET NO: 3 OF 11	SIZE: A	TOLERANCES: ANGULAR $\pm 1^\circ$ LINEAR ± 0.06		

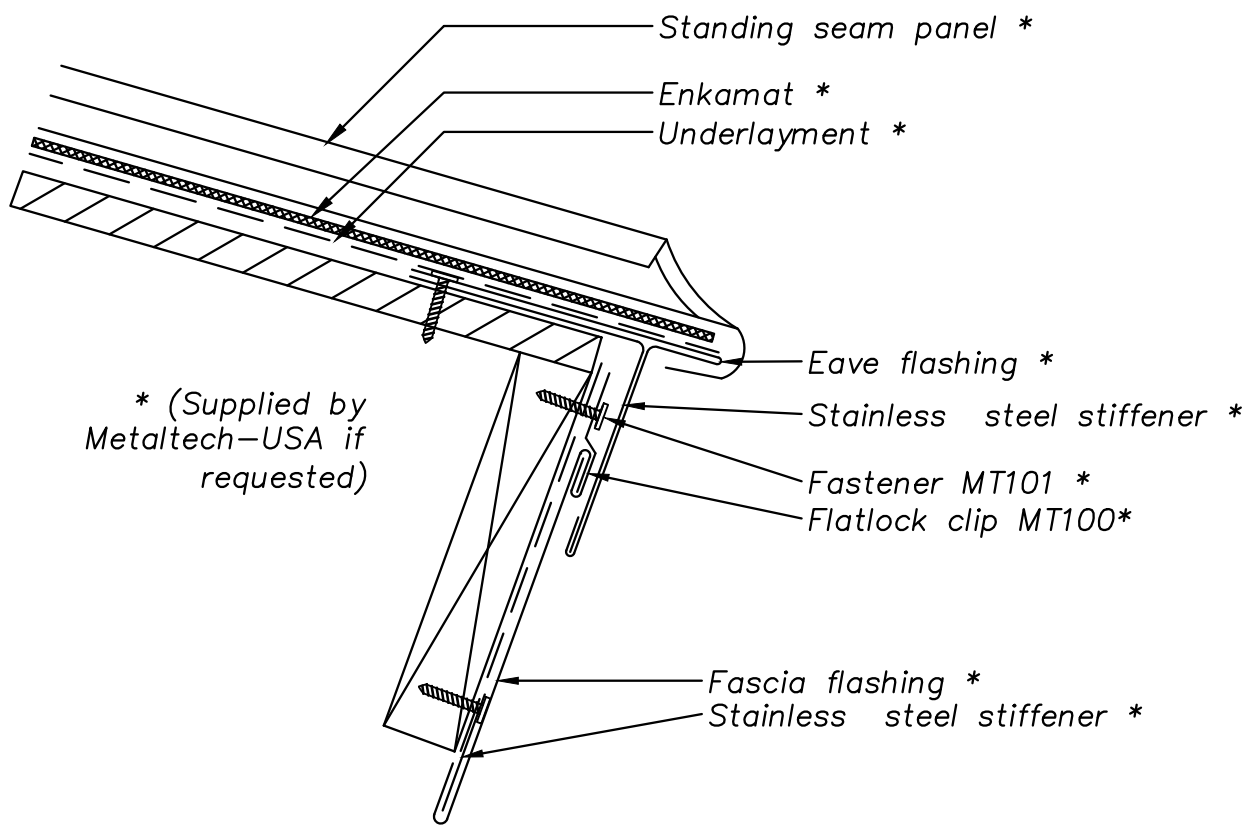

NOTE:
 Information and details are only a baseline for system and installation. Modification to meet project requirement is the responsibility of the designer, architect and contractor. MetalTech-USA project staff are available to assist throughout the design and build process. © 2011 MetalTech-USA. All rights reserved.

UNLESS OTHERWISE SPECIFIED DIMENSIONS ARE IN INCHES	DRAWING NAME: FASCIA - OPTION 3		REVISION NO: A	DATED CREATED: 5/23/2015
	DWG NO: MT_SSRP_1204		CHECKED BY: ESIMONSEN	APPROVED BY: ESIMONSEN
PROJECT NAME: EAVE DETAILS				
SCALE: NTS		SHEET NO: 4 OF 11	SIZE: A	TOLERANCES: ANGULAR ±1° LINEAR ±0.06



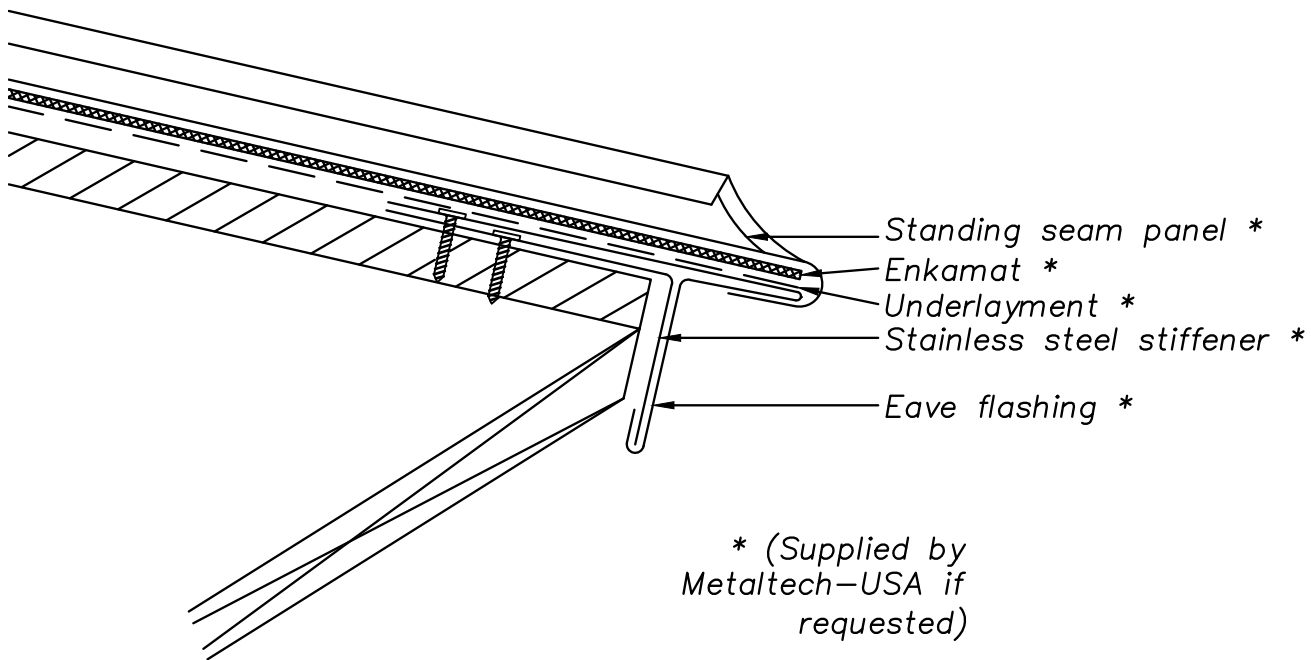

NOTE:
 Information and details are only a baseline for system and installation. Modification to meet project requirement is the responsibility of the designer, architect and contractor. MetalTech-USA project staff are available to assist throughout the design and build process. © 2011 MetalTech-USA. All rights reserved.

UNLESS OTHERWISE SPECIFIED DIMENSIONS ARE IN INCHES	DRAWING NAME: FASCIA - OPTION 4	REVISION NO: A	DATED CREATED: 5/23/2015
	DWG NO: MT_SSRP_1205	CHECKED BY: ESIMONSEN	APPROVED BY: ESIMONSEN
	PROJECT NAME: EAVE DETAILS		
	SCALE: NTS	SHEET NO: 5 OF 11	SIZE: A
TOLERANCES: ANGULAR ±1° LINEAR ±0.06			

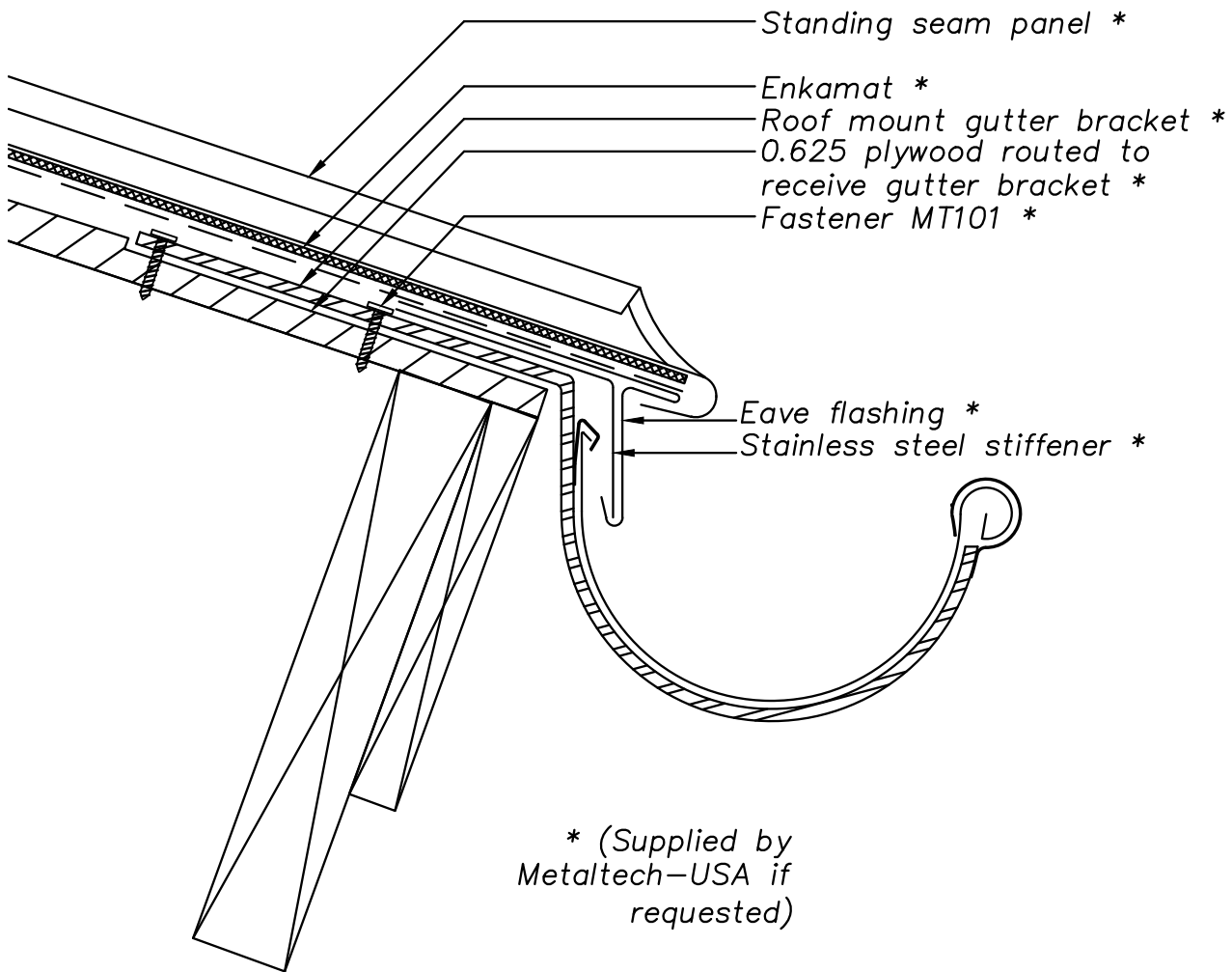

NOTE:
 Information and details are only a baseline for system and installation. Modification to meet project requirement is the responsibility of the designer, architect and contractor. MetalTech-USA project staff are available to assist throughout the design and build process. © 2011 MetalTech-USA. All rights reserved.

UNLESS OTHERWISE SPECIFIED DIMENSIONS ARE IN INCHES	DRAWING NAME: EAVE WITH GUTTER – OPTION 1		REVISION NO: A	DATED CREATED: 5/23/2015	
	DWG NO: MT_SSRP_1206		CHECKED BY: ESIMONSEN	APPROVED BY: ESIMONSEN	
 a Forza Group Company DESIGNING STRENGTH	PROJECT NAME: EAVE DETAILS				
	SCALE: NTS	SHEET NO: 6 OF 11	SIZE: A	TOLERANCES: ANGULAR $\pm 1^\circ$ LINEAR ± 0.06	

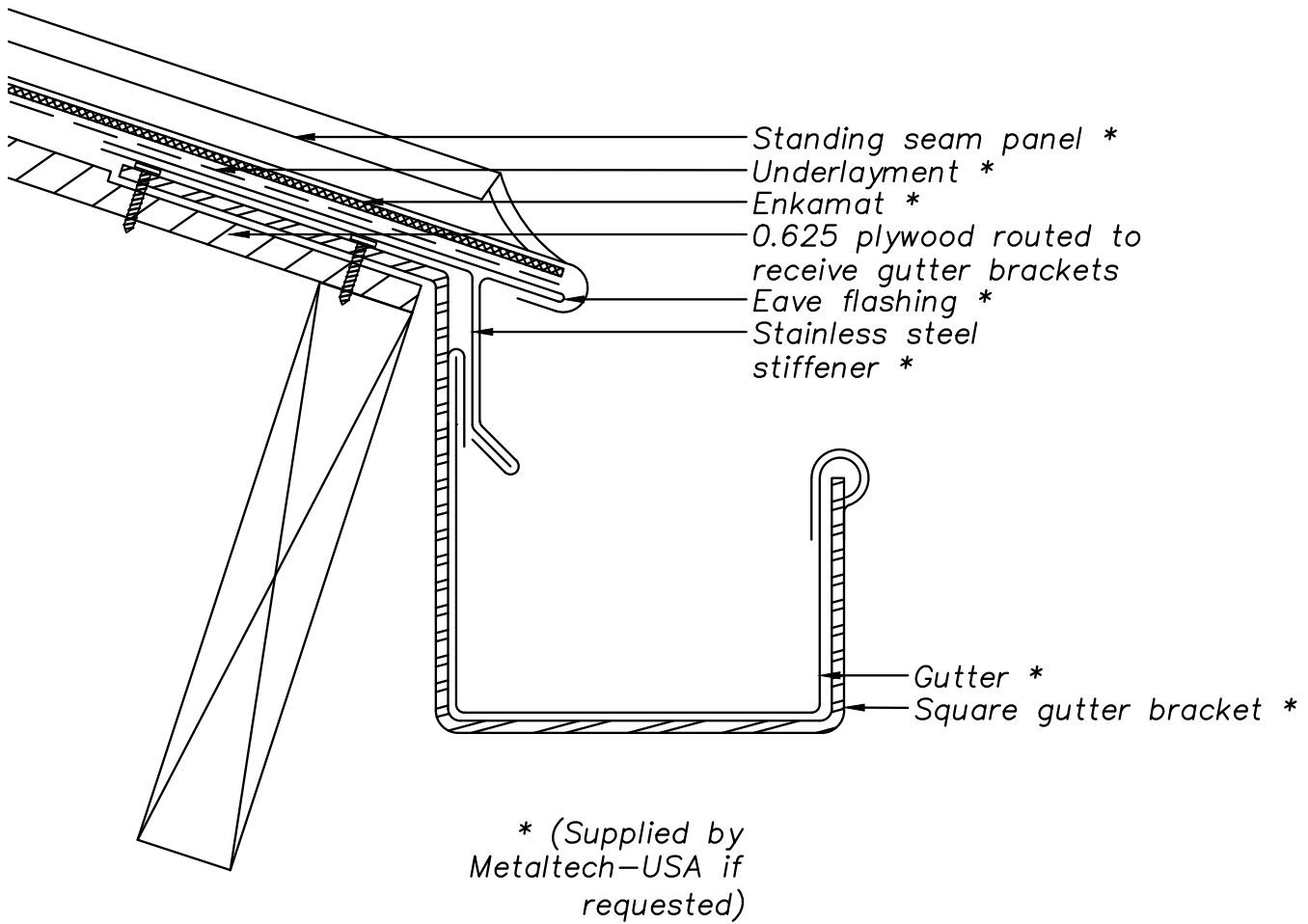

NOTE:
 Information and details are only a baseline for system and installation. Modification to meet project requirement is the responsibility of the designer, architect and contractor. MetalTech-USA project staff are available to assist throughout the design and build process. © 2011 MetalTech-USA. All rights reserved.

UNLESS OTHERWISE SPECIFIED DIMENSIONS ARE IN INCHES	DRAWING NAME: EAVE WITH GUTTER - OPTION 2		REVISION NO: A	DATED CREATED: 5/23/2015	
	DWG NO: MT_SSRP_1207		CHECKED BY: ESIMONSEN	APPROVED BY: ESIMONSEN	
 a Forza Group Company DESIGNING STRENGTH	PROJECT NAME: EAVE DETAILS				
	SCALE: NTS	SHEET NO: 7 OF 11	SIZE: A	TOLERANCES: ANGULAR $\pm 1^\circ$ LINEAR ± 0.06	

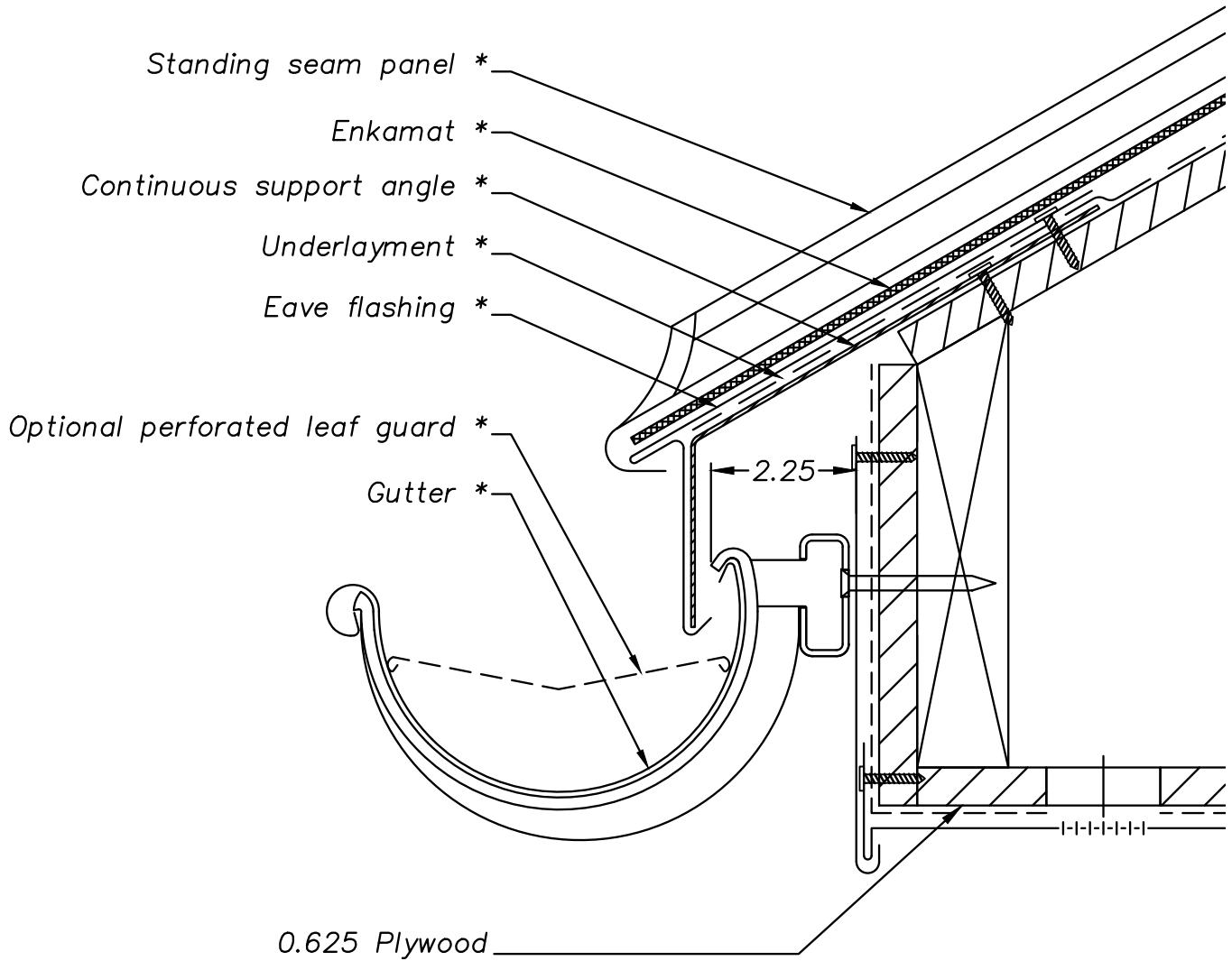

* (Supplied by
Metaltech-USA if
requested)

NOTE:

Information and details are only a baseline for system and installation. Modification to meet project requirement is the responsibility of the designer, architect and contractor. MetalTech-USA project staff are available to assist throughout the design and build process. © 2011 MetalTech-USA. All rights reserved.

<p>UNLESS OTHERWISE SPECIFIED DIMENSIONS ARE IN INCHES</p>	<p>DRAWING NAME: EAVE WITH GUTTER – OPTION 3</p>		<p>REVISION NO: A</p>	<p>DATED CREATED: 5/23/2015</p>	
	<p>DWG NO: MT_SSRP_1208</p>		<p>CHECKED BY: ESIMONSEN</p>	<p>APPROVED BY: ESIMONSEN</p>	
 <p>METALTECH Global a Forza Group Company DESIGNING STRENGTH</p>	<p>PROJECT NAME: EAVE DETAILS</p>				
	<p>SCALE: NTS</p>	<p>SHEET NO: 8 OF 11</p>	<p>SIZE: A</p>	<p>TOLERANCES: ANGULAR ±1° LINEAR ±0.06</p>	

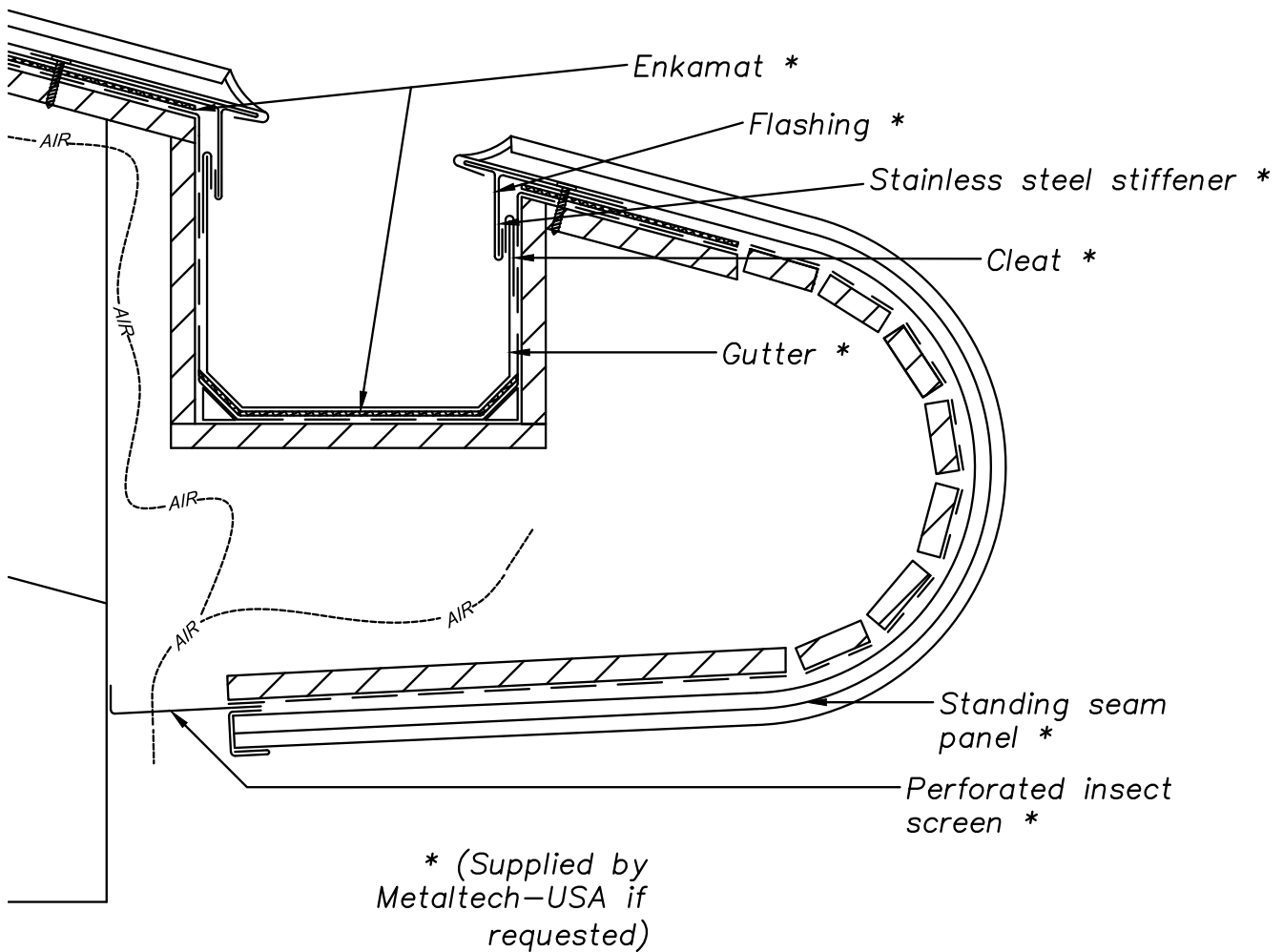

NOTE:

Information and details are only a baseline for system and installation. Modification to meet project requirement is the responsibility of the designer, architect and contractor. MetalTech-USA project staff are available to assist throughout the design and build process. © 2011 MetalTech-USA. All rights reserved.

	UNLESS OTHERWISE SPECIFIED DIMENSIONS ARE IN INCHES		DRAWING NAME: BUILT IN GUTTER – OPTION 1	REVISION NO: A	DATED CREATED: 5/23/2015
	DWG NO: MT_SSRP_1209		CHECKED BY: ESIMONSEN		APPROVED BY: ESIMONSEN
PROJECT NAME: EAVE DETAILS					
SCALE: NTS	SHEET NO: 9 OF 11	SIZE: A	TOLERANCES: ANGULAR ±1° LINEAR ±0.06		

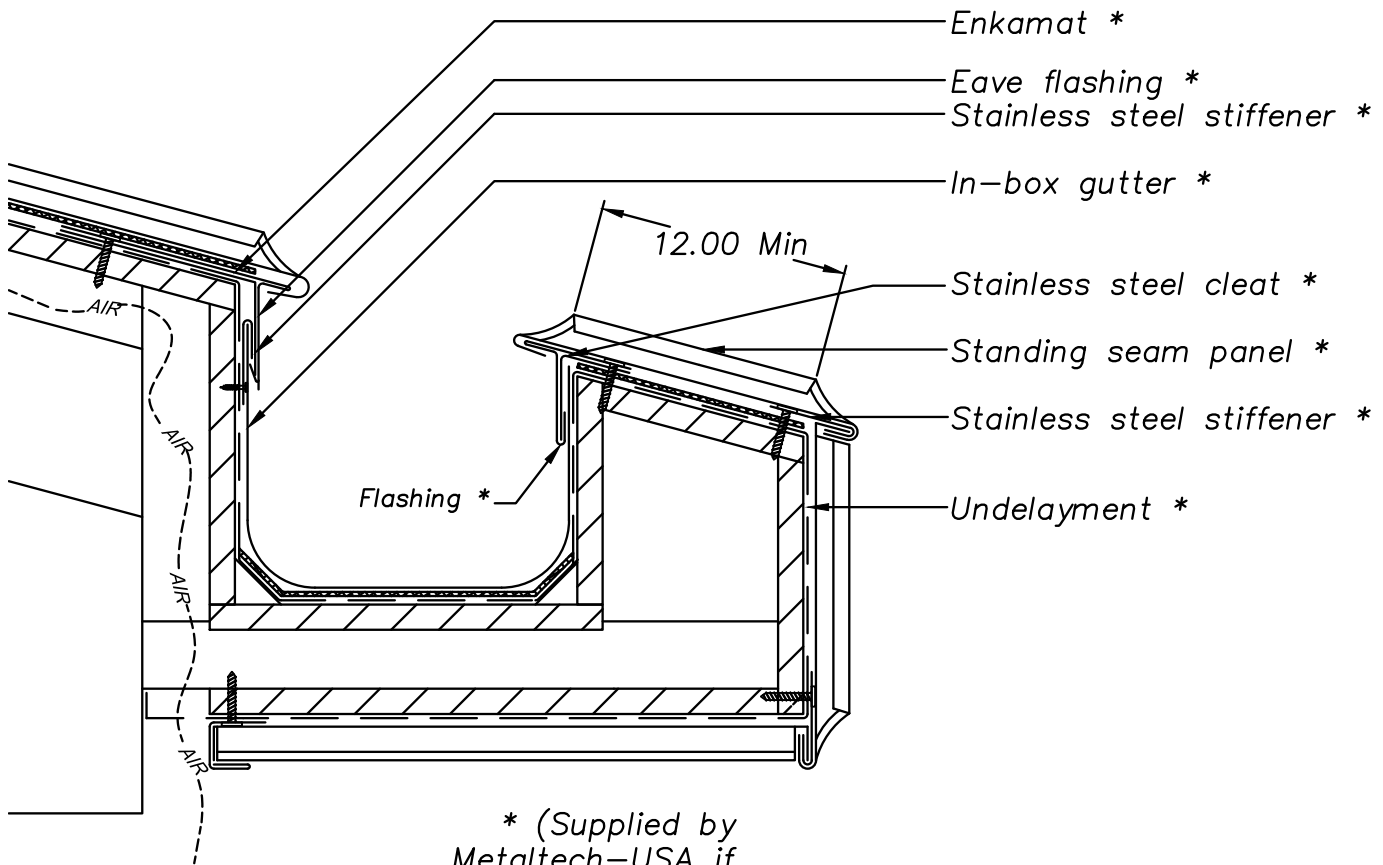

* (Supplied by
Metaltech-USA if
requested)

NOTE:

Information and details are only a baseline for system and installation. Modification to meet project requirement is the responsibility of the designer, architect and contractor. MetalTech-USA project staff are available to assist throughout the design and build process. © 2011 MetalTech-USA. All rights reserved.

UNLESS OTHERWISE SPECIFIED DIMENSIONS ARE IN INCHES	DRAWING NAME: BUILT IN GUTTER - OPTION 2		REVISION NO: A	DATED CREATED: 5/23/2015
	DWG NO: MT_SSRP_1210		CHECKED BY: ESIMONSEN	APPROVED BY: ESIMONSEN
				
PROJECT NAME: EAVE DETAILS				
SCALE: NTS	SHEET NO: 10 OF 11	SIZE: A	TOLERANCES: ANGULAR $\pm 1^\circ$ LINEAR ± 0.06	

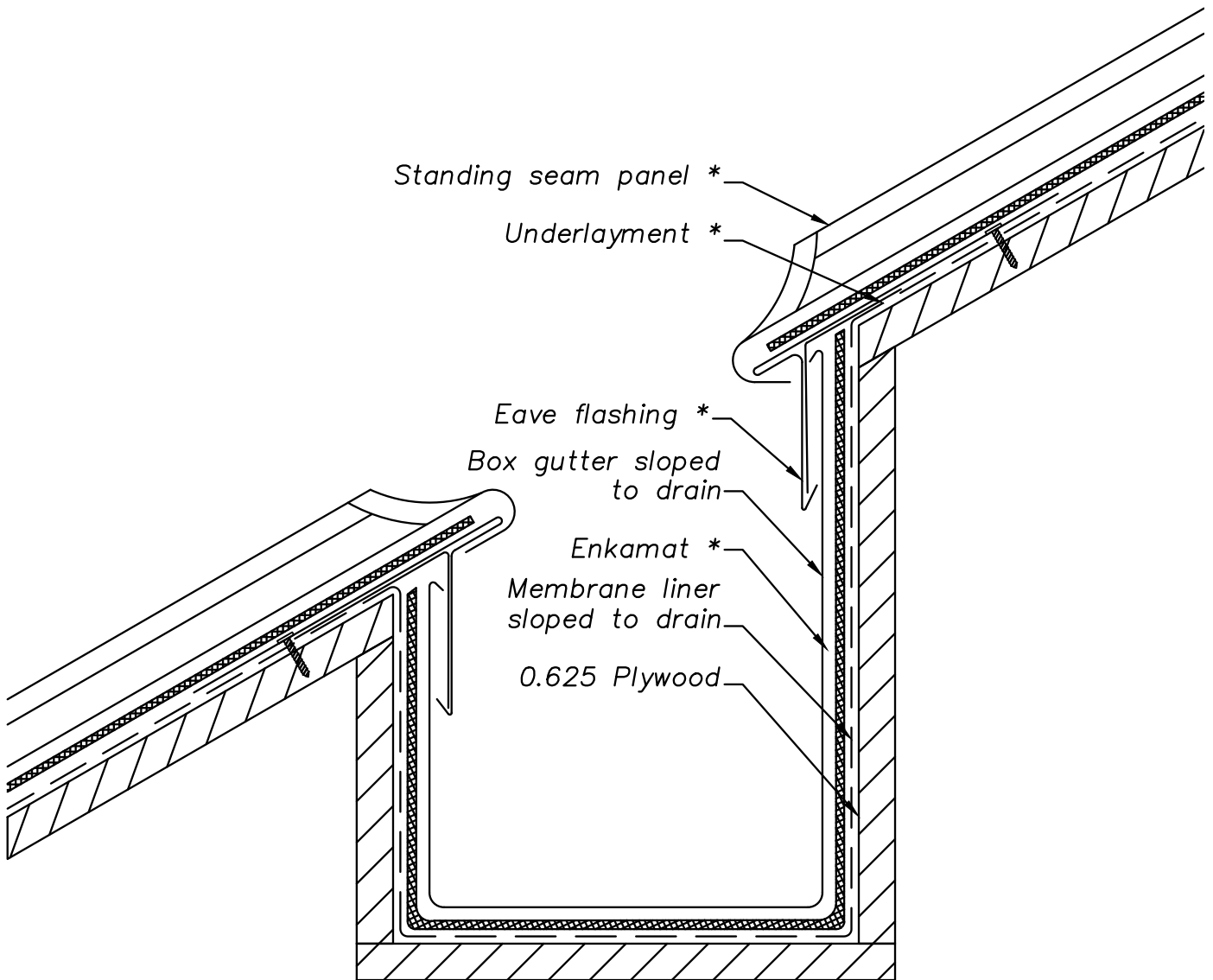

* (Supplied by
Metaltech-USA if
requested)

NOTE:

Information and details are only a baseline for system and installation. Modification to meet project requirement is the responsibility of the designer, architect and contractor. MetalTech-USA project staff are available to assist throughout the design and build process. © 2011 MetalTech-USA. All rights reserved.

UNLESS OTHERWISE SPECIFIED DIMENSIONS ARE IN INCHES	DRAWING NAME: BUILT IN GUTTER – OPTION 3		REVISION NO: A	DATED CREATED: 5/23/2015
	DWG NO: MT_SSRP_1211		CHECKED BY: ESIMONSEN	APPROVED BY: ESIMONSEN
PROJECT NAME: EAVE DETAILS				
SCALE: NTS		SHEET NO: 11 OF 11	SIZE: A	TOLERANCES: ANGULAR ±1° LINEAR ±0.06



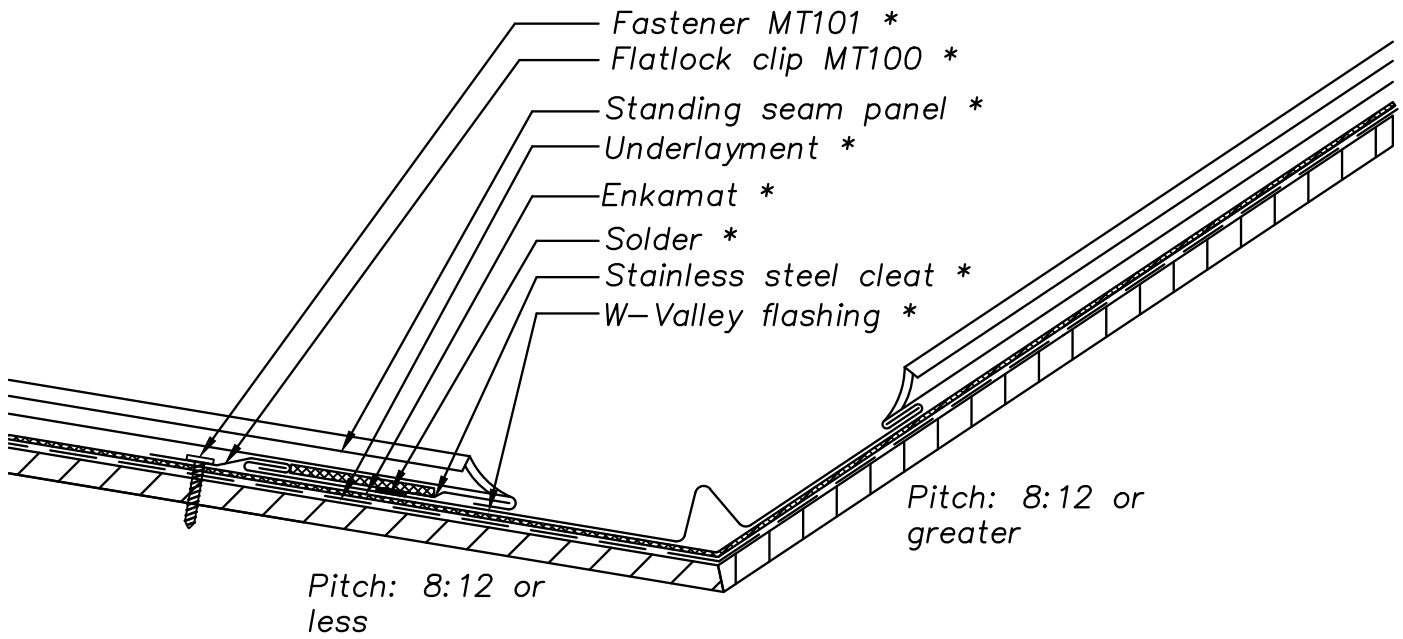

* (Supplied by
Metaltech-USA if
requested)

NOTE:

Information and details are only a baseline for system and installation. Modification to meet project requirement is the responsibility of the designer, architect and contractor. MetalTech-USA project staff are available to assist throughout the design and build process. © 2011 MetalTech-USA. All rights reserved.

UNLESS OTHERWISE SPECIFIED DIMENSIONS ARE IN INCHES	DRAWING NAME: TYPICAL VALLEY SECTION		REVISION NO: A	DATED CREATED: 5/24/2015	
	DWG NO: MT_SSRP_1301		CHECKED BY: ESIMONSEN	APPROVED BY: ESIMONSEN	
	PROJECT NAME: VALLEY DETAILS				
	SCALE: NTS	SHEET NO: 1 OF 6	SIZE: A	TOLERANCES: ANGULAR ±1° LINEAR ±0.06	

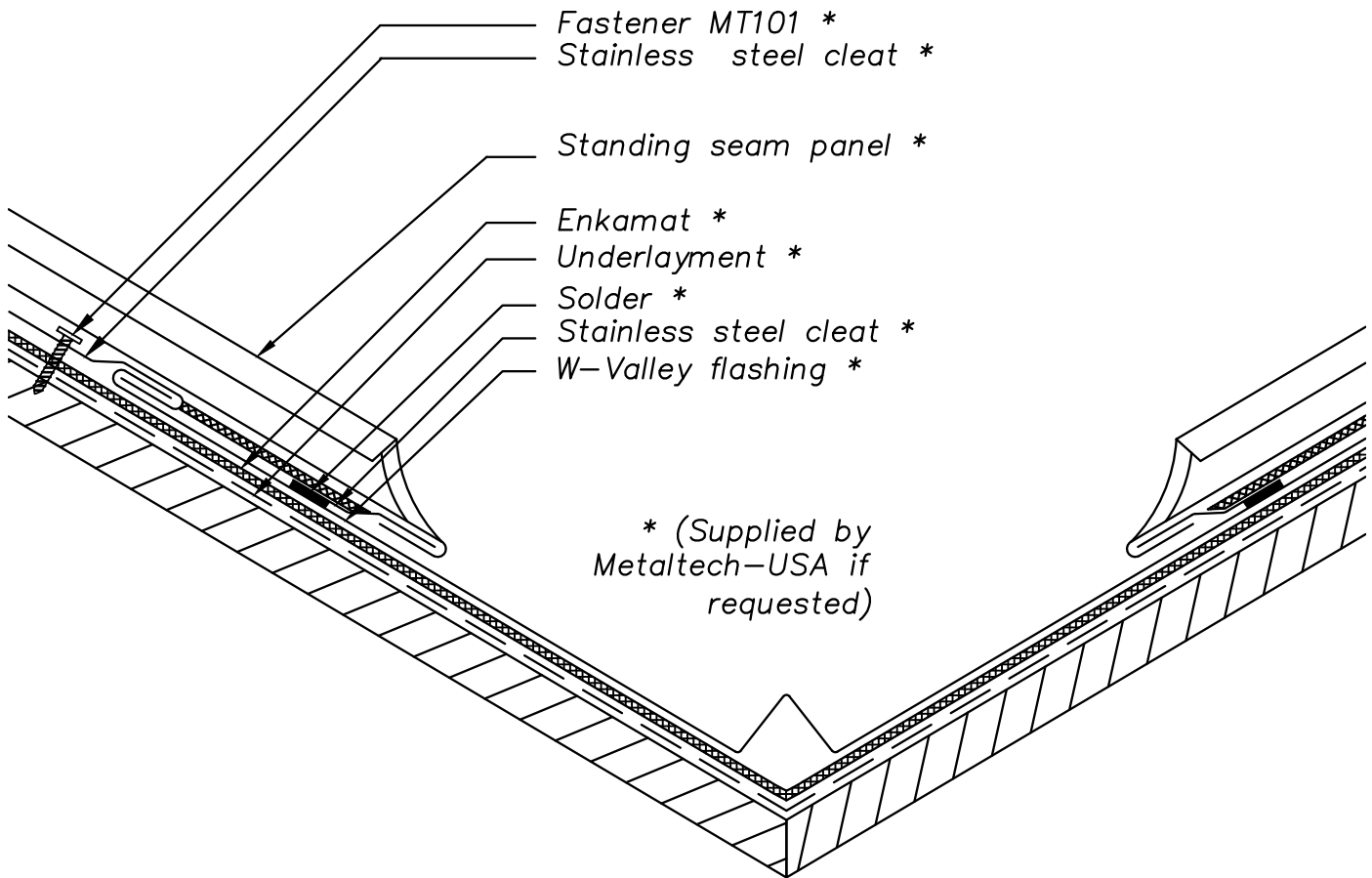

NOTE:
 Information and details are only a baseline for system and installation. Modification to meet project requirement is the responsibility of the designer, architect and contractor. MetalTech-USA project staff are available to assist throughout the design and build process. © 2011 MetalTech-USA. All rights reserved.

UNLESS OTHERWISE SPECIFIED DIMENSIONS ARE IN INCHES	DRAWING NAME: VALLEY DETAIL – OPTION 1		REVISION NO: A	DATED CREATED: 5/24/2015	
	DWG NO: MT_SSRP_1302		CHECKED BY: ESIMONSEN	APPROVED BY: ESIMONSEN	
	PROJECT NAME: VALLEY DETAILS				
	SCALE: NTS	SHEET NO: 2 OF 6	SIZE: A	TOLERANCES: ANGULAR $\pm 1^\circ$ LINEAR ± 0.06	

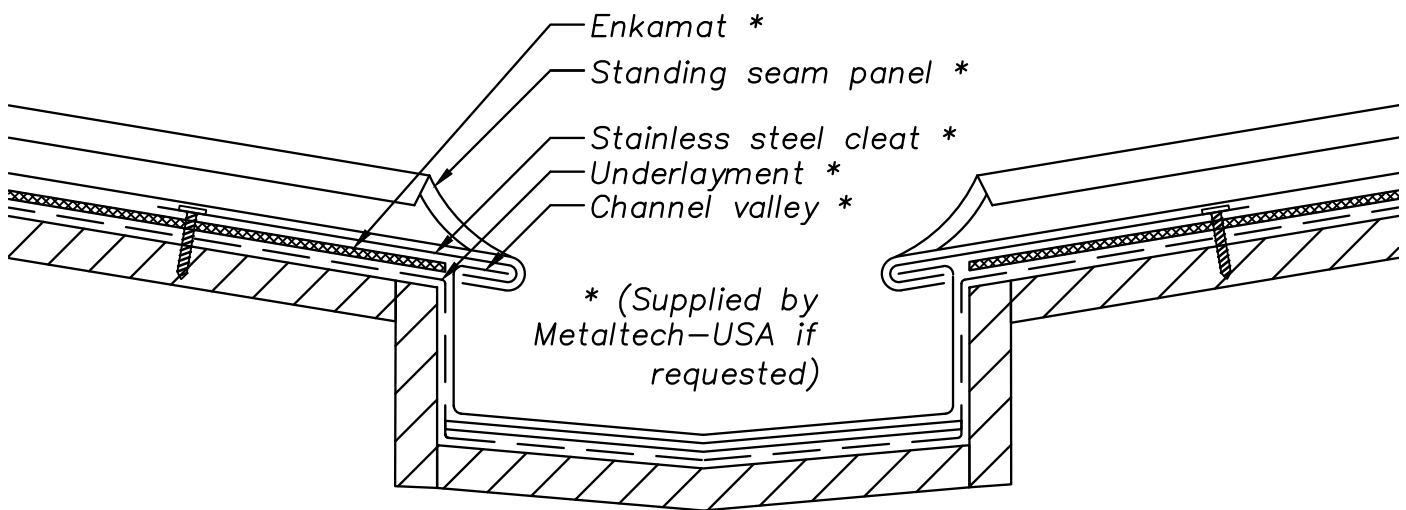

NOTE:
 Information and details are only a baseline for system and installation. Modification to meet project requirement is the responsibility of the designer, architect and contractor. MetalTech-USA project staff are available to assist throughout the design and build process. © 2011 MetalTech-USA. All rights reserved.

UNLESS OTHERWISE SPECIFIED DIMENSIONS ARE IN INCHES	DRAWING NAME: VALLEY DETAIL - OPTION 2		REVISION NO: A	DATED CREATED: 5/24/2015	
	DWG NO: MT_SSRP_1303		CHECKED BY: ESIMONSEN	APPROVED BY: ESIMONSEN	
	PROJECT NAME: VALLEY DETAILS				
	SCALE: NTS	SHEET NO: 3 OF 6	SIZE: A	TOLERANCES: ANGULAR ±1° LINEAR ±0.06	

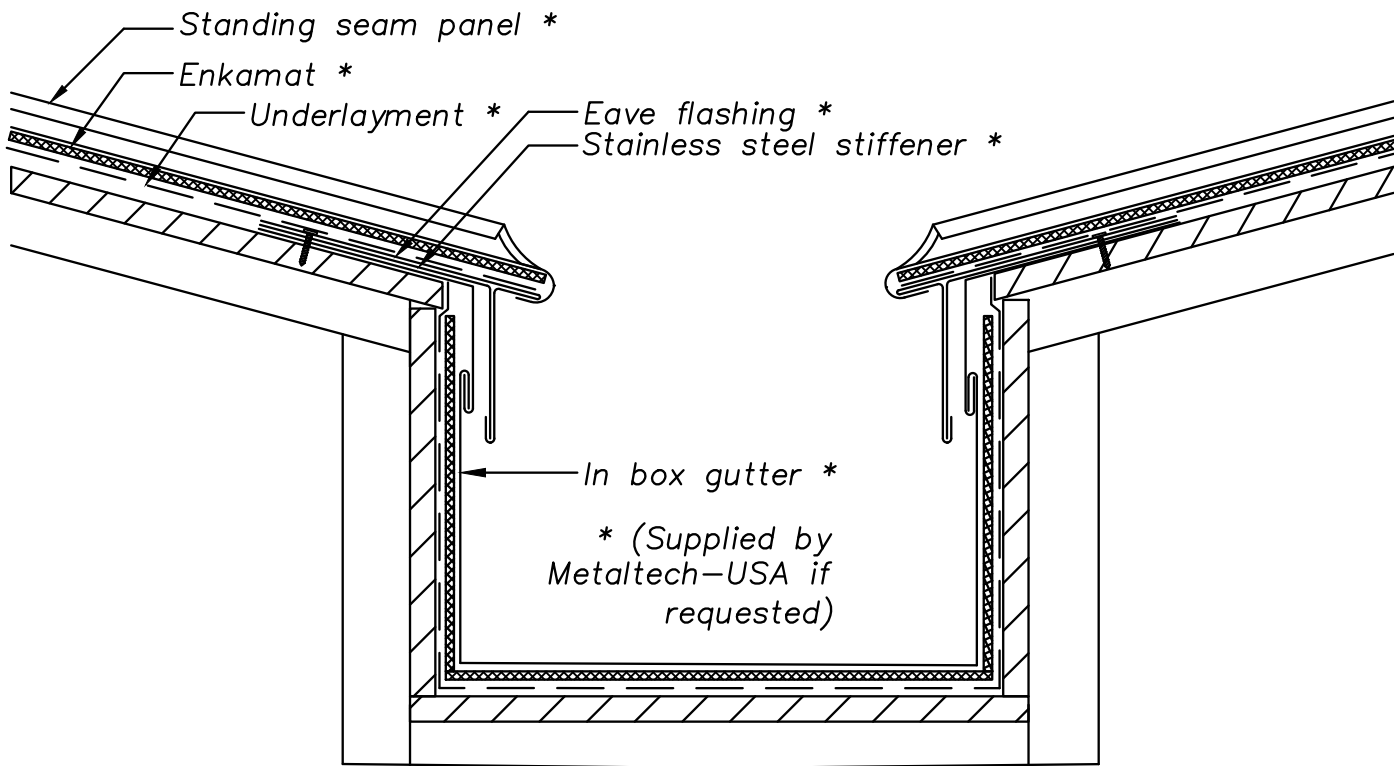

NOTE:

Information and details are only a baseline for system and installation. Modification to meet project requirement is the responsibility of the designer, architect and contractor. MetalTech-USA project staff are available to assist throughout the design and build process. © 2011 MetalTech-USA. All rights reserved.

<p>UNLESS OTHERWISE SPECIFIED DIMENSIONS ARE IN INCHES</p>	<p>DRAWING NAME: VALLEY DETAIL - OPTION 3</p>		<p>REVISION NO: A</p>	<p>DATED CREATED: 5/24/2015</p>	
	<p>DWG NO: MT_SSRP_1304</p>		<p>CHECKED BY: ESIMONSEN</p>	<p>APPROVED BY: ESIMONSEN</p>	
 <p>METALTECH Global a Forza Group Company DESIGNING STRENGTH</p>	<p>PROJECT NAME: VALLEY DETAILS</p>				
	<p>SCALE: NTS</p>	<p>SHEET NO: 4 OF 6</p>	<p>SIZE: A</p>	<p>TOLERANCES: ANGULAR ±1° LINEAR ±0.06</p>	

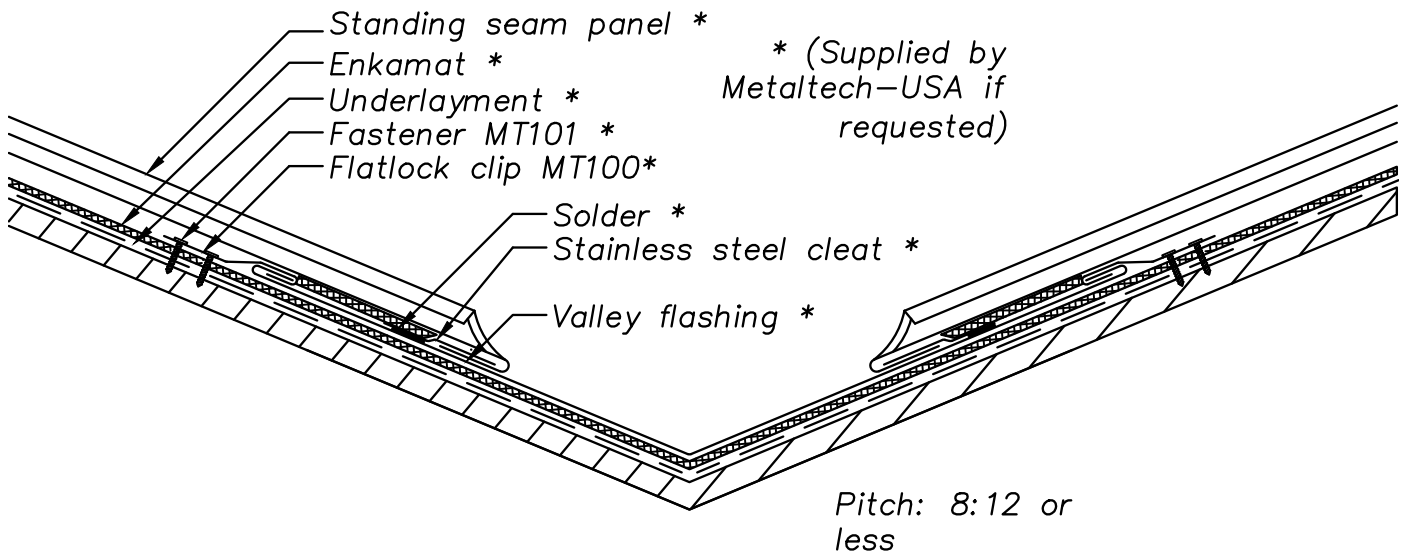

NOTE:
 Information and details are only a baseline for system and installation. Modification to meet project requirement is the responsibility of the designer, architect and contractor. MetalTech-USA project staff are available to assist throughout the design and build process. © 2011 MetalTech-USA. All rights reserved.

 <p> METALTECH Global <small>a Forza Group Company</small> DESIGNING STRENGTH </p>	UNLESS OTHERWISE SPECIFIED DIMENSIONS ARE IN INCHES		DRAWING NAME: VALLEY DETAIL - 8:12 OR LESS	REVISION NO: A	DATED CREATED: 5/24/2015	
			DWG NO: MT_SSRP_1305	CHECKED BY: ESIMONSEN	APPROVED BY: ESIMONSEN	
			PROJECT NAME: VALLEY DETAILS			
	SCALE: NTS	SHEET NO: 5 OF 6	SIZE: A	TOLERANCES: ANGULAR ±1" LINEAR ±0.06		

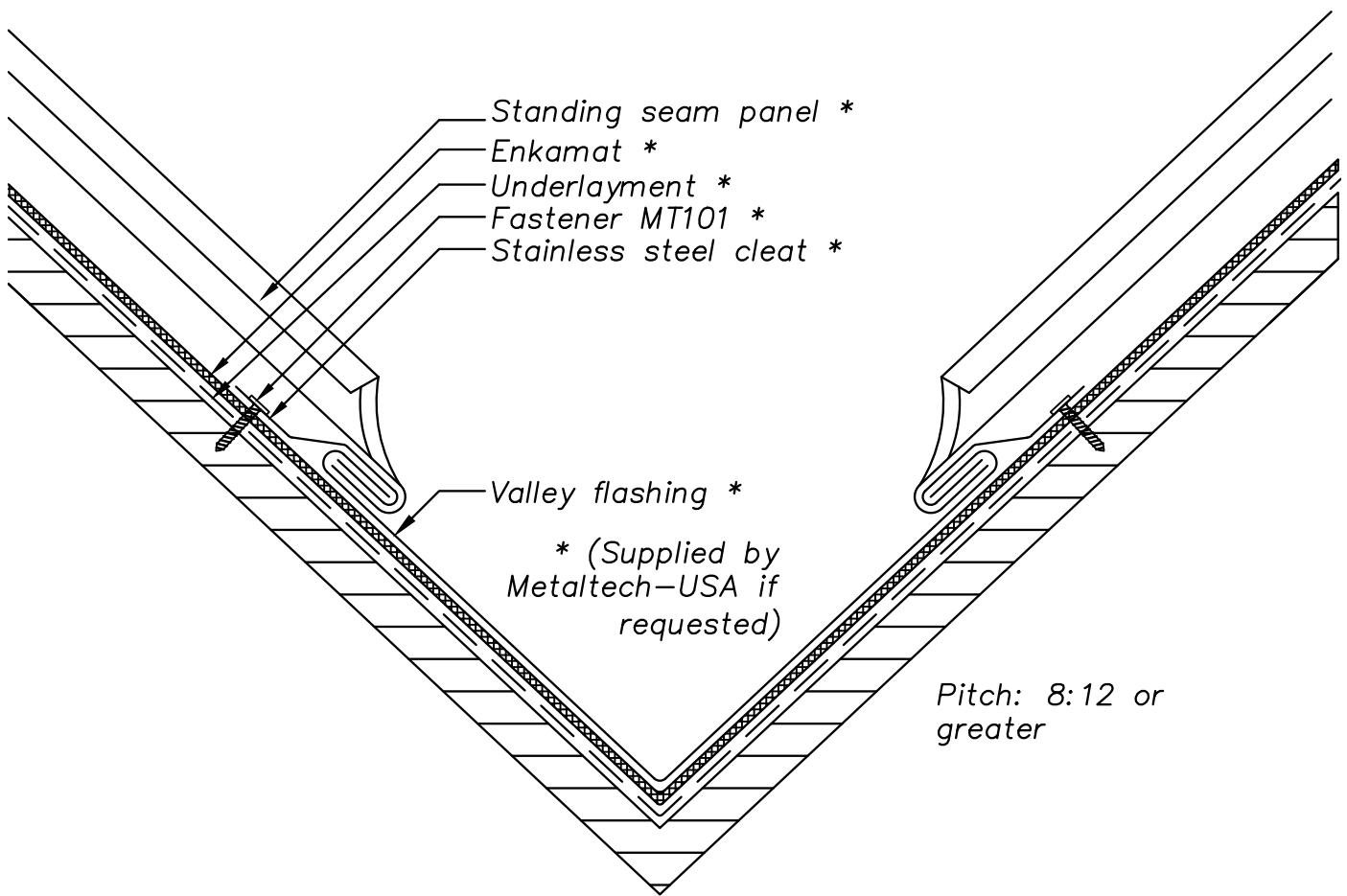

NOTE:
 Information and details are only a baseline for system and installation. Modification to meet project requirement is the responsibility of the designer, architect and contractor. MetalTech-USA project staff are available to assist throughout the design and build process. © 2011 MetalTech-USA. All rights reserved.

 <p> METALTECH Global <small>a Forza Group Company</small> DESIGNING STRENGTH </p>	UNLESS OTHERWISE SPECIFIED DIMENSIONS ARE IN INCHES		DRAWING NAME: VALLEY DETAIL - 8:12 OR GREATER	REVISION NO: A	DATED CREATED: 5/24/2015
	DWG NO: MT_SSRP_1306		CHECKED BY: ESIMONSEN	APPROVED BY: ESIMONSEN	
	PROJECT NAME: VALLEY DETAILS				
	SCALE: NTS	SHEET NO: 6 OF 6	SIZE: A	TOLERANCES: ANGULAR ±1° LINEAR ±0.06	

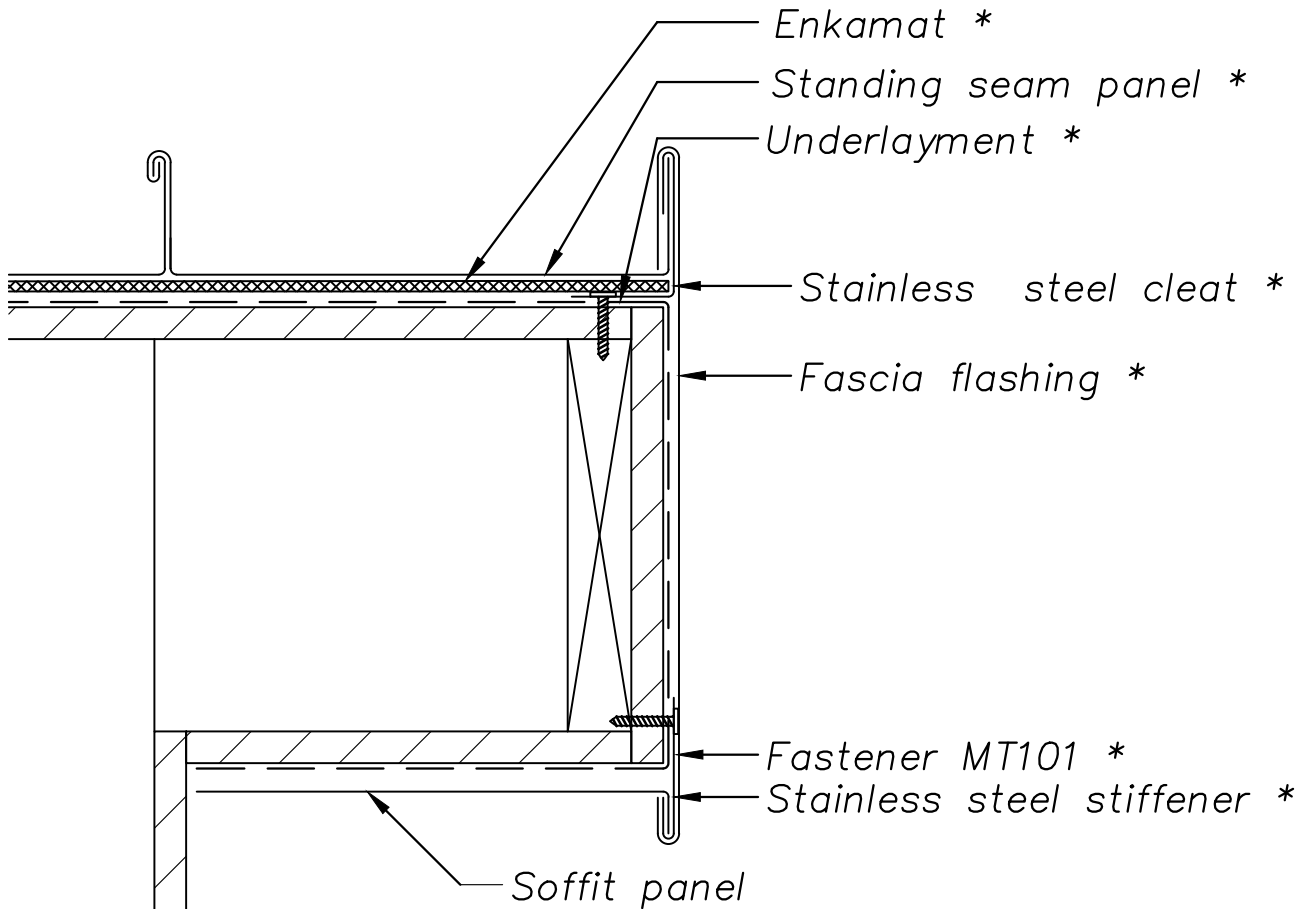

* (Supplied by Metaltech-USA if requested)

NOTE:

Information and details are only a baseline for system and installation. Modification to meet project requirement is the responsibility of the designer, architect and contractor. MetalTech-USA project staff are available to assist throughout the design and build process. © 2011 MetalTech-USA. All rights reserved.

UNLESS OTHERWISE SPECIFIED DIMENSIONS ARE IN INCHES

DRAWING NAME:
RAKE EDGE - OPTION 1

REVISION NO:
A

DATED CREATED:
5/27/2015



DWG NO:
MT_SSRP_1401

CHECKED BY:
ESIMONSEN

APPROVED BY:
ESIMONSEN

PROJECT NAME:
RAKE DETAILS

SCALE:
NTS

SHEET NO:
1 OF 8

SIZE:
A

TOLERANCES:
ANGULAR ±1° LINEAR ±0.06

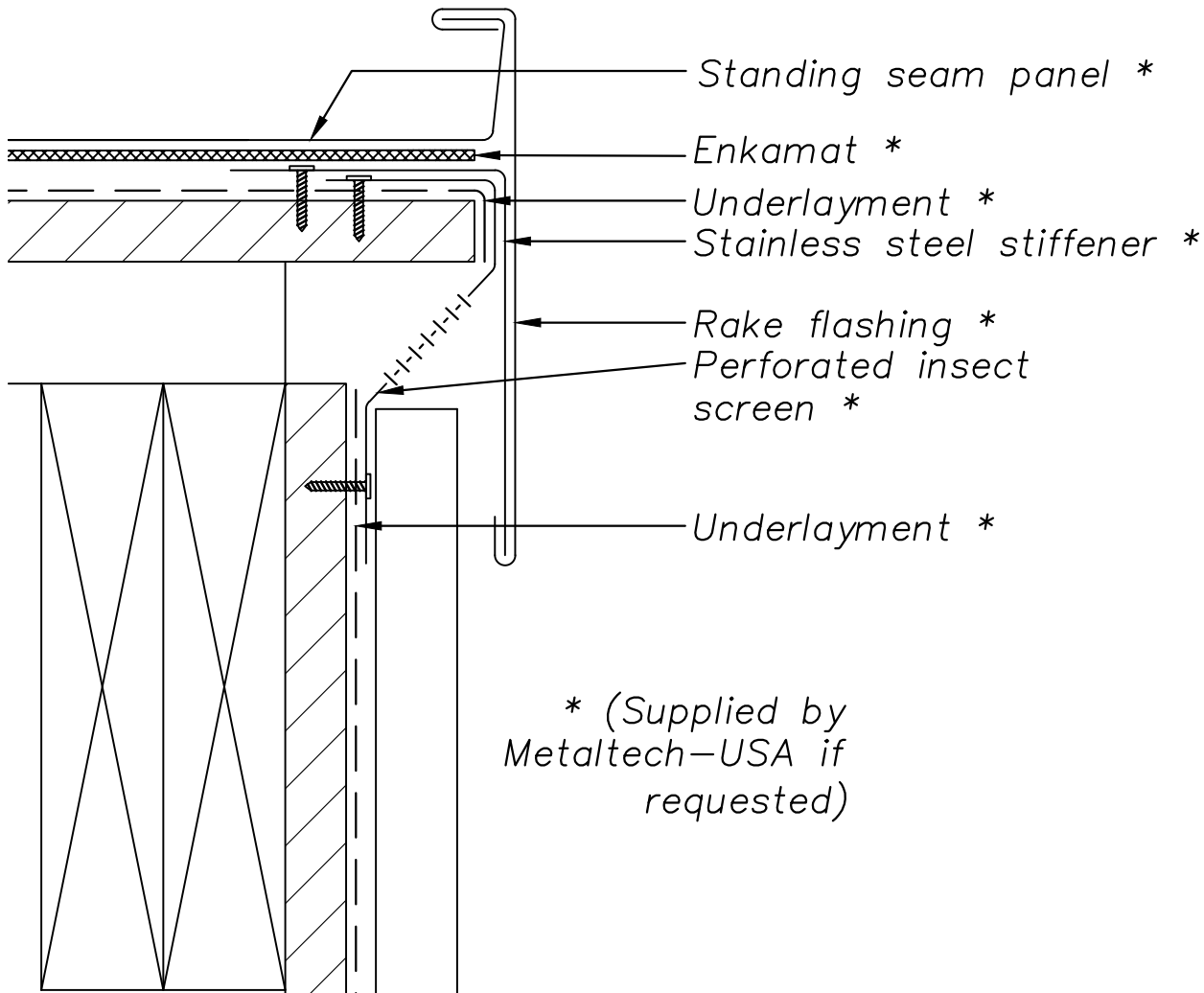

NOTE: Information and details are only a baseline for system and installation. Modification to meet project requirement is the responsibility of the designer, architect and contractor. MetalTech-USA project staff are available to assist throughout the design and build process. © 2011 MetalTech-USA. All rights reserved.

UNLESS OTHERWISE SPECIFIED
DIMENSIONS ARE IN INCHES

DRAWING NAME:
RAKE EDGE - OPTION 2

REVISION NO:
A

DATED CREATED:
5/27/2015

DWG NO:
MT_SSRP_1402

CHECKED BY:
ESIMONSEN

APPROVED BY:
ESIMONSEN

PROJECT NAME:
RAKE DETAILS

SCALE:
NTS

SHEET NO:
2 OF 8

SIZE:
A

TOLERANCES:
ANGULAR $\pm 1^\circ$ LINEAR ± 0.06



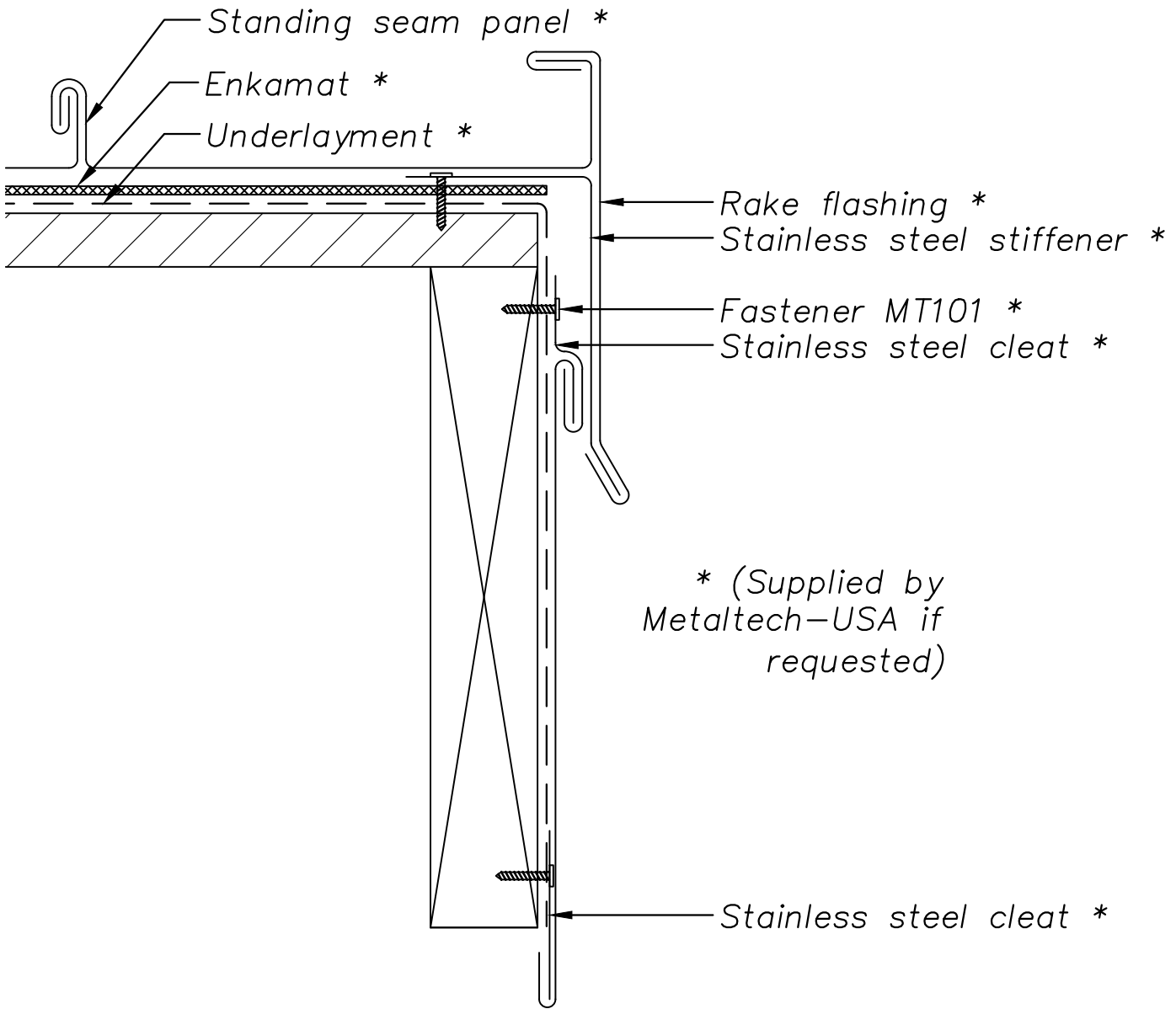

NOTE:
 Information and details are only a baseline for system and installation. Modification to meet project requirement is the responsibility of the designer, architect and contractor. MetalTech-USA project staff are available to assist throughout the design and build process. © 2011 MetalTech-USA. All rights reserved.

UNLESS OTHERWISE SPECIFIED DIMENSIONS ARE IN INCHES	DRAWING NAME: RAKE EDGE - OPTION 3		REVISION NO: A	DATED CREATED: 5/27/2015
	DWG NO: MT_SSRP_1403		CHECKED BY: ESIMONSEN	APPROVED BY: ESIMONSEN
	PROJECT NAME: RAKE DETAILS			
	SCALE: NTS	SHEET NO: 3 OF 8	SIZE: A	TOLERANCES: ANGULAR $\pm 1^\circ$ LINEAR ± 0.06

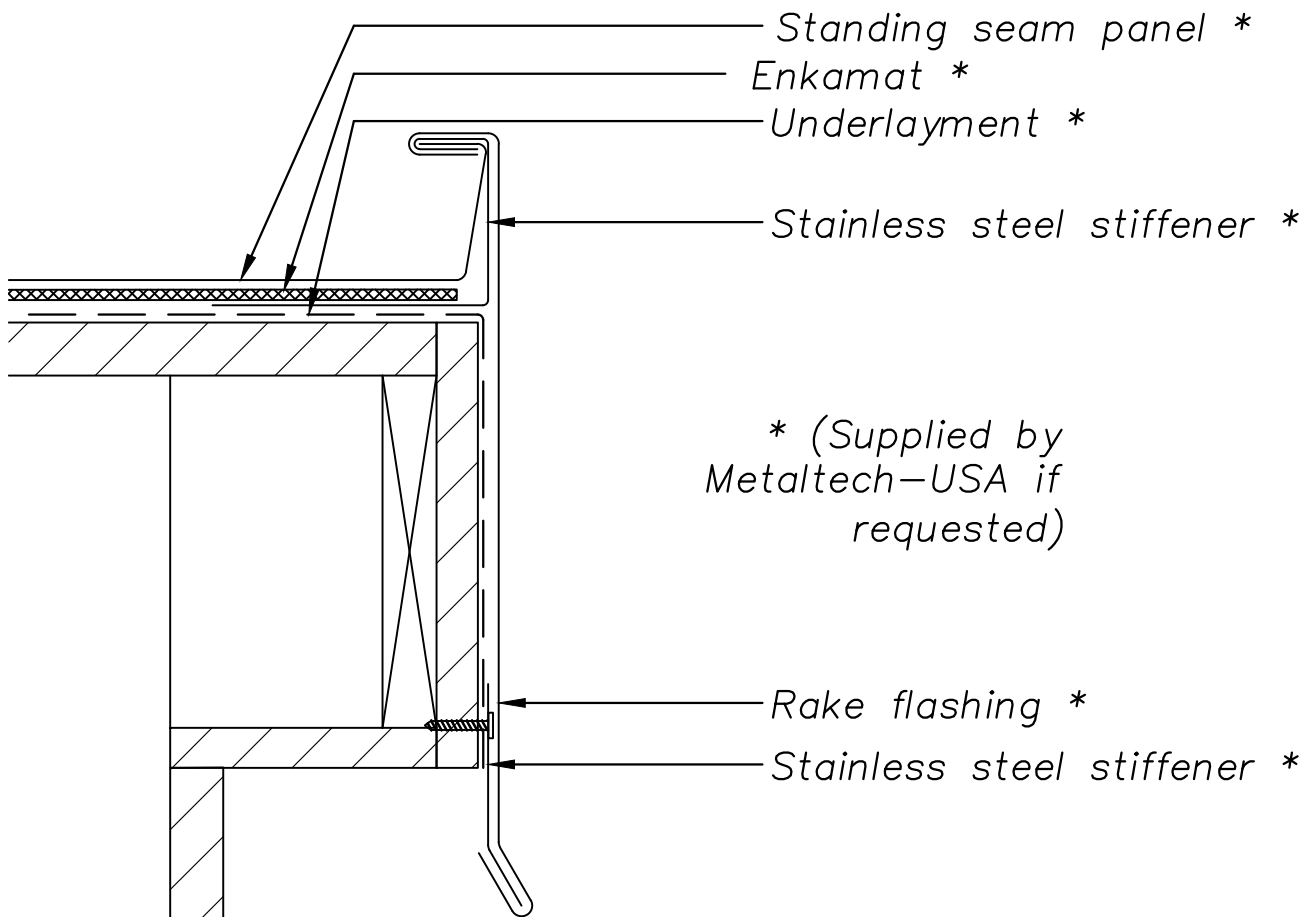

NOTE:

Information and details are only a baseline for system and installation. Modification to meet project requirement is the responsibility of the designer, architect and contractor. MetalTech-USA project staff are available to assist throughout the design and build process. © 2011 MetalTech-USA. All rights reserved.

UNLESS OTHERWISE SPECIFIED
DIMENSIONS ARE IN INCHES

DRAWING NAME:
RAKE EDGE - OPTION 4

REVISION NO:
A

DATED CREATED:
5/27/2015



DWG NO:
MT_SSRP_1404

CHECKED BY:
ESIMONSEN

APPROVED BY:
ESIMONSEN

PROJECT NAME:
RAKE DETAILS

SCALE:
NTS

SHEET NO:
4 OF 8

SIZE:
A

TOLERANCES:
ANGULAR $\pm 1^\circ$ LINEAR ± 0.06

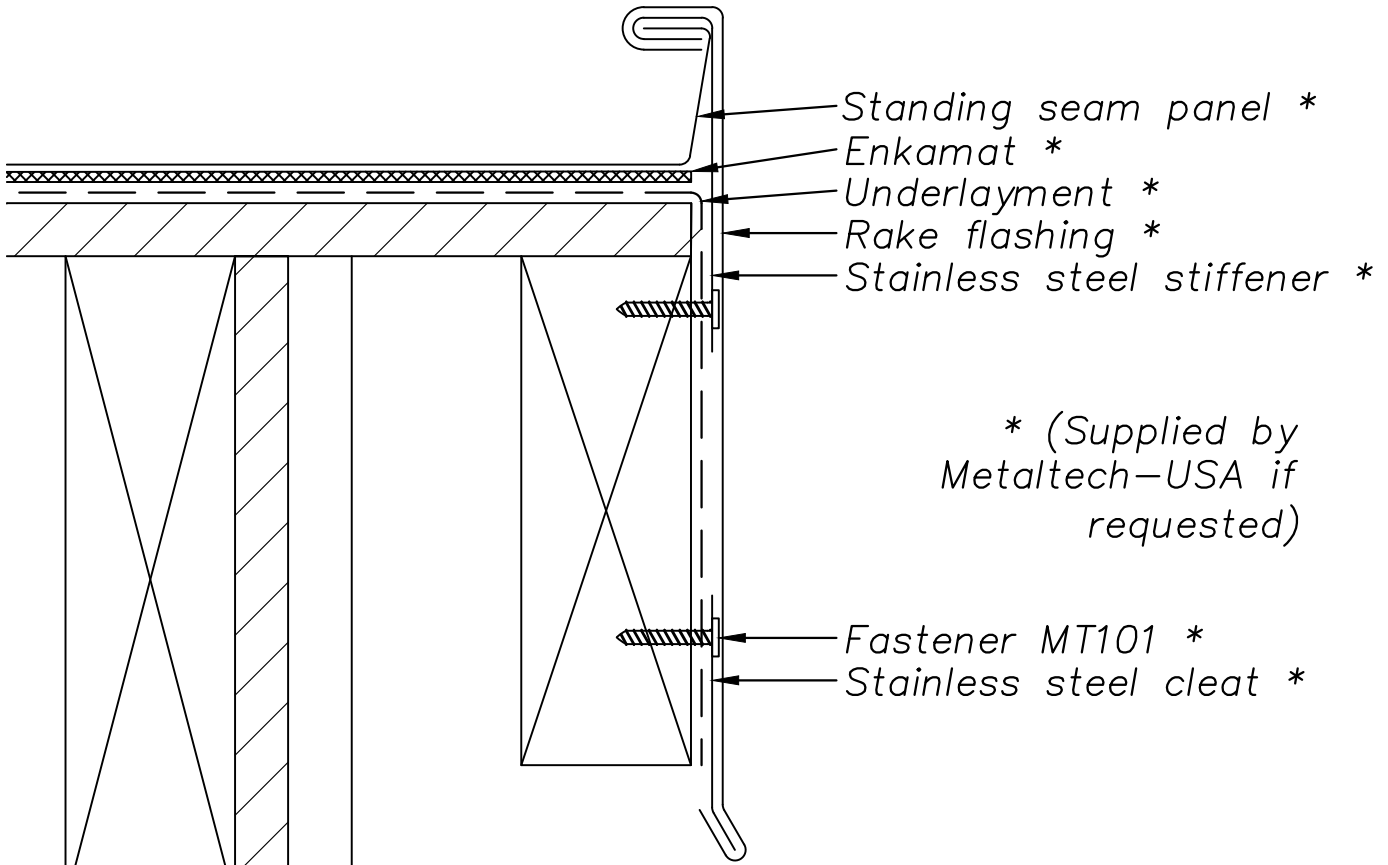

NOTE:

Information and details are only a baseline for system and installation. Modification to meet project requirement is the responsibility of the designer, architect and contractor. MetalTech-USA project staff are available to assist throughout the design and build process. © 2011 MetalTech-USA. All rights reserved.

UNLESS OTHERWISE SPECIFIED
DIMENSIONS ARE IN INCHES

DRAWING NAME:
RAKE EDGE - OPTION 5

REVISION NO:
A

DATED CREATED:
5/27/2015

DWG NO:
MT_SSRP_1405

CHECKED BY:
ESIMONSEN

APPROVED BY:
ESIMONSEN

PROJECT NAME:
RAKE DETAILS

SCALE:
NTS

SHEET NO:
5 OF 8

SIZE:
A

TOLERANCES:
ANGULAR $\pm 1^\circ$ LINEAR ± 0.06



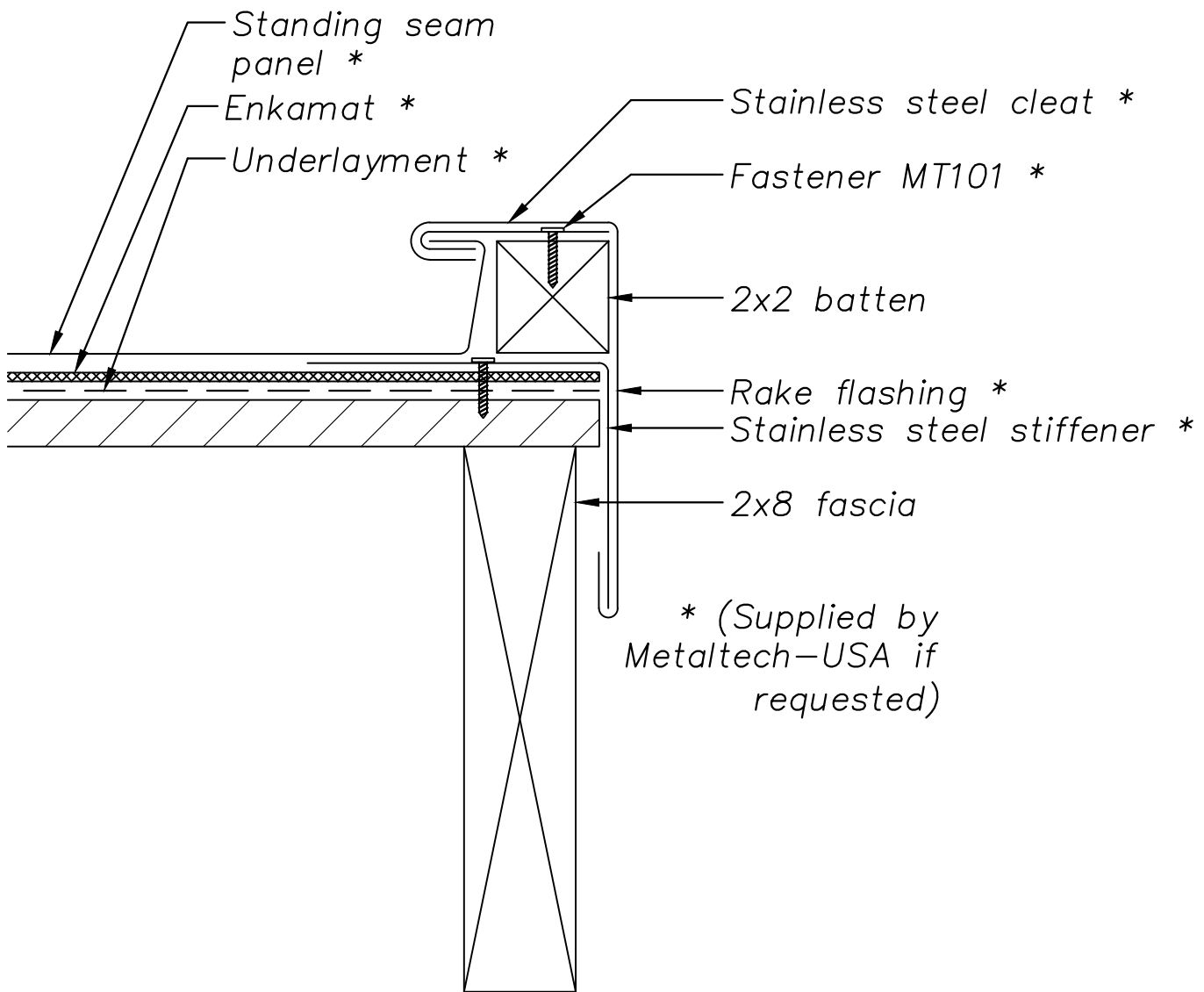

NOTE:
 Information and details are only a baseline for system and installation. Modification to meet project requirement is the responsibility of the designer, architect and contractor. MetalTech-USA project staff are available to assist throughout the design and build process. © 2011 MetalTech-USA. All rights reserved.

UNLESS OTHERWISE SPECIFIED DIMENSIONS ARE IN INCHES	DRAWING NAME: RAKE EDGE - OPTION 6		REVISION NO: A	DATED CREATED: 5/27/2015
	DWG NO: MT_SSRP_1406		CHECKED BY: ESIMONSEN	APPROVED BY: ESIMONSEN
				
PROJECT NAME: RAKE DETAILS				
SCALE: NTS	SHEET NO: 6 OF 8	SIZE: A	TOLERANCES: ANGULAR $\pm 1^\circ$ LINEAR ± 0.06	

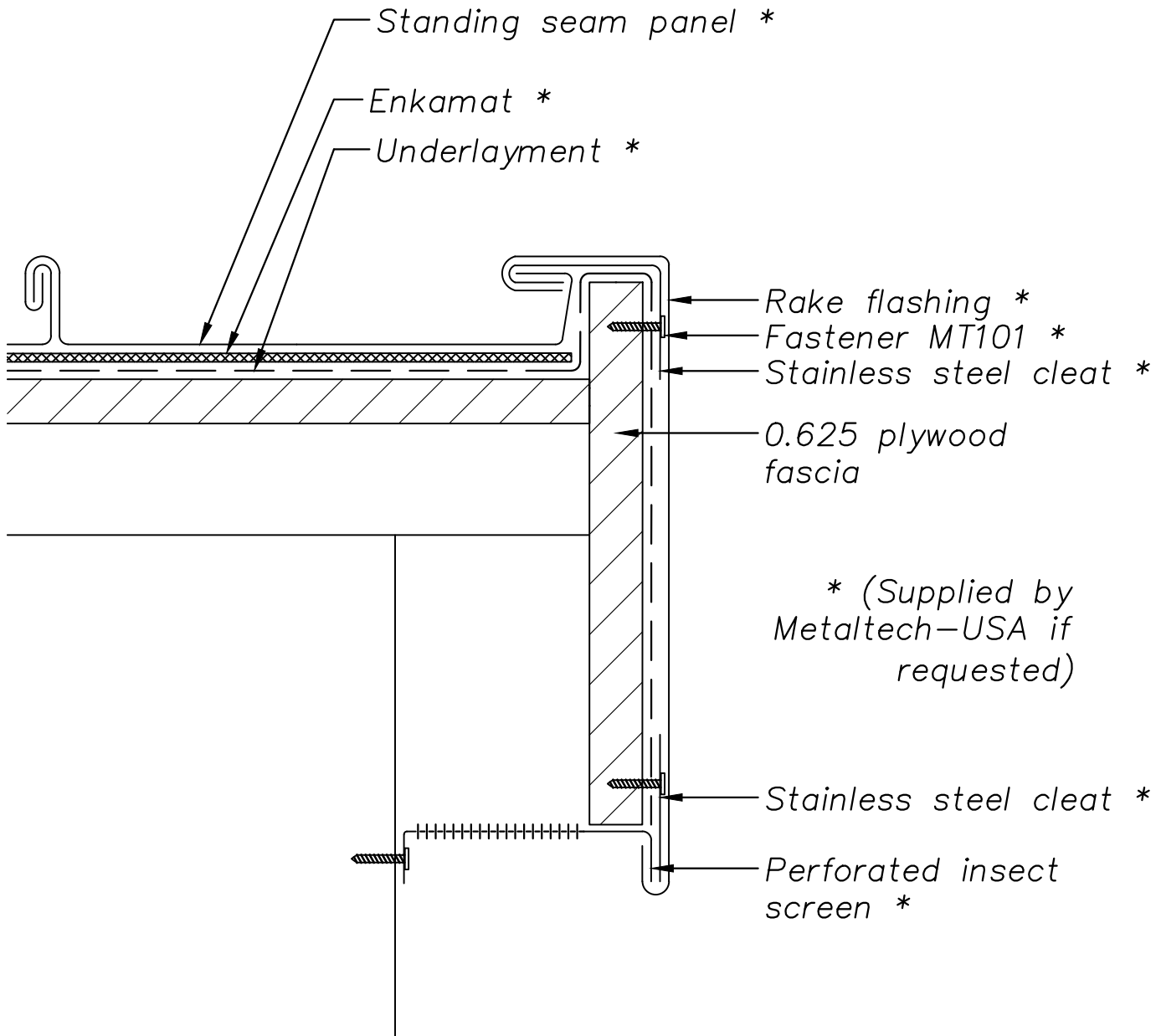

NOTE:
 Information and details are only a baseline for system and installation. Modification to meet project requirement is the responsibility of the designer, architect and contractor. MetalTech-USA project staff are available to assist throughout the design and build process. © 2011 MetalTech-USA. All rights reserved.

UNLESS OTHERWISE SPECIFIED DIMENSIONS ARE IN INCHES	DRAWING NAME: RAKE EDGE - OPTION 7		REVISION NO: A	DATED CREATED: 5/27/2015
	DWG NO: MT_SSRP_1407		CHECKED BY: ESIMONSEN	APPROVED BY: ESIMONSEN
				
PROJECT NAME: RAKE DETAILS				
SCALE: NTS	SHEET NO: 7 OF 8	SIZE: A	TOLERANCES: ANGULAR $\pm 1^\circ$ LINEAR ± 0.06	

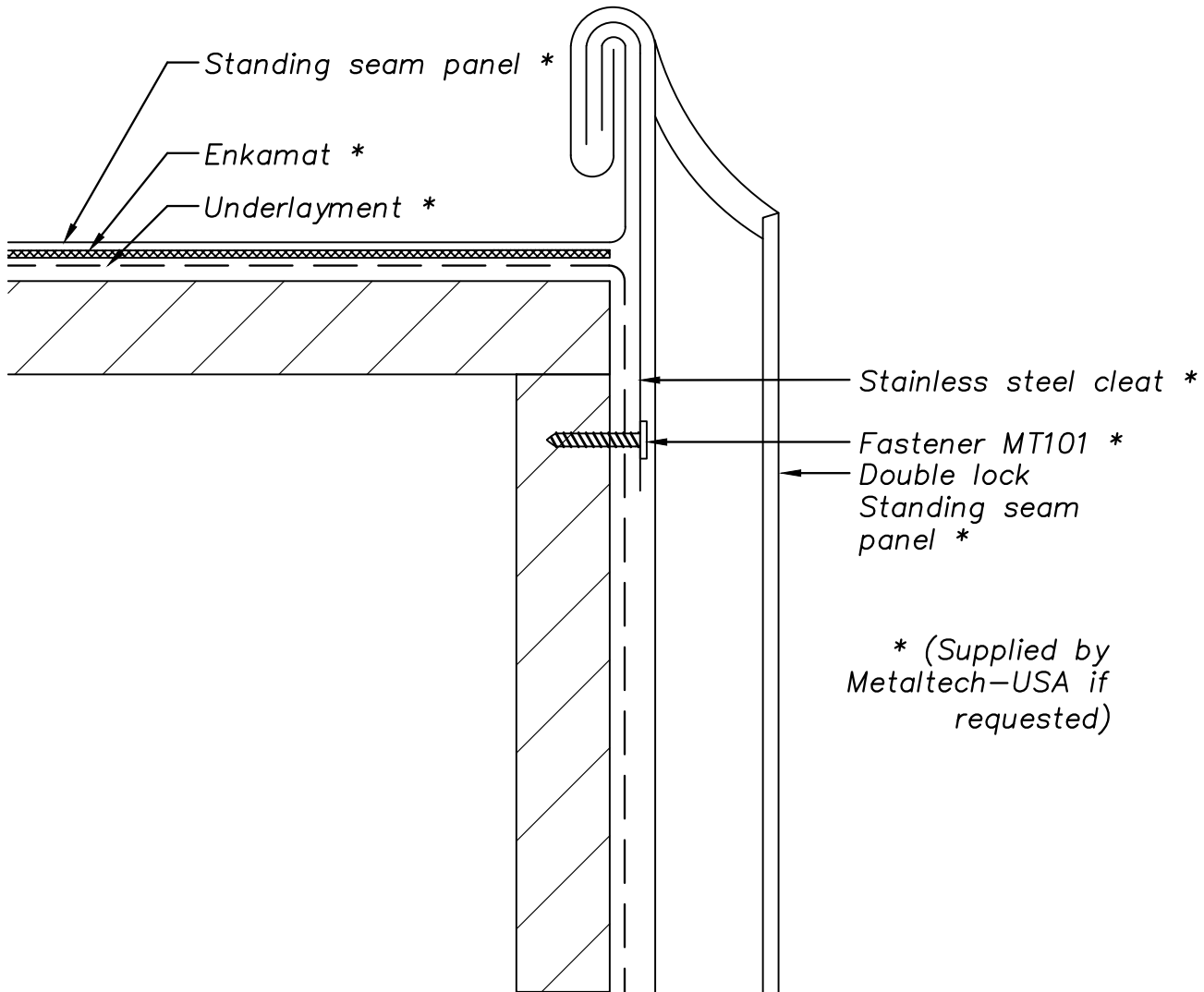

NOTE:

Information and details are only a baseline for system and installation. Modification to meet project requirement is the responsibility of the designer, architect and contractor. MetalTech-USA project staff are available to assist throughout the design and build process. © 2011 MetalTech-USA. All rights reserved.

UNLESS OTHERWISE SPECIFIED DIMENSIONS ARE IN INCHES	DRAWING NAME: RAKE EDGE - OPTION 8		REVISION NO: A	DATED CREATED: 5/27/2015
	DWG NO: MT_SSRP_1408		CHECKED BY: ESIMONSEN	APPROVED BY: ESIMONSEN
	PROJECT NAME: RAKE DETAILS			
	SCALE: NTS	SHEET NO: 8 OF 8	SIZE: A	TOLERANCES: ANGULAR ±1° LINEAR ±0.06

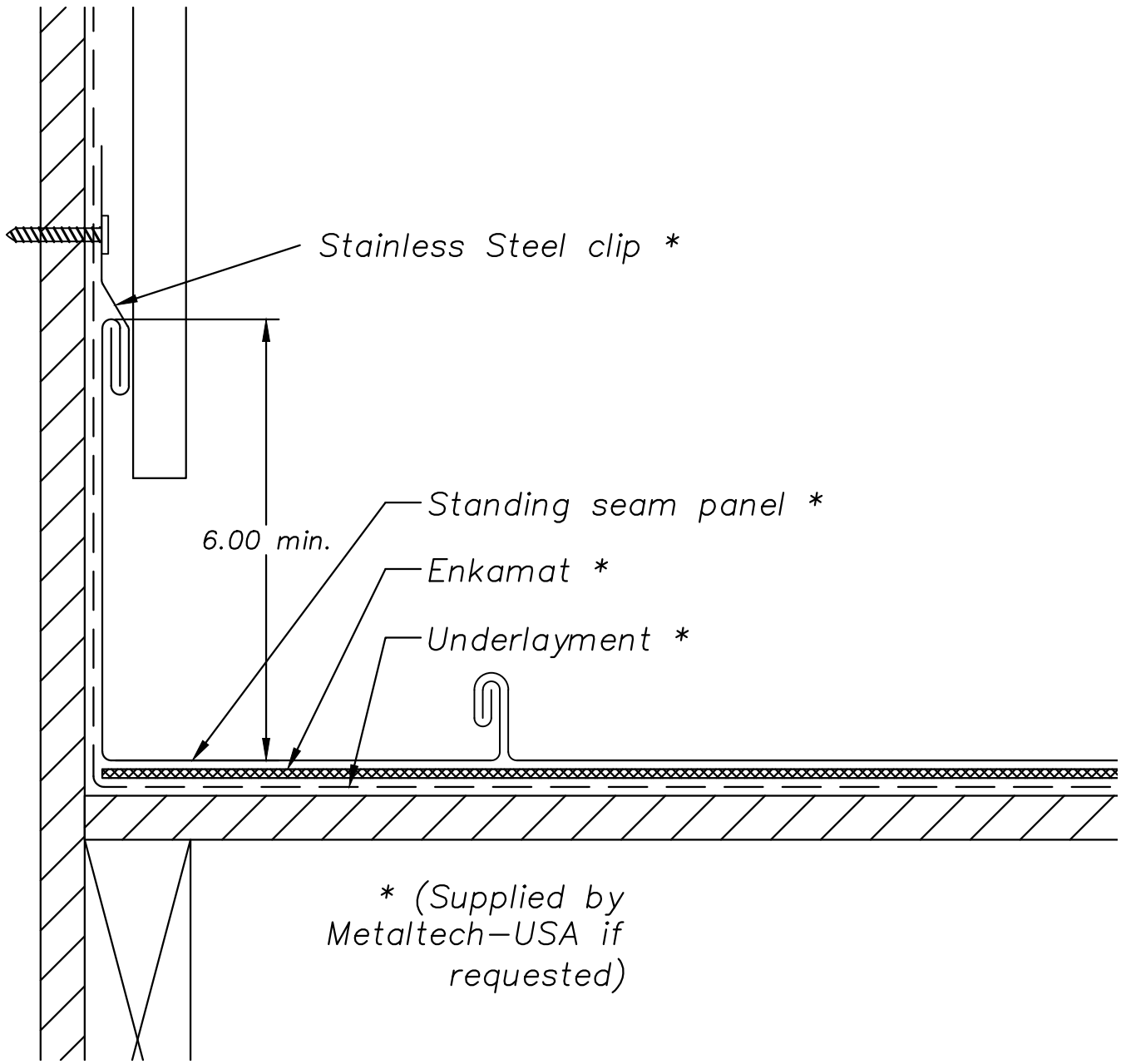

NOTE:
 Information and details are only a baseline for system and installation. Modification to meet project requirement is the responsibility of the designer, architect and contractor. MetalTech-USA project staff are available to assist throughout the design and build process. © 2011 MetalTech-USA. All rights reserved.

UNLESS OTHERWISE SPECIFIED DIMENSIONS ARE IN INCHES	DRAWING NAME: SIDE WALL – OPTION 1		REVISION NO: A	DATED CREATED: 5/28/2015	
	DWG NO: MT_SSRP_1501		CHECKED BY: ESIMONSEN	APPROVED BY: ESIMONSEN	
	PROJECT NAME: WALL DETAILS				
	SCALE: NTS	SHEET NO: 1 OF 16	SIZE: A	TOLERANCES: ANGULAR ±1° LINEAR ±0.06	

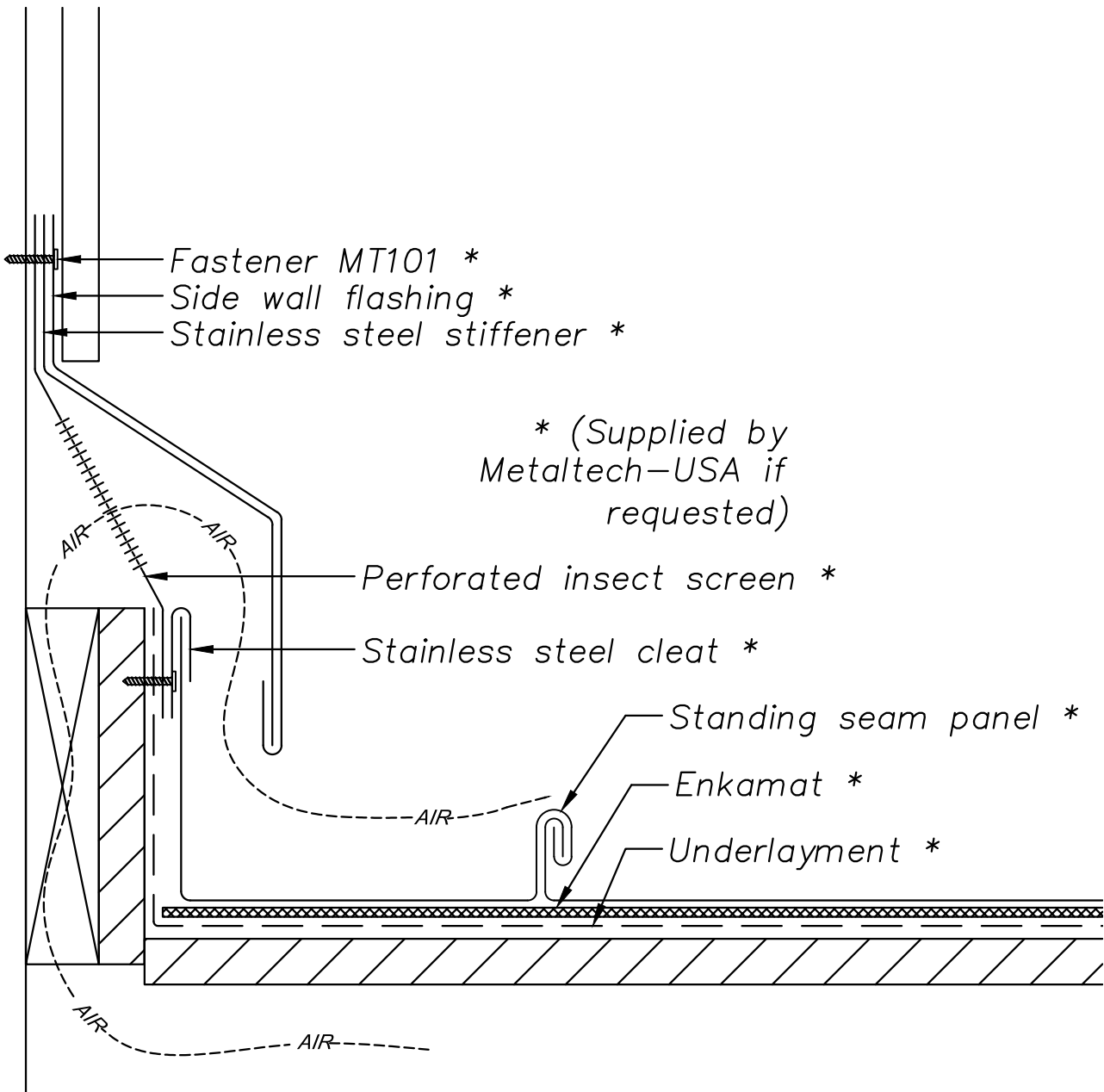

NOTE:
 Information and details are only a baseline for system and installation. Modification to meet project requirement is the responsibility of the designer, architect and contractor. MetalTech-USA project staff are available to assist throughout the design and build process. © 2011 MetalTech-USA. All rights reserved.

UNLESS OTHERWISE SPECIFIED DIMENSIONS ARE IN INCHES	DRAWING NAME: SIDE WALL - OPTION 2		REVISION NO: A	DATED CREATED: 5/28/2015	
	DWG NO: MT_SSRP_1502		CHECKED BY: ESIMONSEN	APPROVED BY: ESIMONSEN	
	PROJECT NAME: WALL DETAILS				
	SCALE: NTS	SHEET NO: 2 OF 16	SIZE: A	TOLERANCES: ANGULAR ±1° LINEAR ±0.06	

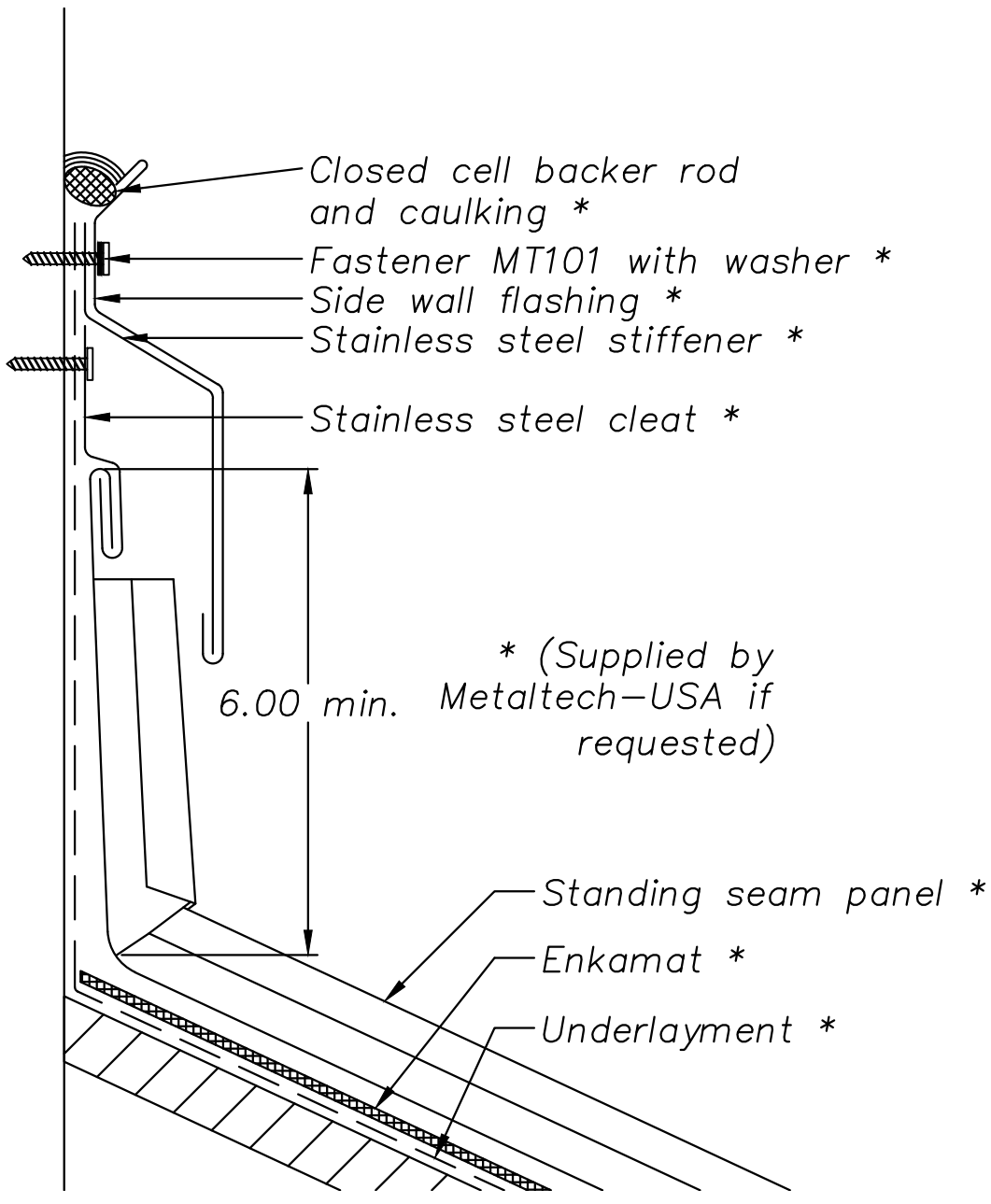

NOTE: Information and details are only a baseline for system and installation. Modification to meet project requirement is the responsibility of the designer, architect and contractor. MetalTech-USA project staff are available to assist throughout the design and build process. © 2011 MetalTech-USA. All rights reserved.

UNLESS OTHERWISE SPECIFIED DIMENSIONS ARE IN INCHES	DRAWING NAME: HEAD WALL - OPTION 1		REVISION NO: A	DATED CREATED: 5/28/2015
	DWG NO: MT_SSRP_1503		CHECKED BY: ESIMONSEN	APPROVED BY: ESIMONSEN
PROJECT NAME: WALL DETAILS				
SCALE: NTS		SHEET NO: 3 OF 16	SIZE: A	TOLERANCES: ANGULAR ±1° LINEAR ±0.06



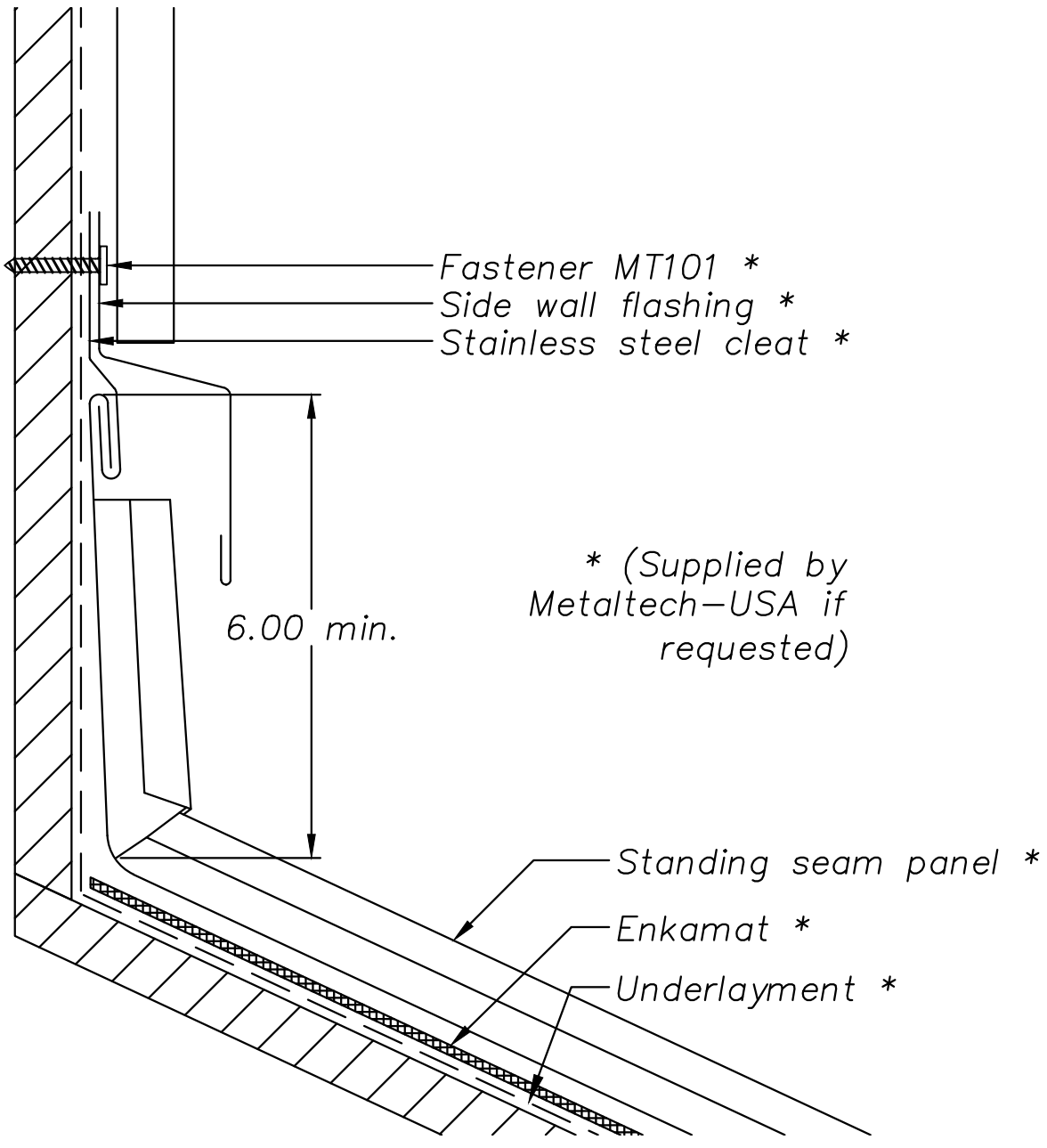

NOTE:
 Information and details are only a baseline for system and installation. Modification to meet project requirement is the responsibility of the designer, architect and contractor. MetalTech-USA project staff are available to assist throughout the design and build process. © 2011 MetalTech-USA. All rights reserved.

 <p>METALTECH Global <small>a Forza Group Company</small> DESIGNING STRENGTH</p>	UNLESS OTHERWISE SPECIFIED DIMENSIONS ARE IN INCHES		DRAWING NAME: HEAD WALL - OPTION 2	REVISION NO: A	DATED CREATED: 5/28/2015	
			DWG NO: MT_SSRP_1504	CHECKED BY: ESIMONSEN	APPROVED BY: ESIMONSEN	
			PROJECT NAME: WALL DETAILS			
	SCALE: NTS	SHEET NO: 4 OF 16	SIZE: A	TOLERANCES: ANGULAR ±1° LINEAR ±0.06		

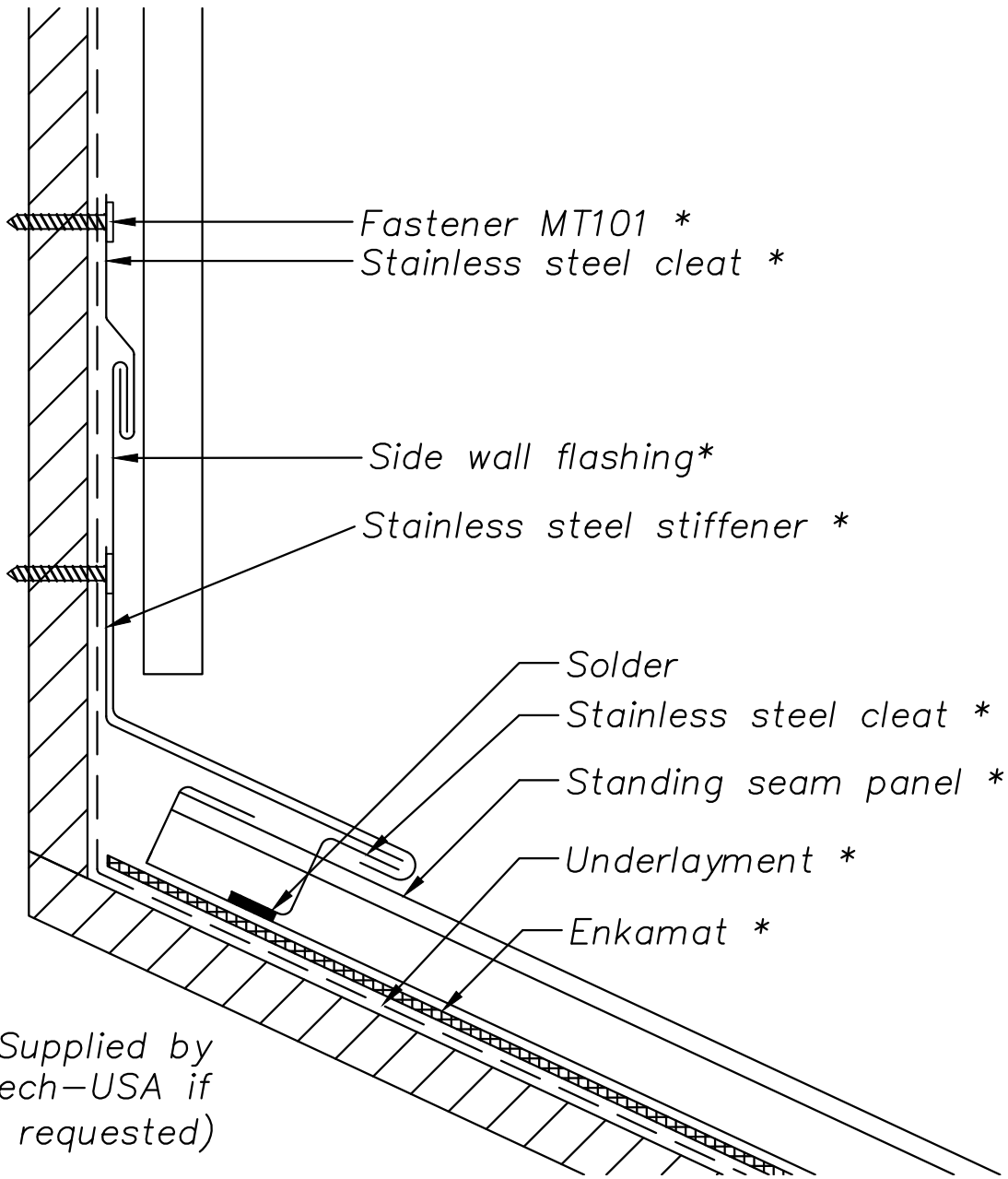

NOTE:
 Information and details are only a baseline for system and installation. Modification to meet project requirement is the responsibility of the designer, architect and contractor. MetalTech-USA project staff are available to assist throughout the design and build process. © 2011 MetalTech-USA. All rights reserved.

UNLESS OTHERWISE SPECIFIED DIMENSIONS ARE IN INCHES	DRAWING NAME: HEAD WALL - OPTION 3		REVISION NO: A	DATED CREATED: 5/28/2015
	DWG NO: MT_SSRP_1505		CHECKED BY: ESIMONSEN	APPROVED BY: ESIMONSEN
PROJECT NAME: WALL DETAILS				
SCALE: NTS	SHEET NO: 5 OF 16	SIZE: A	TOLERANCES: ANGULAR ±1° LINEAR ±0.06	



* (Supplied by
Metaltech-USA if
requested)

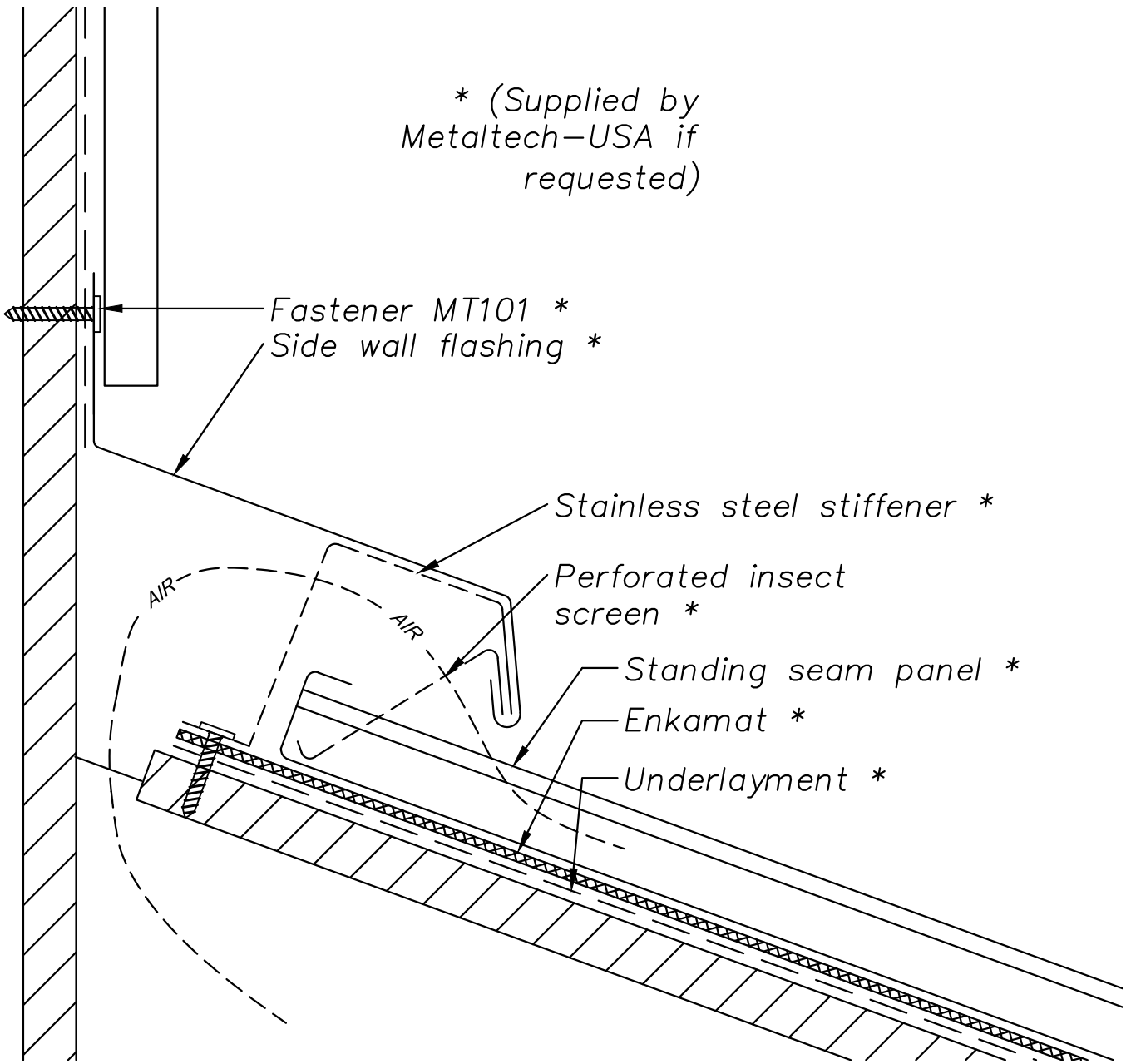

NOTE:
Information and details are only a baseline for system and installation. Modification to meet project requirement is the responsibility of the designer, architect and contractor. MetalTech-USA project staff are available to assist throughout the design and build process. © 2011 MetalTech-USA. All rights reserved.

 <p>METALTECH Global a Forza Group Company DESIGNING STRENGTH</p>	DRAWING NAME: HEAD WALL - OPTION 4		REVISION NO: A	DATED CREATED: 5/28/2015
	DWG NO: MT_SSRP_1506		CHECKED BY: ESIMONSEN	APPROVED BY: ESIMONSEN
PROJECT NAME: WALL DETAILS				
SCALE: NTS	SHEET NO: 6 OF 16	SIZE: A	TOLERANCES: ANGULAR ±1° LINEAR ±0.06	

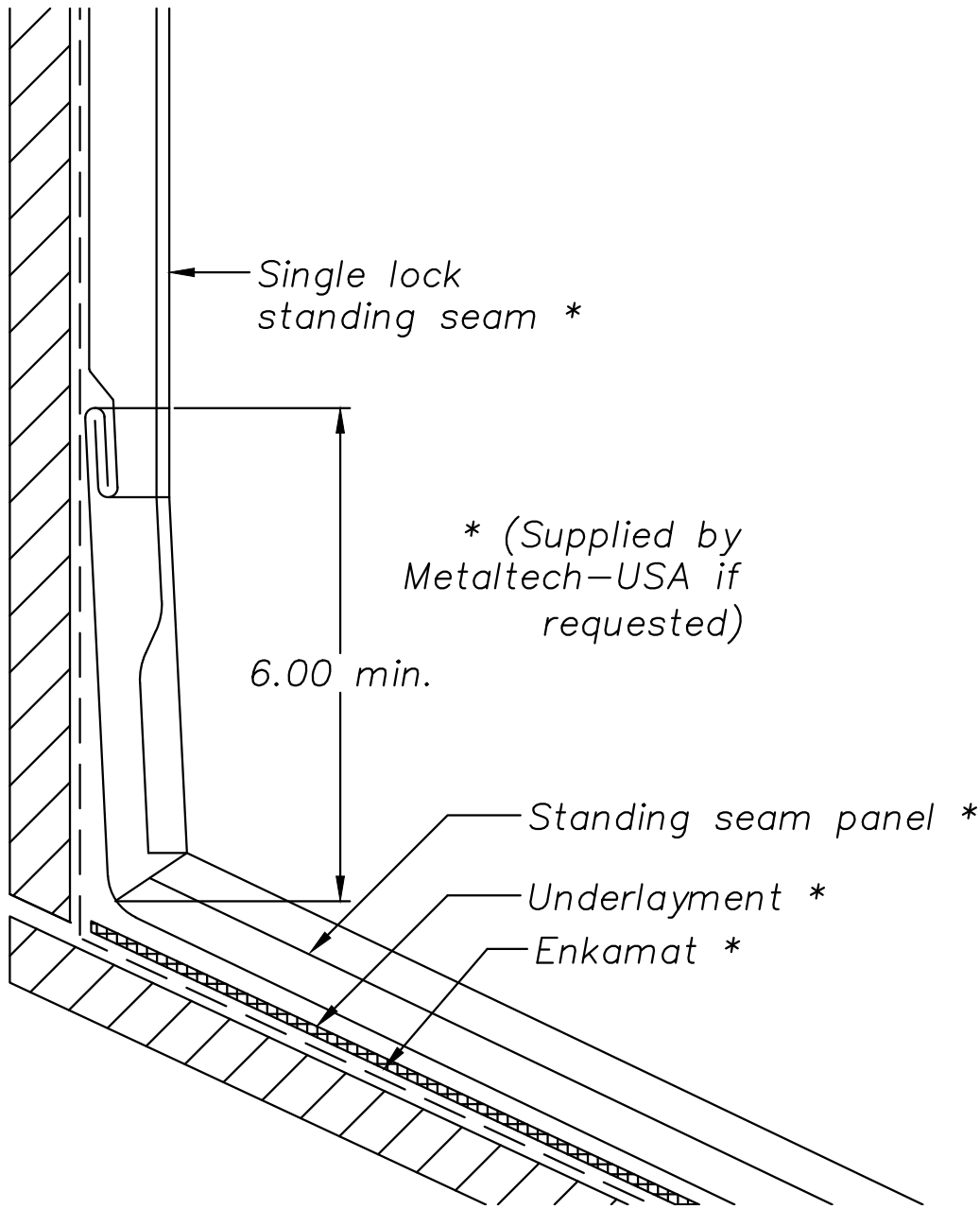

NOTE:
 Information and details are only a baseline for system and installation. Modification to meet project requirement is the responsibility of the designer, architect and contractor. MetalTech-USA project staff are available to assist throughout the design and build process. © 2011 MetalTech-USA. All rights reserved.

 <small>a Forca Group Company</small> DESIGNING STRENGTH	UNLESS OTHERWISE SPECIFIED DIMENSIONS ARE IN INCHES		DRAWING NAME: HEAD WALL - OPTION 5	REVISION NO: A	DATED CREATED: 5/28/2015
			DWG NO: MT_SSRP_1507	CHECKED BY: ESIMONSEN	APPROVED BY: ESIMONSEN
	PROJECT NAME: WALL DETAILS				
	SCALE: NTS	SHEET NO: 7 OF 16	SIZE: A	TOLERANCES: ANGULAR ±1° LINEAR ±0.06	

* (Supplied by Metaltech-USA if requested)

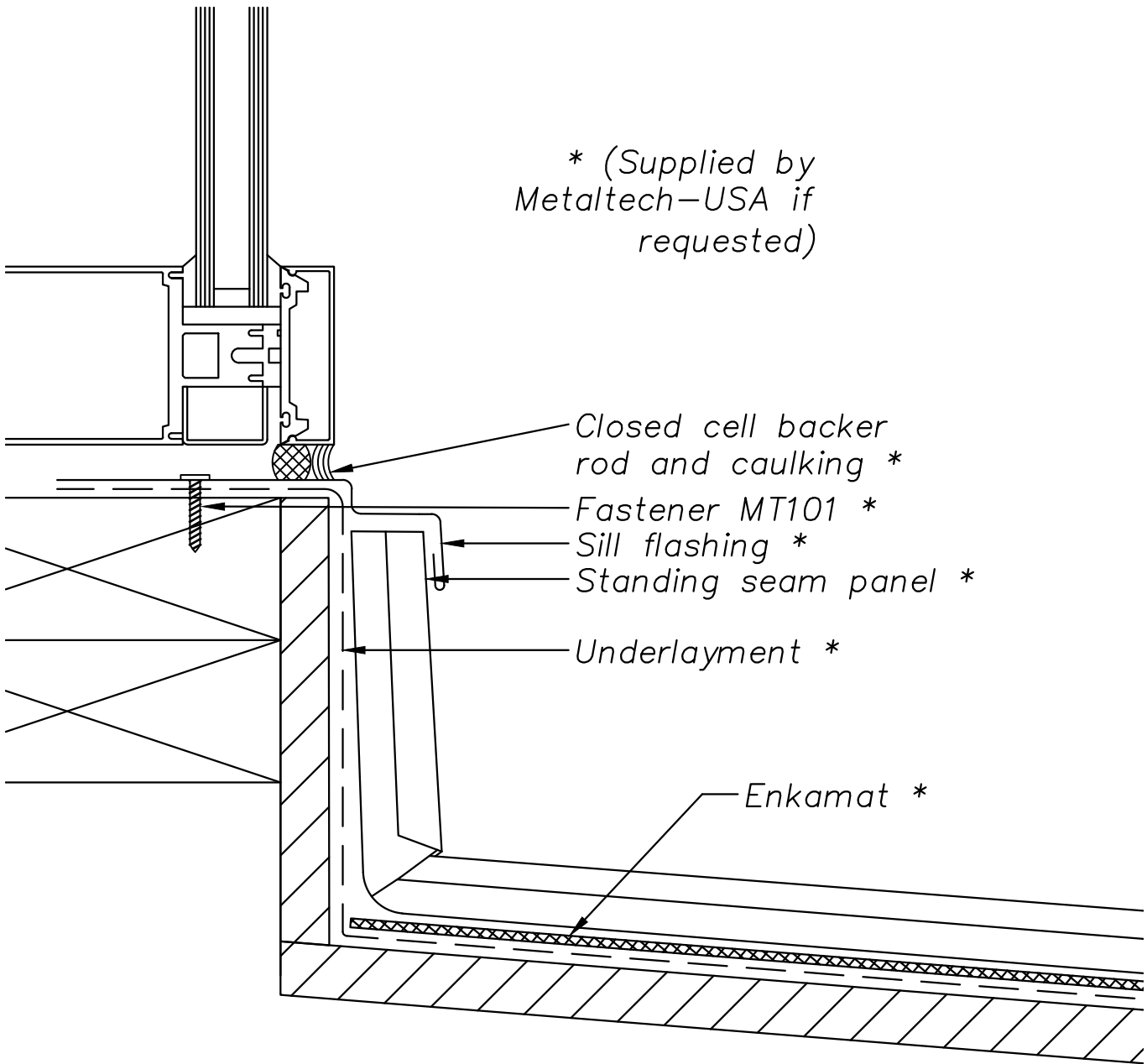

NOTE:
 Information and details are only a baseline for system and installation. Modification to meet project requirement is the responsibility of the designer, architect and contractor. MetalTech-USA project staff are available to assist throughout the design and build process. © 2011 MetalTech-USA. All rights reserved.

	DRAWING NAME: WALL TO SILL TRANSITION – OPTION 1		REVISION NO: A	DATED CREATED: 5/28/2015
	DWG NO: MT_SSRP_1508		CHECKED BY: ESIMONSEN	APPROVED BY: ESIMONSEN
	PROJECT NAME: WALL DETAILS			
	SCALE: NTS	SHEET NO: 8 OF 16	SIZE: A	TOLERANCES: ANGULAR ±1° LINEAR ±0.06

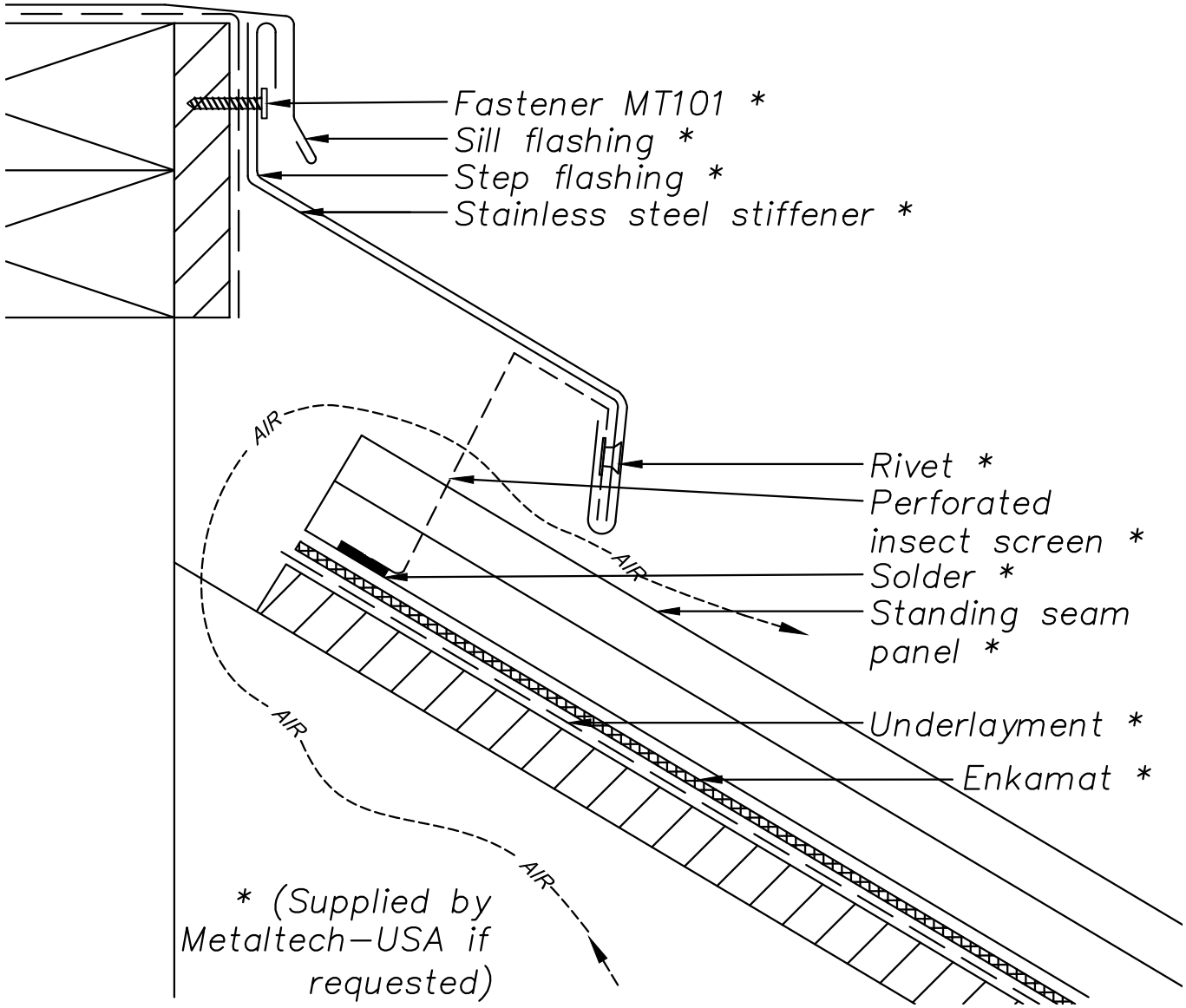
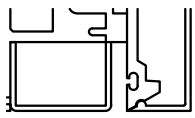

NOTE:
 Information and details are only a baseline for system and installation. Modification to meet project requirement is the responsibility of the designer, architect and contractor. MetalTech-USA project staff are available to assist throughout the design and build process. © 2011 MetalTech-USA. All rights reserved.

UNLESS OTHERWISE SPECIFIED DIMENSIONS ARE IN INCHES	DRAWING NAME: WALL TO SILL TRANSITION – OPTION 2		REVISION NO: A	DATED CREATED: 5/28/2015
	DWG NO: MT_SSRP_1509		CHECKED BY: ESIMONSEN	APPROVED BY: ESIMONSEN
PROJECT NAME: WALL DETAILS				
SCALE: NTS	SHEET NO: 9 OF 16	SIZE: A	TOLERANCES: ANGULAR ±1° LINEAR ±0.06	



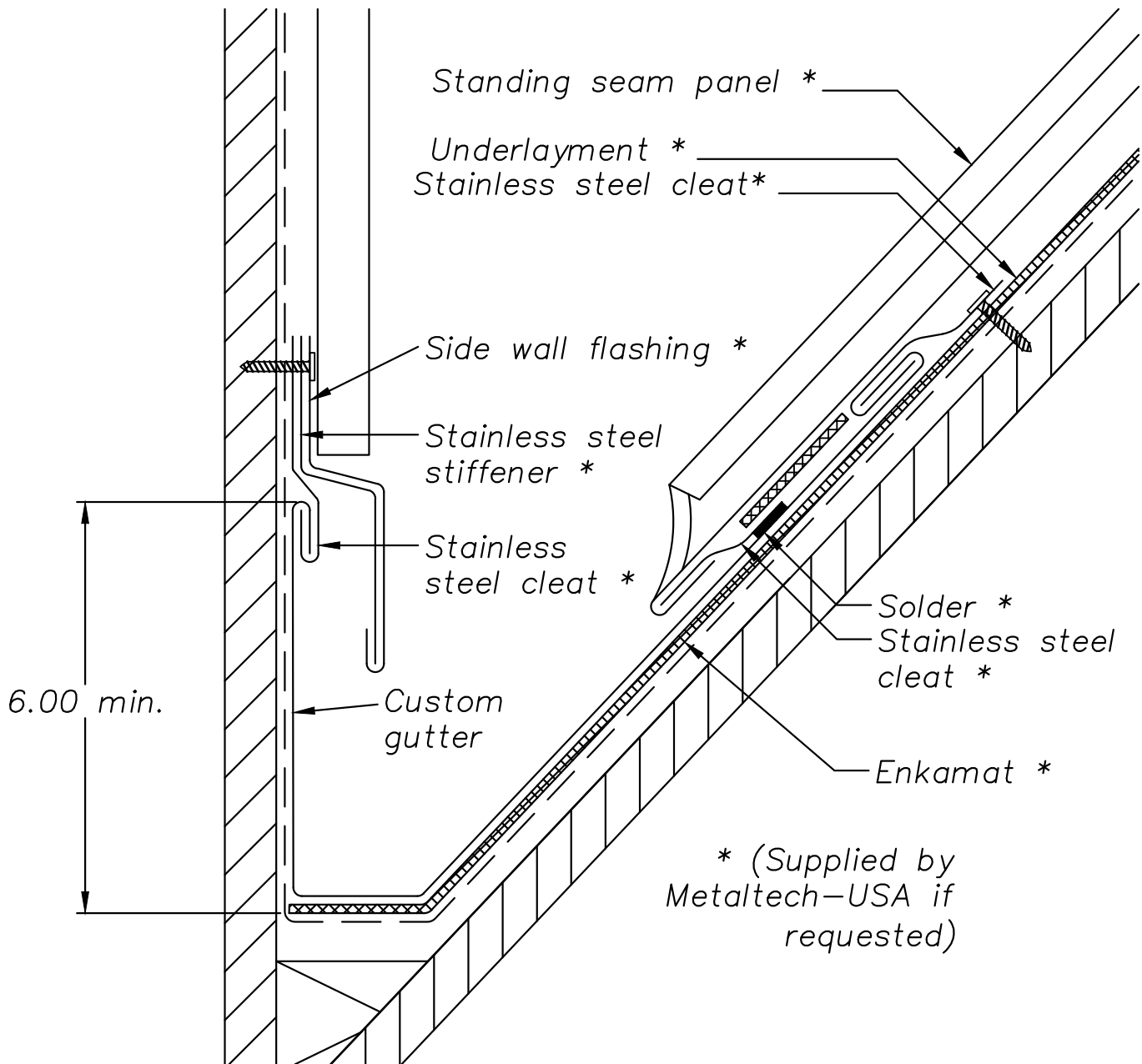

NOTE:
 Information and details are only a baseline for system and installation. Modification to meet project requirement is the responsibility of the designer, architect and contractor. MetalTech-USA project staff are available to assist throughout the design and build process. © 2011 MetalTech-USA. All rights reserved.

UNLESS OTHERWISE SPECIFIED DIMENSIONS ARE IN INCHES	DRAWING NAME: END WALL CRICKET OPTION		REVISION NO: A	DATED CREATED: 5/28/2015
	DWG NO: MT_SSRP_1510		CHECKED BY: ESIMONSEN	APPROVED BY: ESIMONSEN
				
PROJECT NAME: WALL DETAILS				
SCALE: NTS	SHEET NO: 10 OF 16	SIZE: A	TOLERANCES: ANGULAR $\pm 1^\circ$ LINEAR ± 0.06	

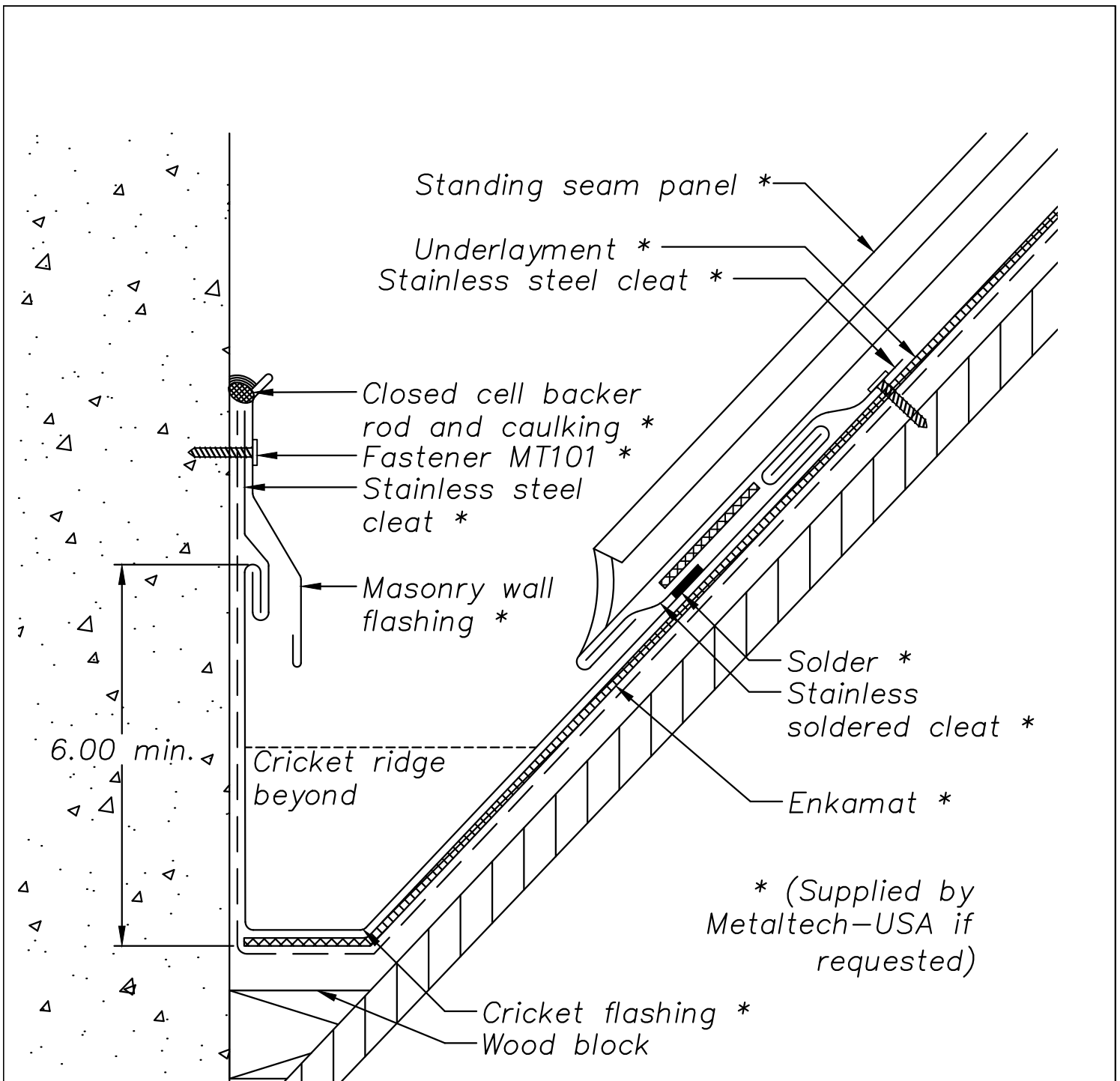

NOTE:
 Information and details are only a baseline for system and installation. Modification to meet project requirement is the responsibility of the designer, architect and contractor. MetalTech-USA project staff are available to assist throughout the design and build process. © 2011 MetalTech-USA. All rights reserved.

UNLESS OTHERWISE SPECIFIED DIMENSIONS ARE IN INCHES	DRAWING NAME: MASONRY WALL CRICKET OPTION		REVISION NO: A	DATED CREATED: 5/28/2015
	DWG NO: MT_SSRP_1511		CHECKED BY: ESIMONSEN	APPROVED BY: ESIMONSEN
PROJECT NAME: WALL DETAILS				
SCALE: NTS	SHEET NO: 11 OF 16	SIZE: A	TOLERANCES: ANGULAR $\pm 1^\circ$ LINEAR ± 0.06	



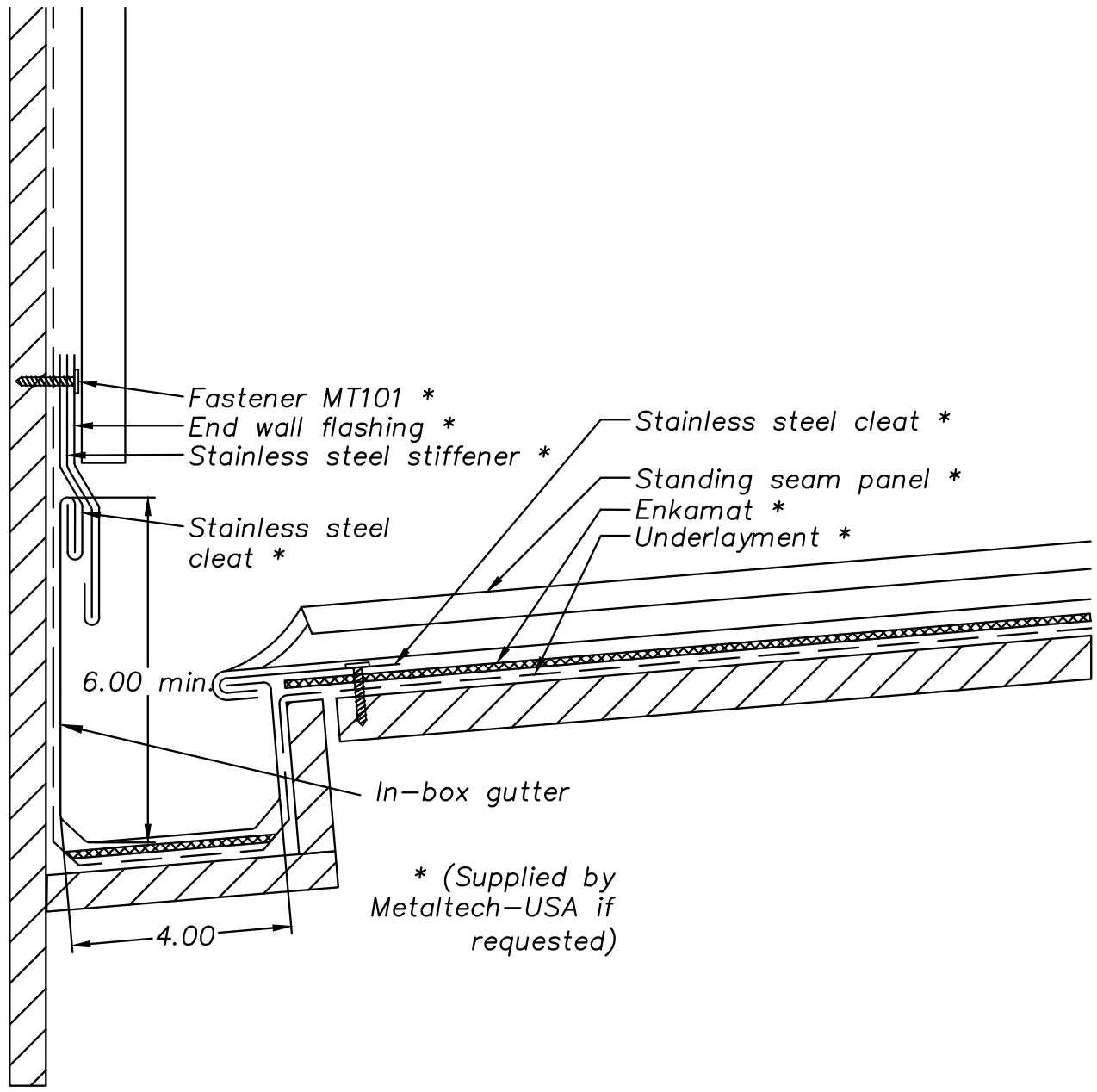

NOTE:
 Information and details are only a baseline for system and installation. Modification to meet project requirement is the responsibility of the designer, architect and contractor. MetalTech-USA project staff are available to assist throughout the design and build process. © 2011 MetalTech-USA. All rights reserved.

UNLESS OTHERWISE SPECIFIED DIMENSIONS ARE IN INCHES	DRAWING NAME: END WALL GUTTER OPTION		REVISION NO: A	DATED CREATED: 5/28/2015
	DWG NO: MT_SSRP_1512		CHECKED BY: ESIMONSEN	APPROVED BY: ESIMONSEN
				
PROJECT NAME: WALL DETAILS				
SCALE: NTS	SHEET NO: 12 OF 16	SIZE: A	TOLERANCES: ANGULAR ±1° LINEAR ±0.06	

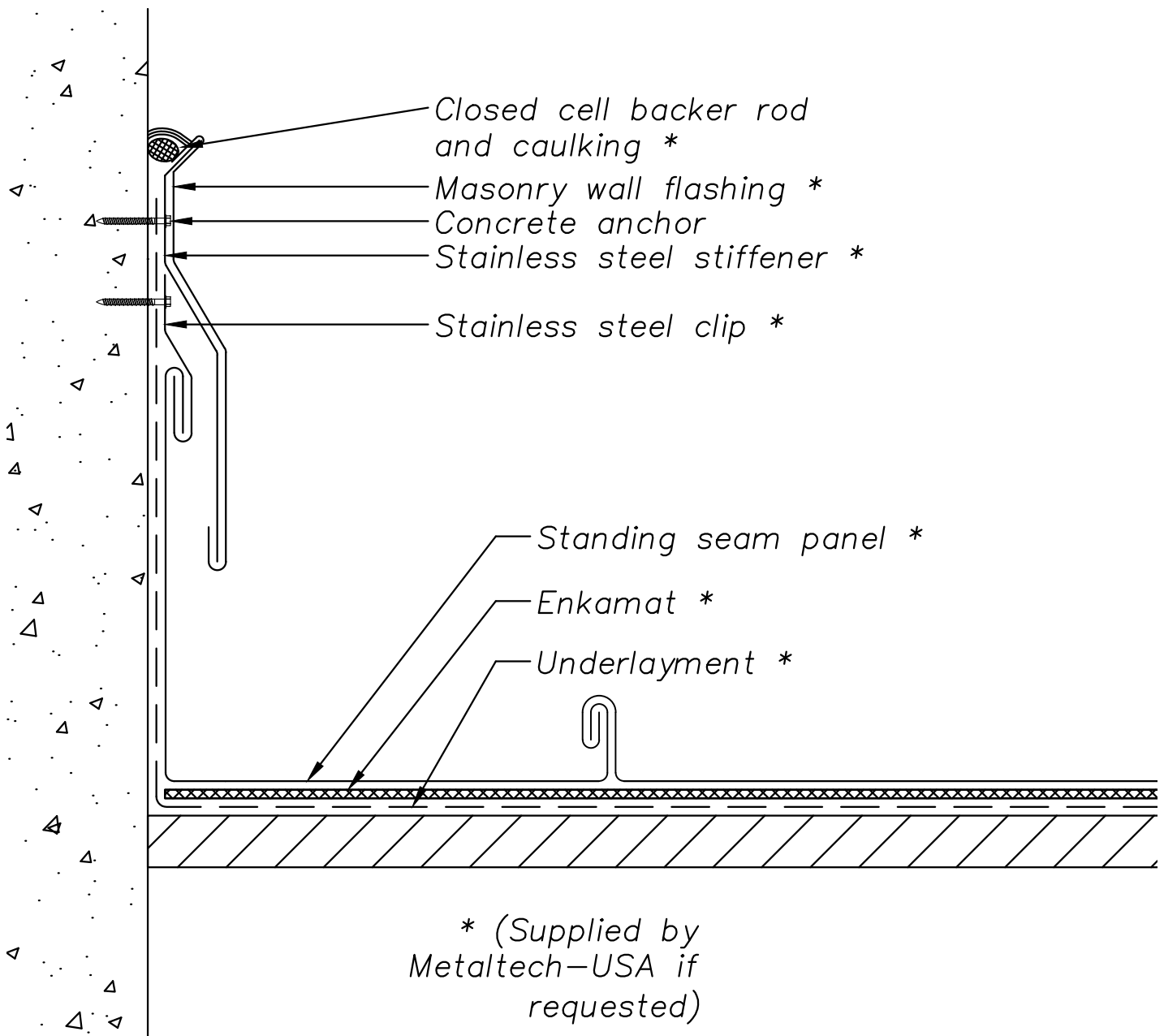

NOTE: Information and details are only a baseline for system and installation. Modification to meet project requirement is the responsibility of the designer, architect and contractor. MetalTech-USA project staff are available to assist throughout the design and build process. © 2011 MetalTech-USA. All rights reserved.

UNLESS OTHERWISE SPECIFIED DIMENSIONS ARE IN INCHES	DRAWING NAME: MASONRY SIDE WALL - OPTION 1		REVISION NO: A	DATED CREATED: 5/28/2015
	DWG NO: MT_SSRP_1513		CHECKED BY: ESIMONSEN	APPROVED BY: ESIMONSEN
				
PROJECT NAME: WALL DETAILS				
SCALE: NTS	SHEET NO: 13 OF 16	SIZE: A	TOLERANCES: ANGULAR $\pm 1^\circ$ LINEAR ± 0.06	

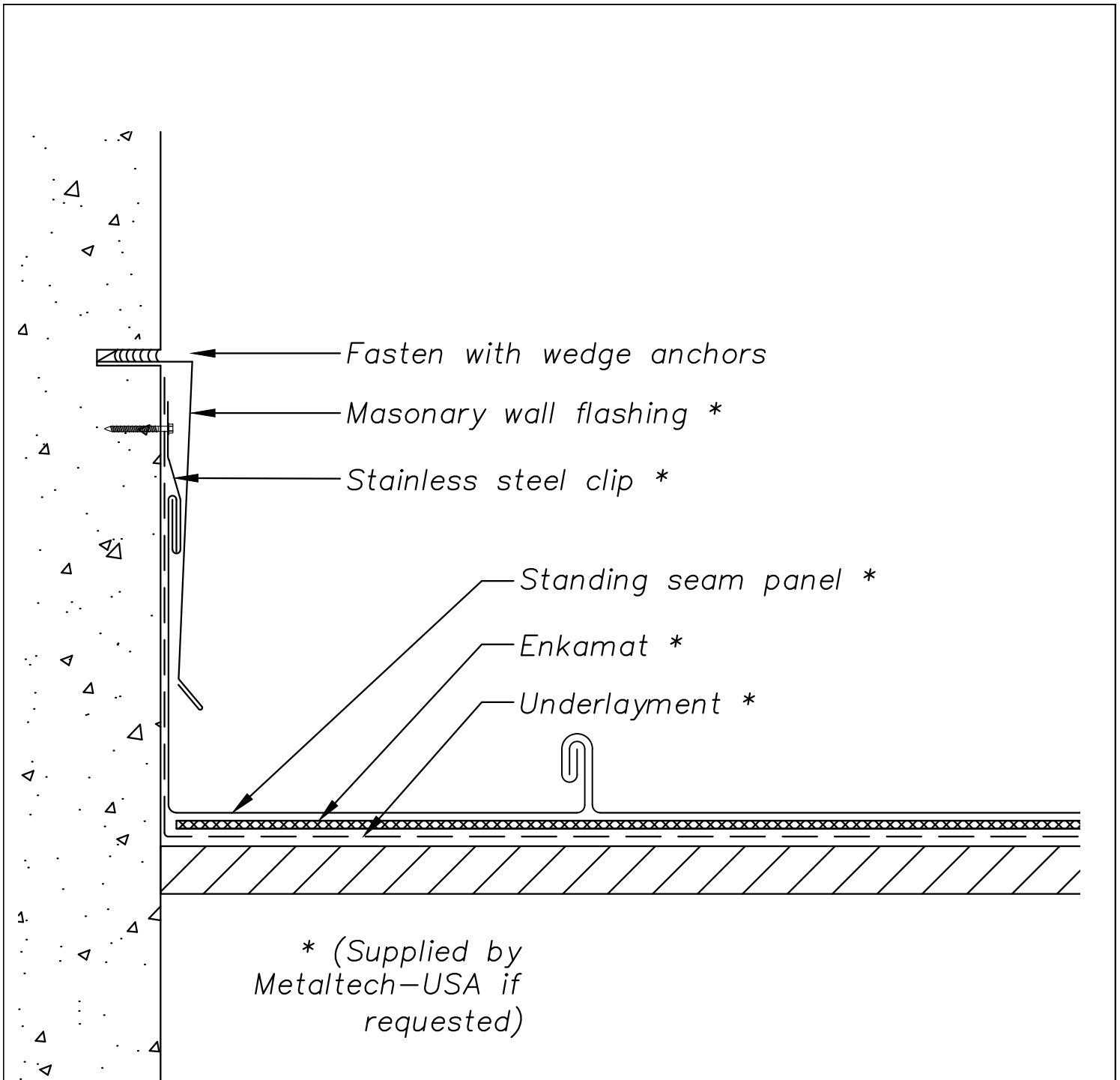

NOTE:
 Information and details are only a baseline for system and installation. Modification to meet project requirement is the responsibility of the designer, architect and contractor. MetalTech-USA project staff are available to assist throughout the design and build process. © 2011 MetalTech-USA. All rights reserved.

UNLESS OTHERWISE SPECIFIED DIMENSIONS ARE IN INCHES	DRAWING NAME: MASONRY SIDE WALL - OPTION 2		REVISION NO: A	DATED CREATED: 5/28/2015
	DWG NO: MT_SSRP_1514		CHECKED BY: ESIMONSEN	APPROVED BY: ESIMONSEN
PROJECT NAME: WALL DETAILS				
SCALE: NTS		SHEET NO: 14 OF 16	SIZE: A	TOLERANCES: ANGULAR $\pm 1^\circ$ LINEAR ± 0.06



* (Supplied by
Metaltech-USA if
requested)

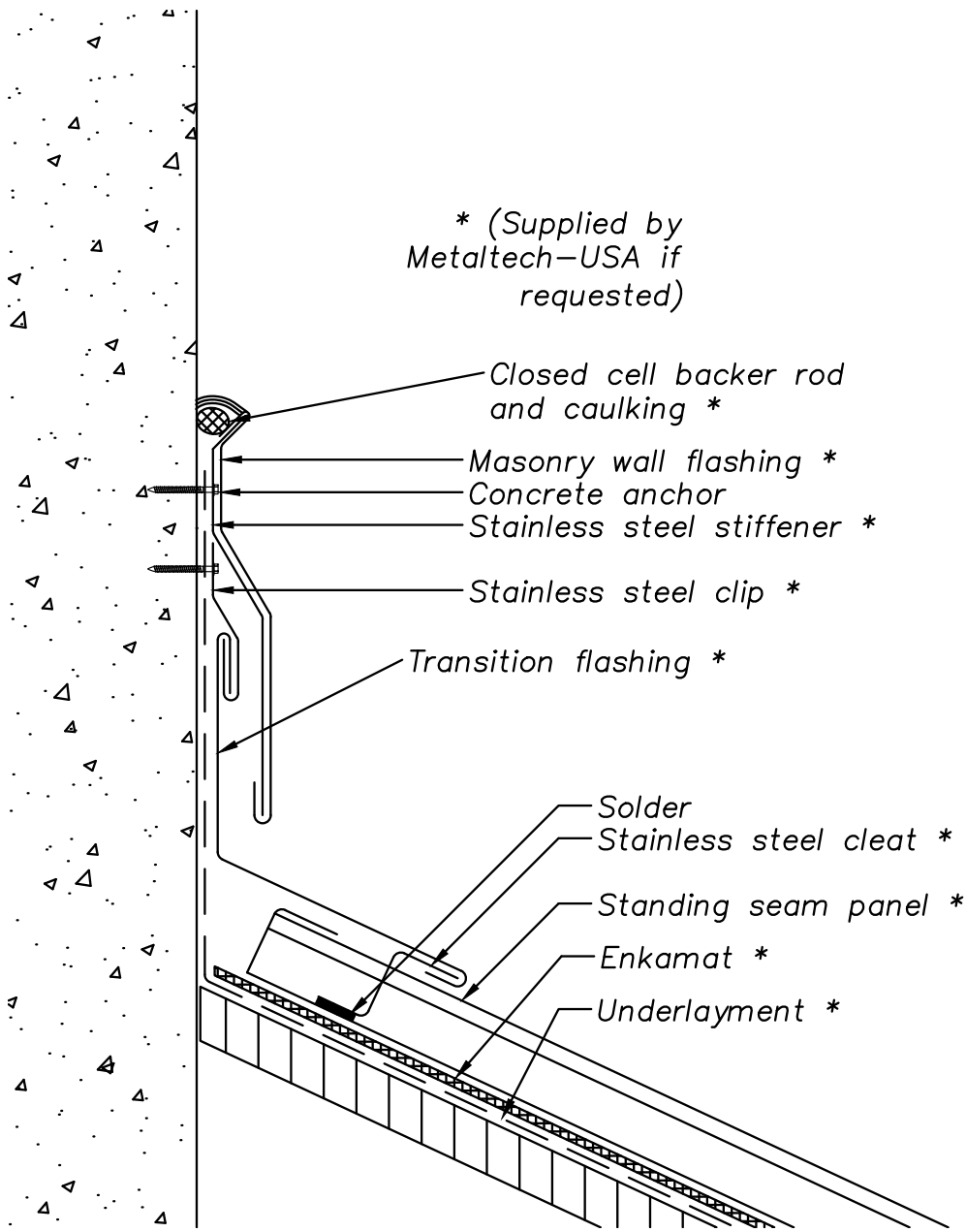

NOTE:
Information and details are only a baseline for system and installation. Modification to meet project requirement is the responsibility of the designer, architect and contractor. MetalTech-USA project staff are available to assist throughout the design and build process. © 2011 MetalTech-USA. All rights reserved.

UNLESS OTHERWISE SPECIFIED DIMENSIONS ARE IN INCHES	DRAWING NAME: MASONRY HEAD WALL - OPTION 1		REVISION NO: A	DATED CREATED: 5/28/2015
	DWG NO: MT_SSRP_1515		CHECKED BY: ESIMONSEN	APPROVED BY: ESIMONSEN
PROJECT NAME: WALL DETAILS				
SCALE: NTS		SHEET NO: 15 OF 16	SIZE: A	TOLERANCES: ANGULAR ±1° LINEAR ±0.06



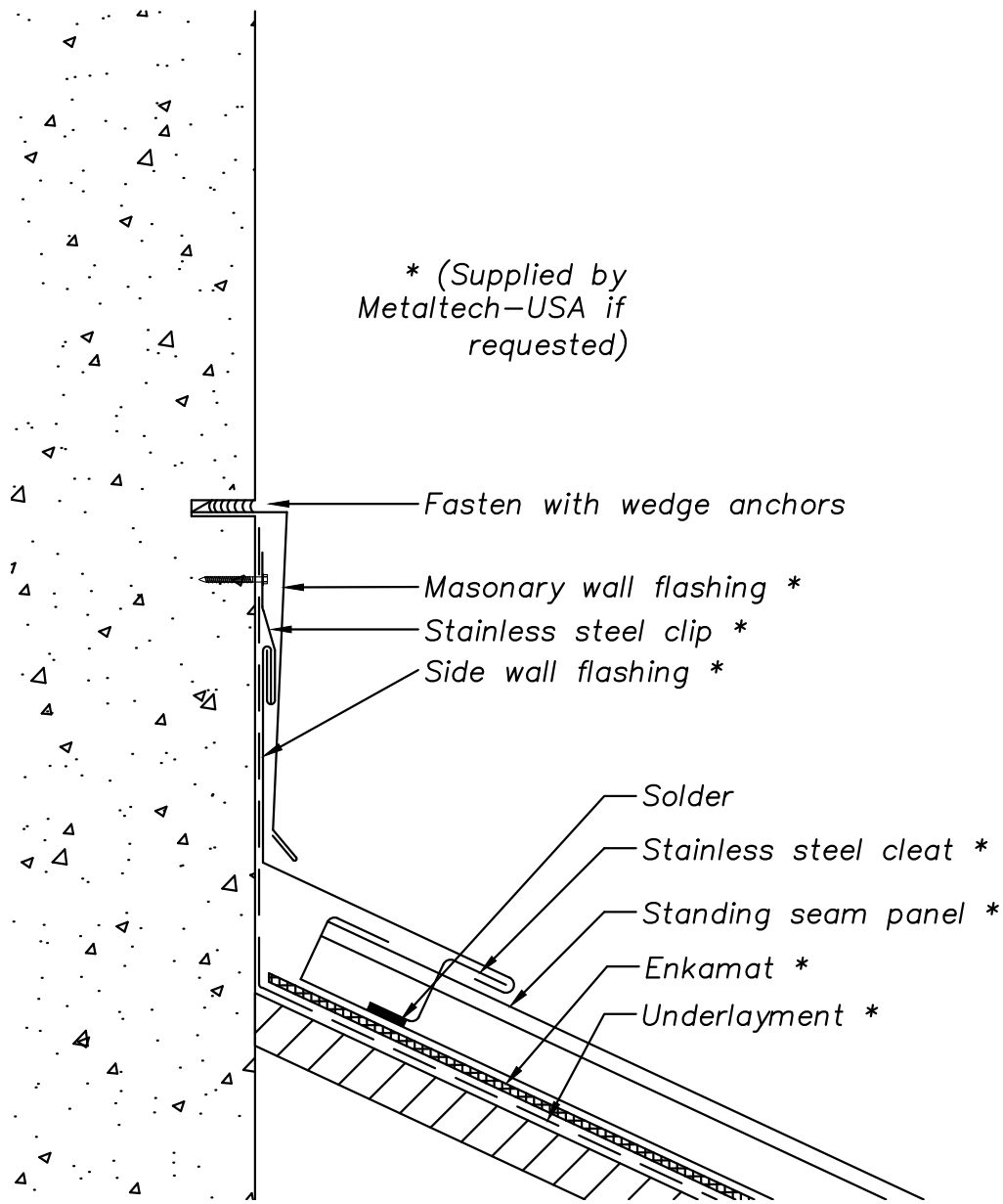



NOTE:
 Information and details are only a baseline for system and installation. Modification to meet project requirement is the responsibility of the designer, architect and contractor. MetalTech-USA project staff are available to assist throughout the design and build process. © 2011 MetalTech-USA. All rights reserved.

UNLESS OTHERWISE SPECIFIED DIMENSIONS ARE IN INCHES	DRAWING NAME: MASONRY HEAD WALL - OPTION 2		REVISION NO: A	DATED CREATED: 5/28/2015
	DWG NO: MT_SSRP_1516		CHECKED BY: ESIMONSEN	APPROVED BY: ESIMONSEN
PROJECT NAME: WALL DETAILS				
SCALE: NTS		SHEET NO: 16 OF 16	SIZE: A	TOLERANCES: ANGULAR ±1° LINEAR ±0.06

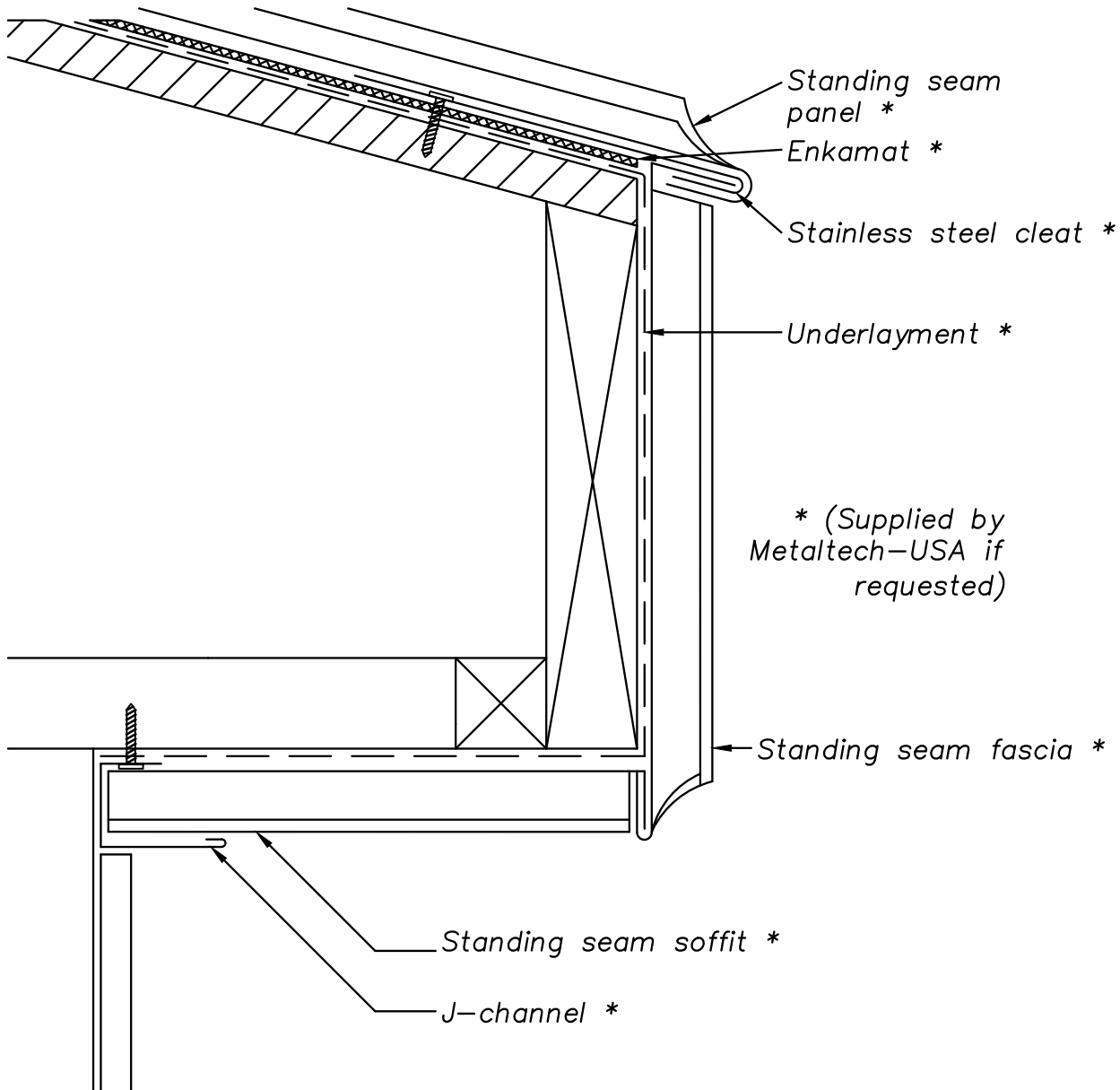



NOTE:
 Information and details are only a baseline for system and installation. Modification to meet project requirement is the responsibility of the designer, architect and contractor. MetalTech-USA project staff are available to assist throughout the design and build process. © 2011 MetalTech-USA. All rights reserved.

UNLESS OTHERWISE SPECIFIED DIMENSIONS ARE IN INCHES	DRAWING NAME: SOFFIT DETAIL - OPTION 1		REVISION NO: A	DATED CREATED: 5/1/2015
	DWG NO: MT_SSRP_1601		CHECKED BY: ESIMONSEN	APPROVED BY: ESIMONSEN
	PROJECT NAME: WALL DETAILS			
	SCALE: NTS	SHEET NO: 1 OF 4	SIZE: A	TOLERANCES: ANGULAR $\pm 1^\circ$ LINEAR ± 0.06

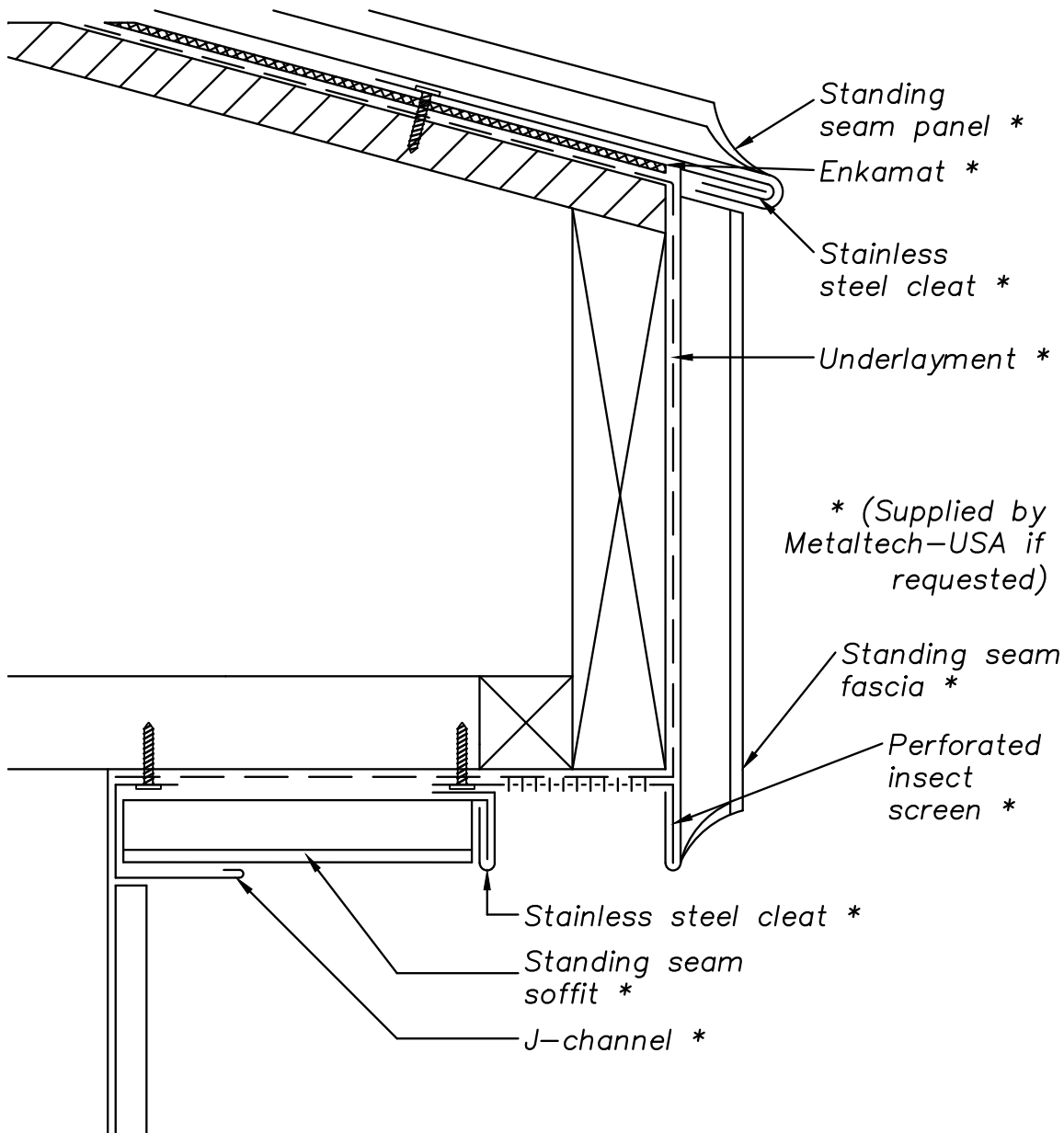

NOTE:
 Information and details are only a baseline for system and installation. Modification to meet project requirement is the responsibility of the designer, architect and contractor. MetalTech-USA project staff are available to assist throughout the design and build process. © 2011 MetalTech-USA. All rights reserved.

UNLESS OTHERWISE SPECIFIED DIMENSIONS ARE IN INCHES	DRAWING NAME: SOFFIT DETAIL - OPTION 2		REVISION NO: A	DATED CREATED: 5/1/2015
	DWG NO: MT_SSRP_1602		CHECKED BY: ESIMONSEN	APPROVED BY: ESIMONSEN
PROJECT NAME: WALL DETAILS				
SCALE: NTS	SHEET NO: 2 OF 4	SIZE: A	TOLERANCES: ANGULAR $\pm 1^\circ$ LINEAR ± 0.06	



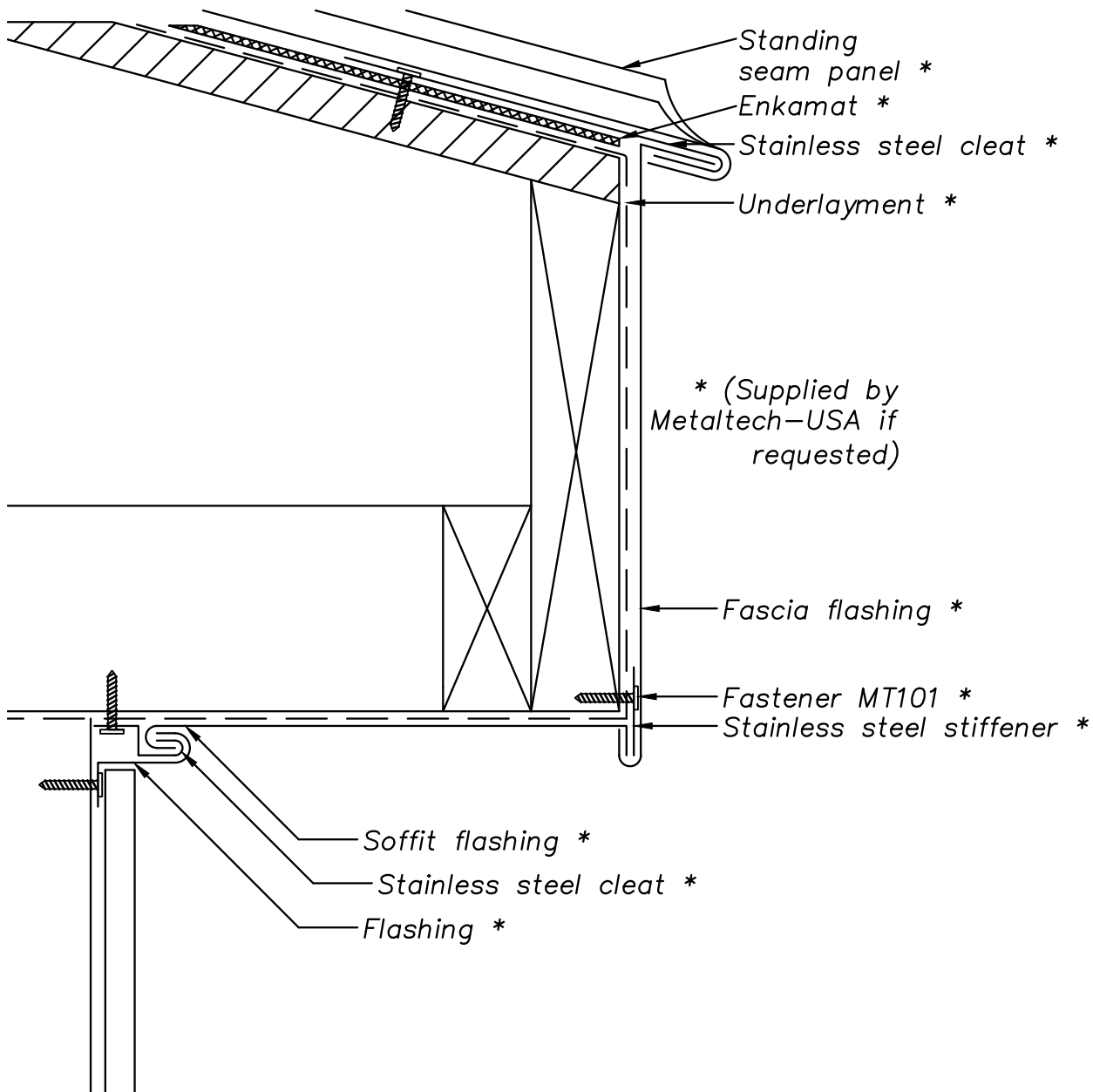

NOTE:
 Information and details are only a baseline for system and installation. Modification to meet project requirement is the responsibility of the designer, architect and contractor. MetalTech-USA project staff are available to assist throughout the design and build process. © 2011 MetalTech-USA. All rights reserved.

UNLESS OTHERWISE SPECIFIED DIMENSIONS ARE IN INCHES	DRAWING NAME: SOFFIT DETAIL - OPTION 3		REVISION NO: A	DATED CREATED: 5/1/2015
	DWG NO: MT_SSRP_1603		CHECKED BY: ESIMONSEN	APPROVED BY: ESIMONSEN
PROJECT NAME: WALL DETAILS				
SCALE: NTS		SHEET NO: 3 OF 4	SIZE: A	TOLERANCES: ANGULAR $\pm 1^\circ$ LINEAR ± 0.06



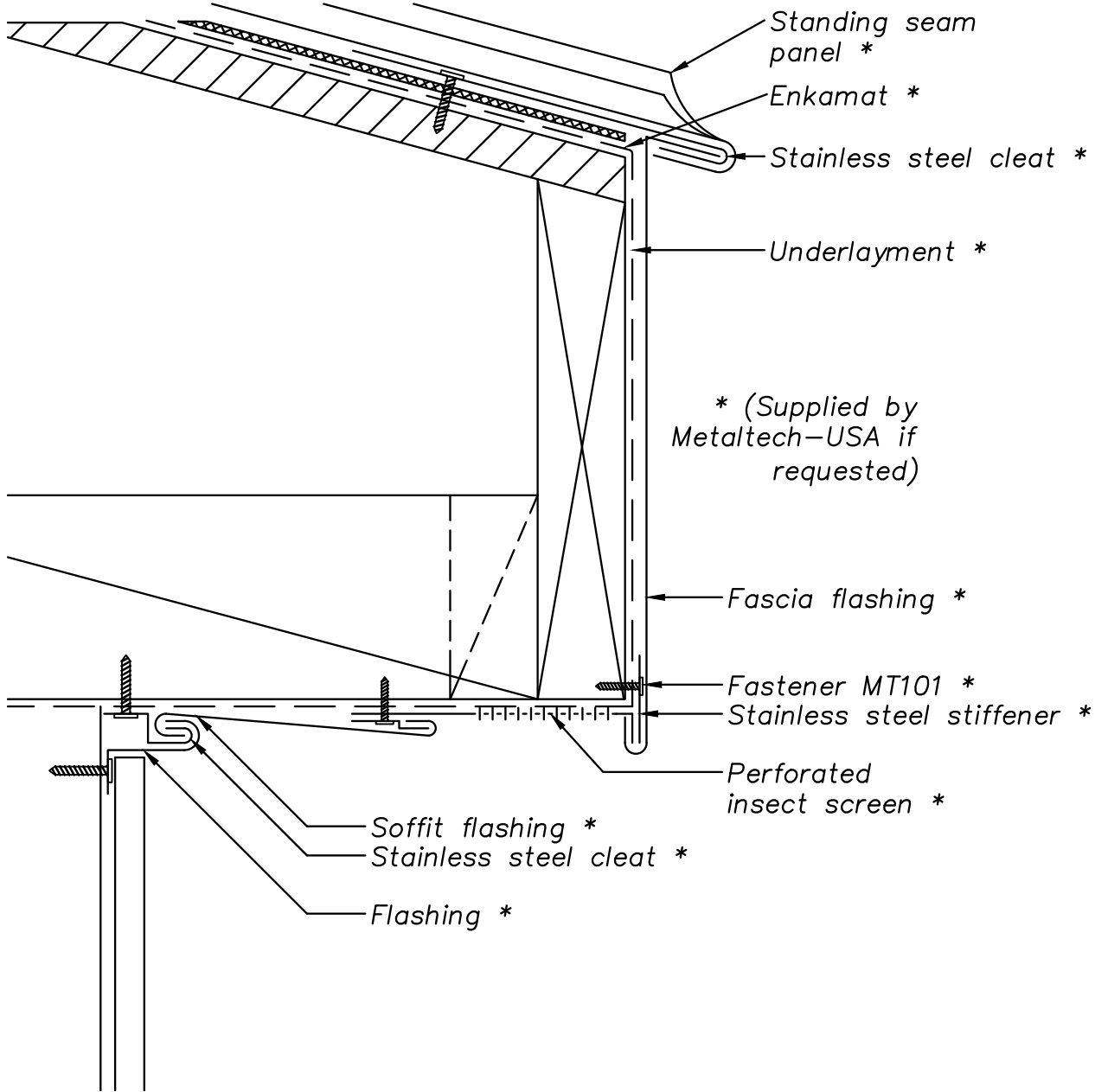

NOTE:
 Information and details are only a baseline for system and installation. Modification to meet project requirement is the responsibility of the designer, architect and contractor. MetalTech-USA project staff are available to assist throughout the design and build process. © 2011 MetalTech-USA. All rights reserved.

UNLESS OTHERWISE SPECIFIED DIMENSIONS ARE IN INCHES	DRAWING NAME: SOFFIT DETAIL - OPTION 4		REVISION NO: A	DATED CREATED: 5/1/2015
	DWG NO: MT_SSRP_1604		CHECKED BY: ESIMONSEN	APPROVED BY: ESIMONSEN
PROJECT NAME: WALL DETAILS				
SCALE: NTS		SHEET NO: 4 OF 4	SIZE: A	TOLERANCES: ANGULAR $\pm 1^\circ$ LINEAR ± 0.06



* (Supplied by Metaltech-USA if requested)

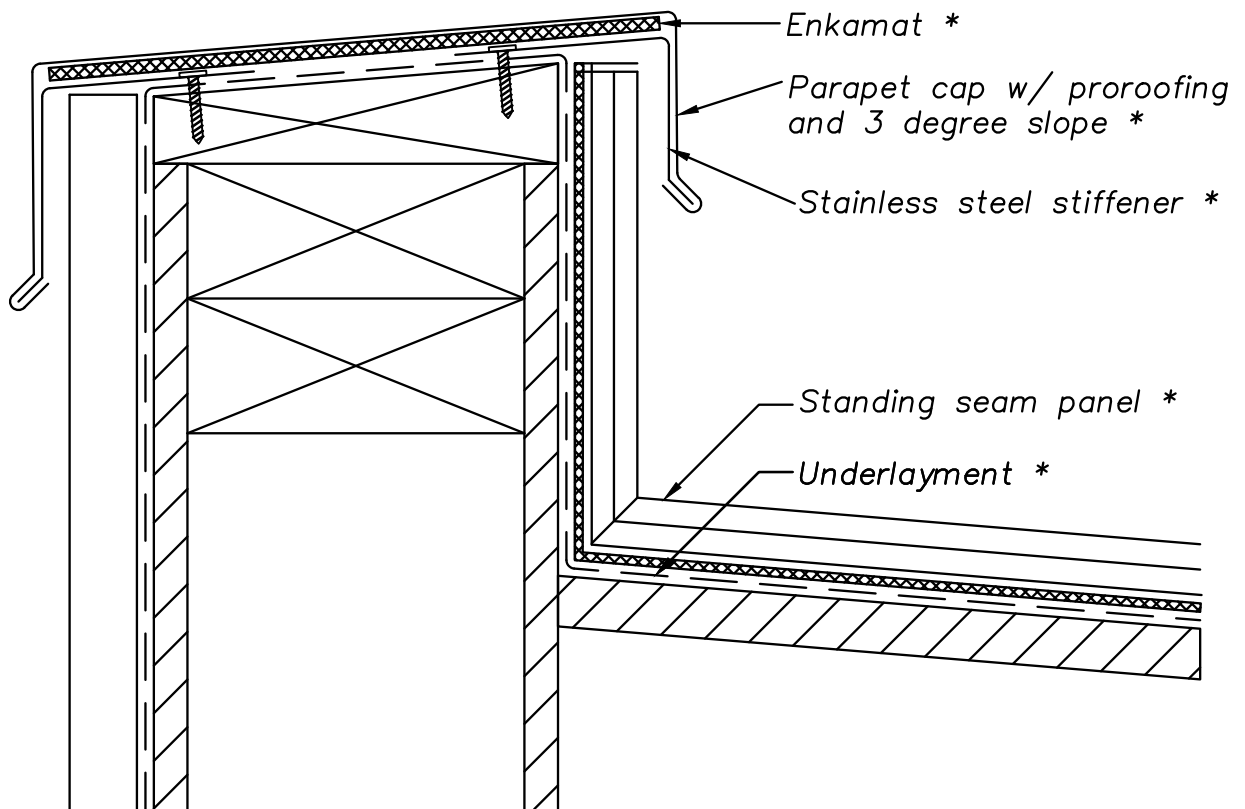

NOTE:
 Information and details are only a baseline for system and installation. Modification to meet project requirement is the responsibility of the designer, architect and contractor. MetalTech-USA project staff are available to assist throughout the design and build process. © 2011 MetalTech-USA. All rights reserved.

UNLESS OTHERWISE SPECIFIED DIMENSIONS ARE IN INCHES	DRAWING NAME: PARAPET DETAIL – OPTION 1	REVISION NO: A	DATED CREATED: 5/1/2015
	DWG NO: MT_SSRP_1701	CHECKED BY: ESIMONSEN	APPROVED BY: ESIMONSEN
	PROJECT NAME: PARAPET DETAILS		
	SCALE: NTS	SHEET NO: 1 OF 3	SIZE: A

* (Supplied by
Metaltech-USA if
requested)

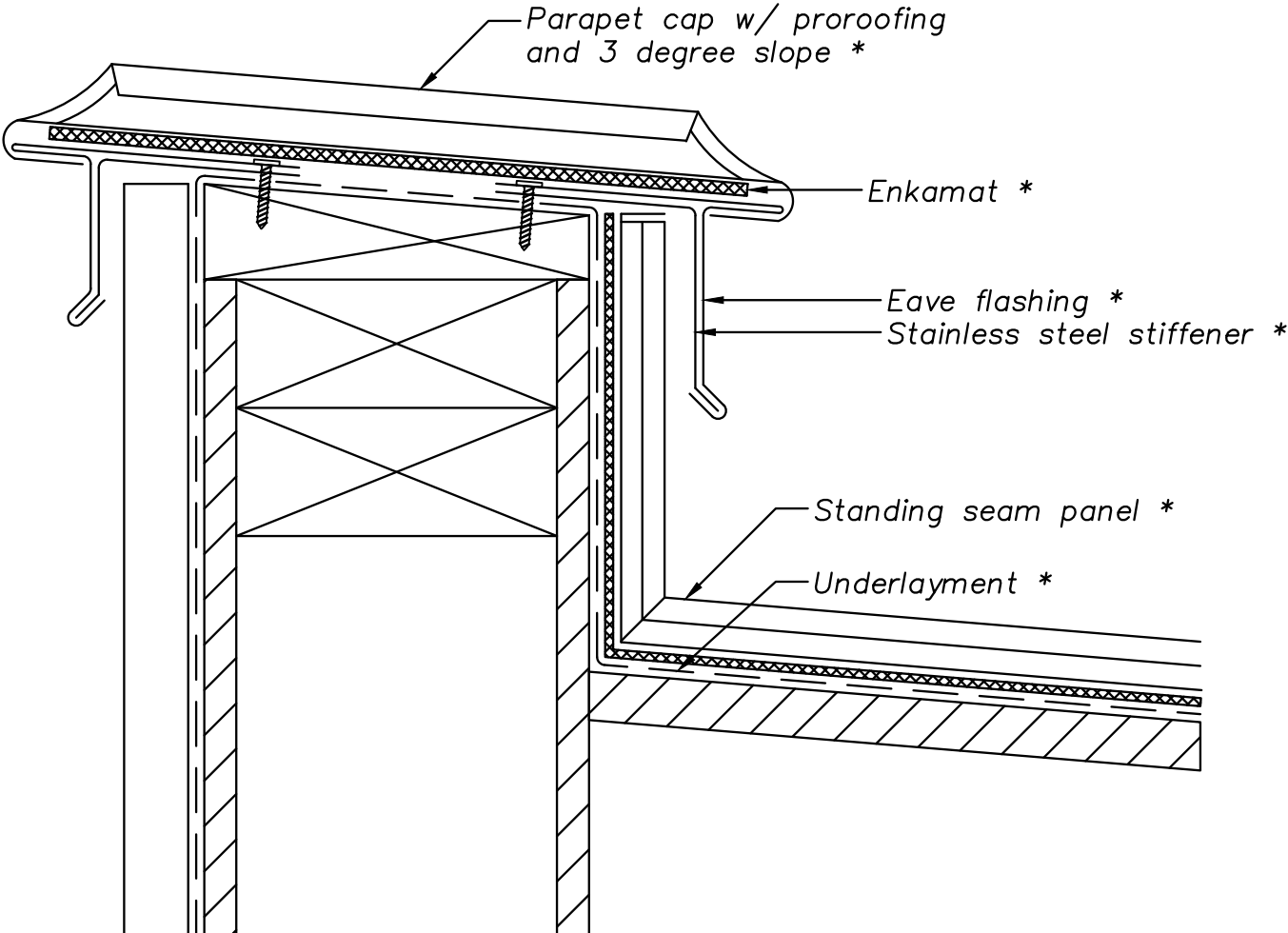

NOTE:
Information and details are only a baseline for system and installation. Modification to meet project requirement is the responsibility of the designer, architect and contractor. MetalTech-USA project staff are available to assist throughout the design and build process. © 2011 MetalTech-USA. All rights reserved.

<p>UNLESS OTHERWISE SPECIFIED DIMENSIONS ARE IN INCHES</p>	<p>DRAWING NAME: PARAPET DETAIL - OPTION 2</p>		<p>REVISION NO: A</p>	<p>DATED CREATED: 5/1/2015</p>	
	<p>DWG NO: MT_SSRP_1702</p>		<p>CHECKED BY: ESIMONSEN</p>	<p>APPROVED BY: ESIMONSEN</p>	
 <p>METALTECH Global <small>a Forza Group Company</small> DESIGNING STRENGTH</p>	<p>PROJECT NAME: PARAPET DETAILS</p>				
	<p>SCALE: NTS</p>	<p>SHEET NO: 2 OF 3</p>	<p>SIZE: A</p>	<p>TOLERANCES: ANGULAR ±1° LINEAR ±0.06</p>	

* (Supplied by Metaltech-USA if requested)

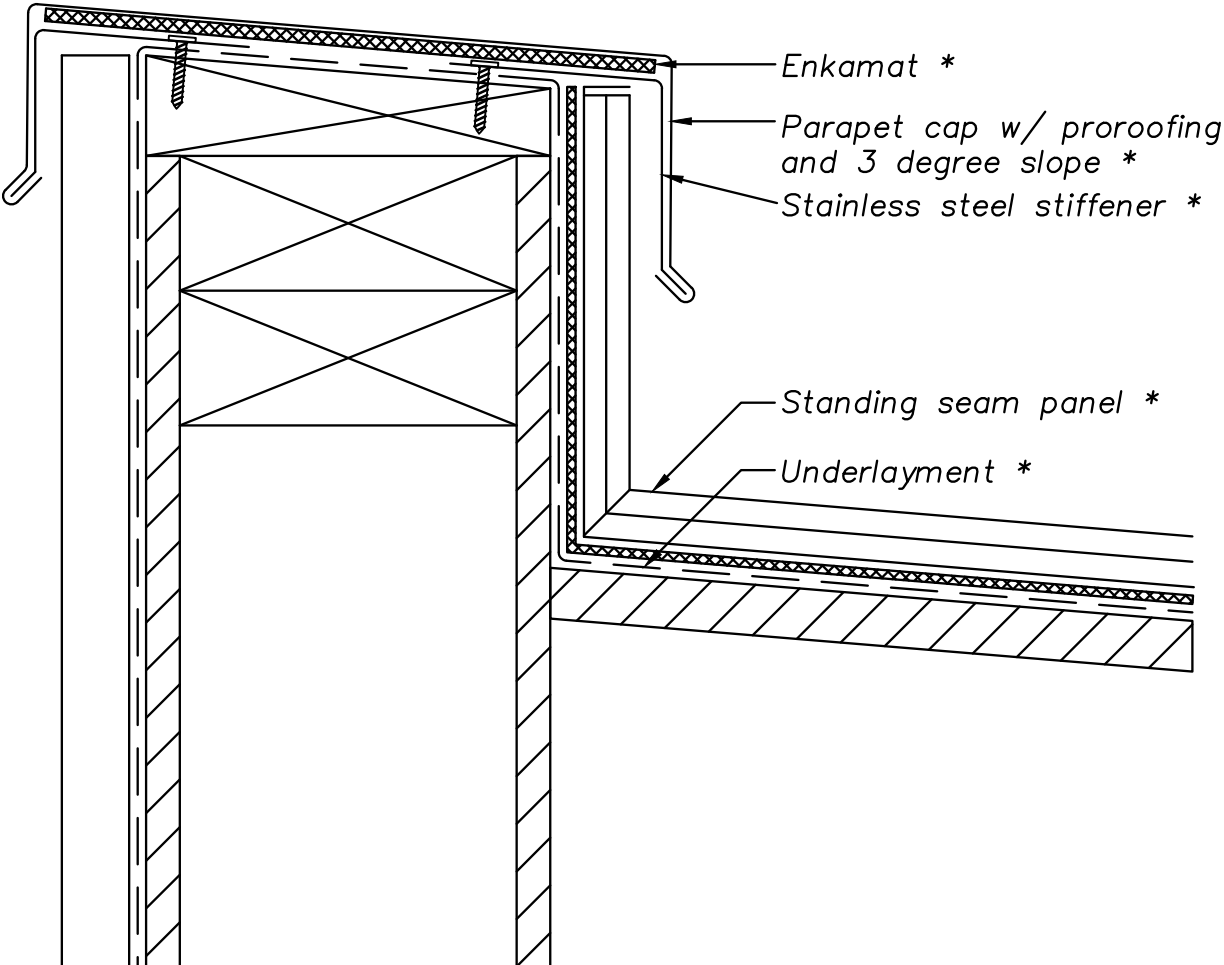

NOTE:
 Information and details are only a baseline for system and installation. Modification to meet project requirement is the responsibility of the designer, architect and contractor. MetalTech-USA project staff are available to assist throughout the design and build process. © 2011 MetalTech-USA. All rights reserved.

UNLESS OTHERWISE SPECIFIED DIMENSIONS ARE IN INCHES	DRAWING NAME: PARAPET DETAIL – OPTION 3		REVISION NO: A	DATED CREATED: 5/1/2015
	DWG NO: MT_SSRP_1703		CHECKED BY: ESIMONSEN	APPROVED BY: ESIMONSEN
				
PROJECT NAME: PARAPET DETAILS		SCALE: NTS	SHEET NO: 3 OF 3	SIZE: A
TOLERANCES: ANGULAR ±1° LINEAR ±0.06				

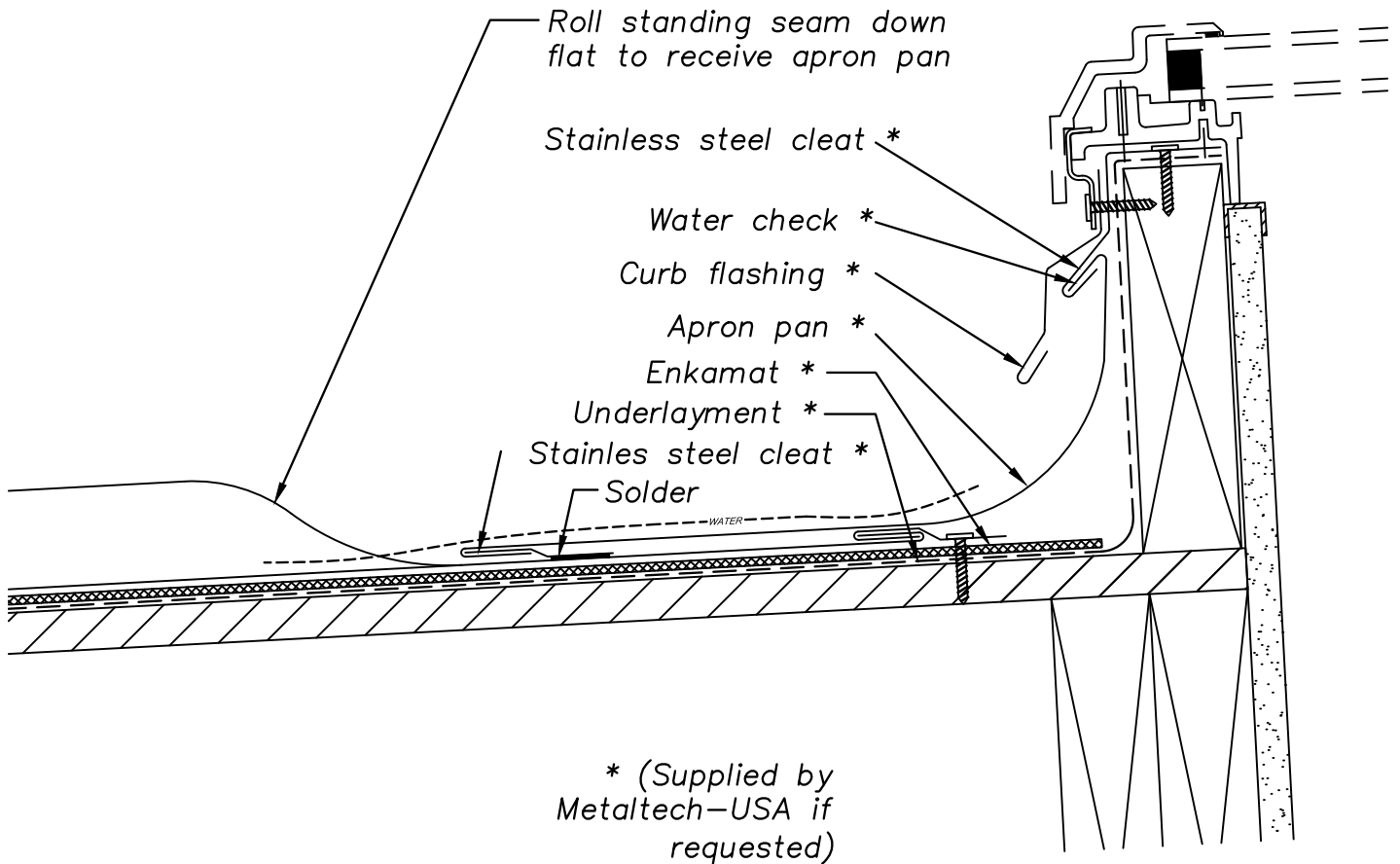

NOTE:
 Information and details are only a baseline for system and installation. Modification to meet project requirement is the responsibility of the designer, architect and contractor. MetalTech-USA project staff are available to assist throughout the design and build process. © 2011 MetalTech-USA. All rights reserved.

UNLESS OTHERWISE SPECIFIED DIMENSIONS ARE IN INCHES	DRAWING NAME: BOTTOM OF SKYLIGHT		REVISION NO: A	DATED CREATED: 6/10/2015	
	DWG NO: MT_SSRP_1801		CHECKED BY: ESIMONSEN	APPROVED BY: ESIMONSEN	
 a Forza Group Company DESIGNING STRENGTH	PROJECT NAME: SKYLIGHT DETAILS				
	SCALE: NTS	SHEET NO: 1 OF 6	SIZE: A	TOLERANCES: ANGULAR $\pm 1^\circ$ LINEAR ± 0.06	

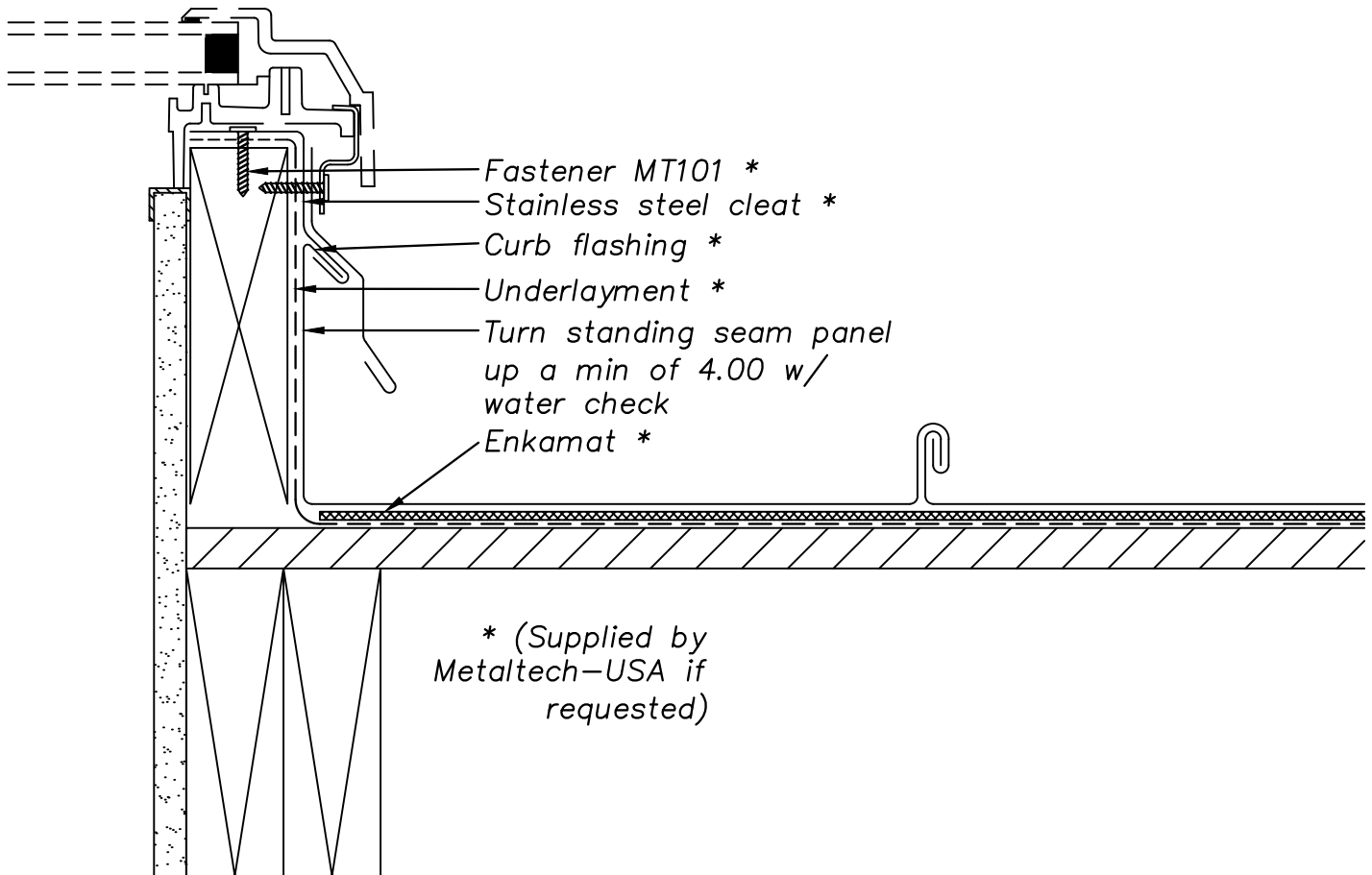

NOTE:
 Information and details are only a baseline for system and installation. Modification to meet project requirement is the responsibility of the designer, architect and contractor. MetalTech-USA project staff are available to assist throughout the design and build process. © 2011 MetalTech-USA. All rights reserved.

	DRAWING NAME: SIDE OF SKYLIGHT		REVISION NO: A	DATED CREATED: 6/10/2015
	DWG NO: MT_SSRP_1802		CHECKED BY: ESIMONSEN	APPROVED BY: ESIMONSEN
PROJECT NAME: SKYLIGHT DETAILS				
SCALE: NTS	SHEET NO: 2 OF 6	SIZE: A	TOLERANCES: ANGULAR $\pm 1^\circ$ LINEAR ± 0.06	

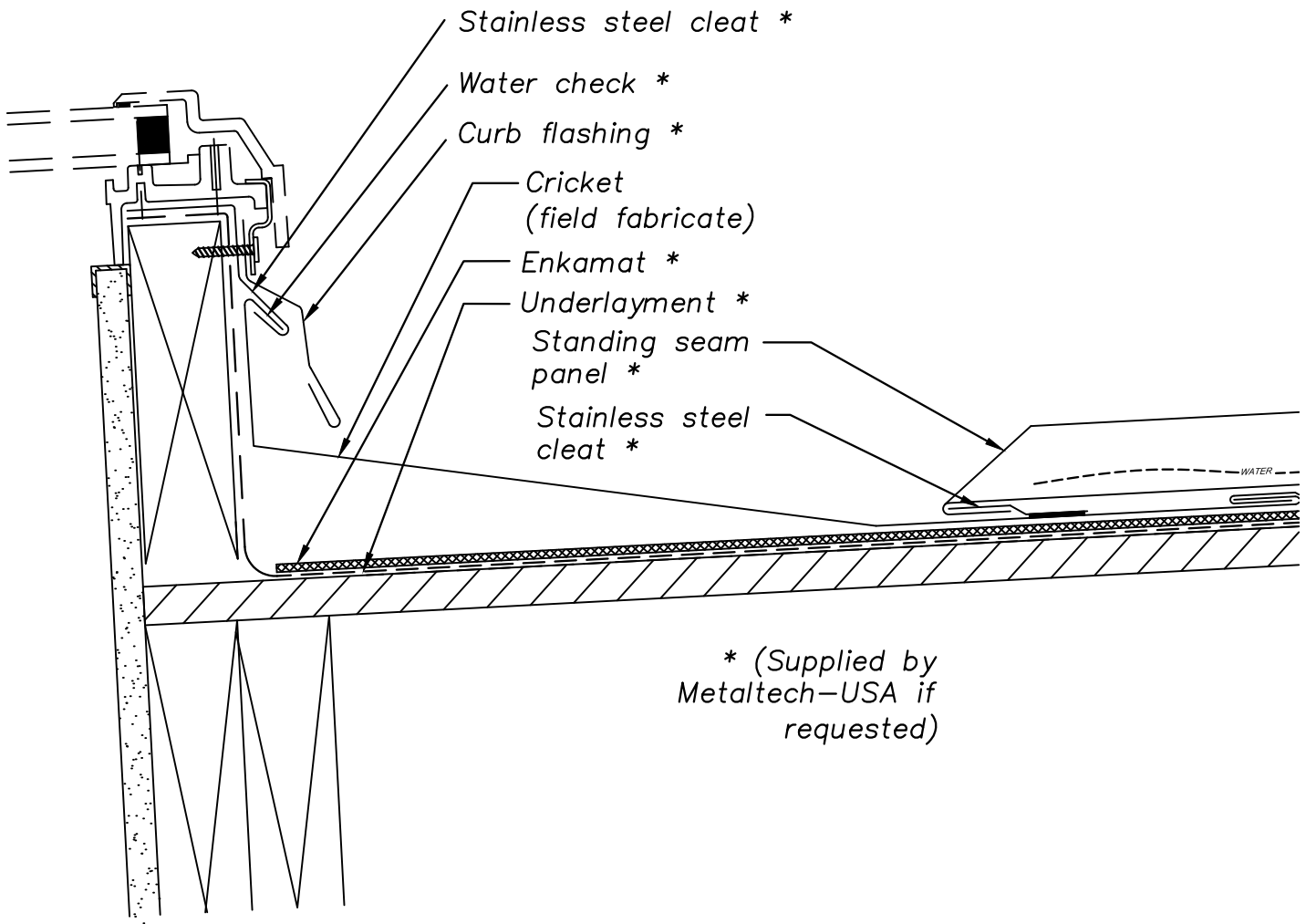

NOTE:
Information and details are only a baseline for system and installation. Modification to meet project requirement is the responsibility of the designer, architect and contractor. MetalTech-USA project staff are available to assist throughout the design and build process. © 2011 MetalTech-USA. All rights reserved.

 <p>METALTECH Global a Forza Group Company DESIGNING STRENGTH</p>	DRAWING NAME: TOP OF SKYLIGHT		REVISION NO: A	DATED CREATED: 6/10/2015
	DWG NO: MT_SSRP_1803		CHECKED BY: ESIMONSEN	APPROVED BY: ESIMONSEN
	PROJECT NAME: SKYLIGHT DETAILS			
	SCALE: NTS	SHEET NO: 3 OF 6	SIZE: A	TOLERANCES: ANGULAR ±1° LINEAR ±0.06

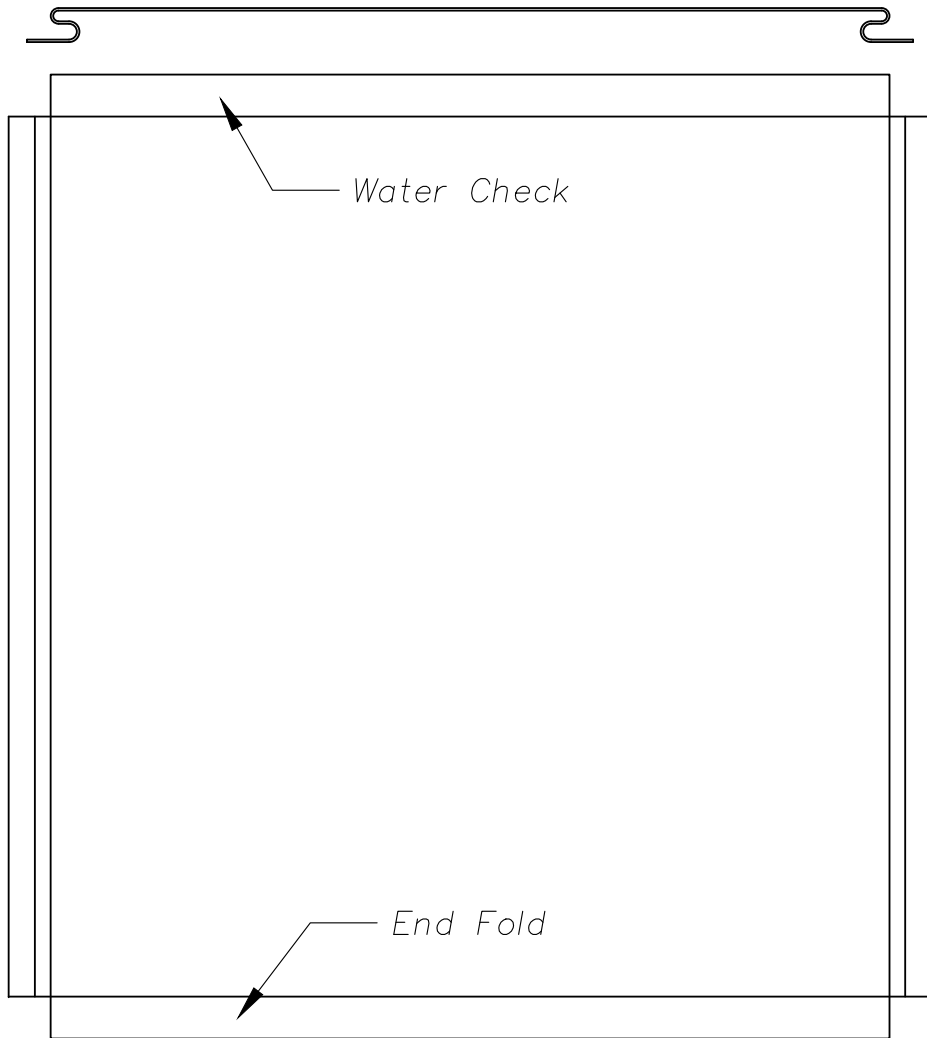

NOTE:
 Information and details are only a baseline for system and installation. Modification to meet project requirement is the responsibility of the designer, architect and contractor. MetalTech–USA project staff are available to assist throughout the design and build process. © 2011 MetalTech–USA. All rights reserved.

UNLESS OTHERWISE SPECIFIED DIMENSIONS ARE IN INCHES	DRAWING NAME: FLAT PATTERN OF APRON PAN		REVISION NO: A	DATED CREATED: 6/10/2015
	DWG NO: MT_SSRP_1804		CHECKED BY: ESIMONSEN	APPROVED BY: ESIMONSEN
	PROJECT NAME: SKYLIGHT DETAILS			
SCALE: NTS	SHEET NO: 4 OF 6	SIZE: A	TOLERANCES: ANGULAR ±1° LINEAR ±0.06	

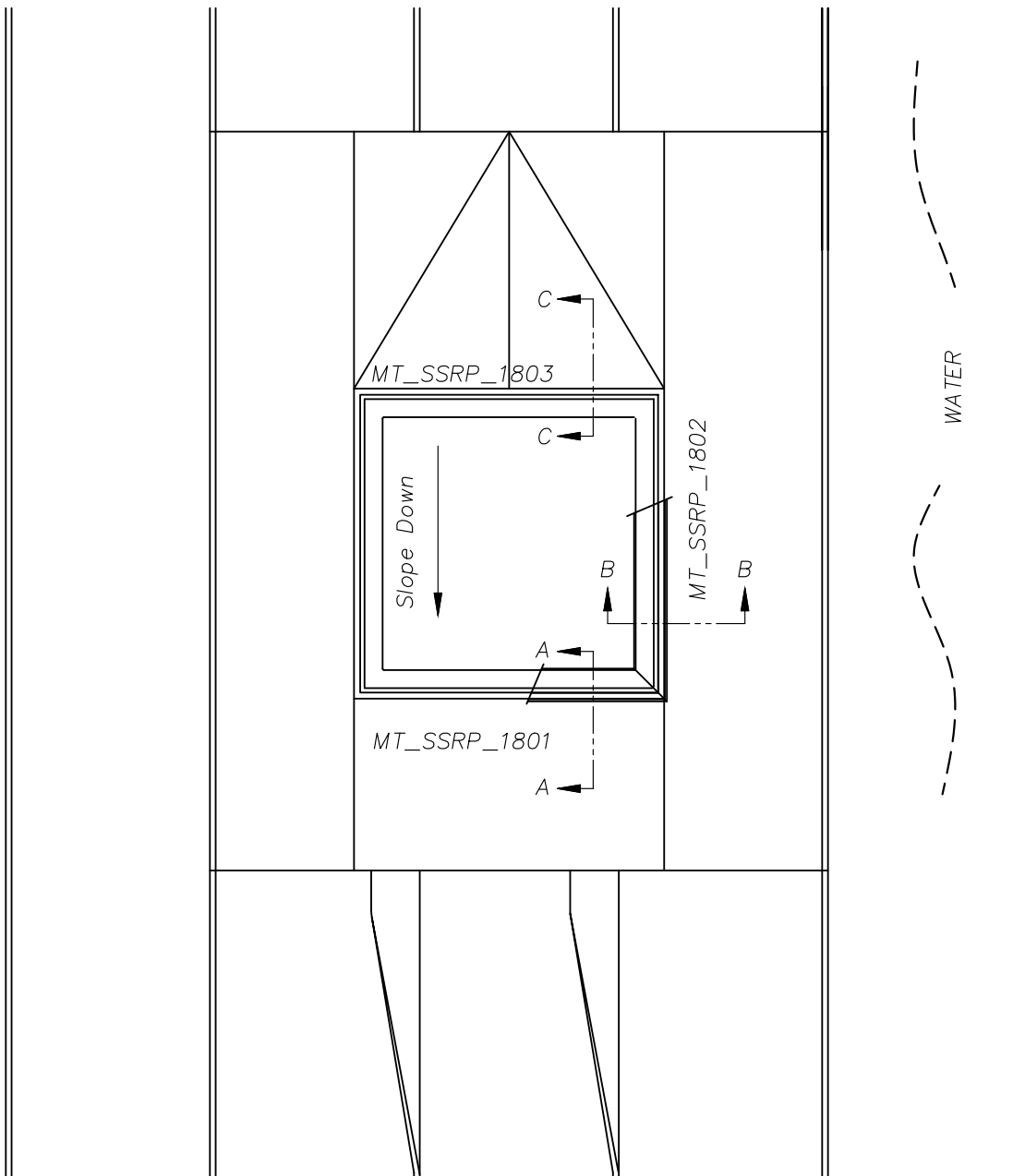

NOTE:
 Information and details are only a baseline for system and installation. Modification to meet project requirement is the responsibility of the designer, architect and contractor. MetalTech—USA project staff are available to assist throughout the design and build process. © 2011 MetalTech—USA. All rights reserved.

	UNLESS OTHERWISE SPECIFIED DIMENSIONS ARE IN INCHES		DRAWING NAME: SKYLIGHT PANEL LAYOUT— PLAN VIEW	REVISION NO: A	DATED CREATED: 6/10/2015
	DWG NO: MT_SSRP_1805		CHECKED BY: ESIMONSEN	APPROVED BY: ESIMONSEN	
	PROJECT NAME: SKYLIGHT DETAILS				
	SCALE: NTS	SHEET NO: 5 OF 6	SIZE: A	TOLERANCES: ANGULAR ±1° LINEAR ±0.06	

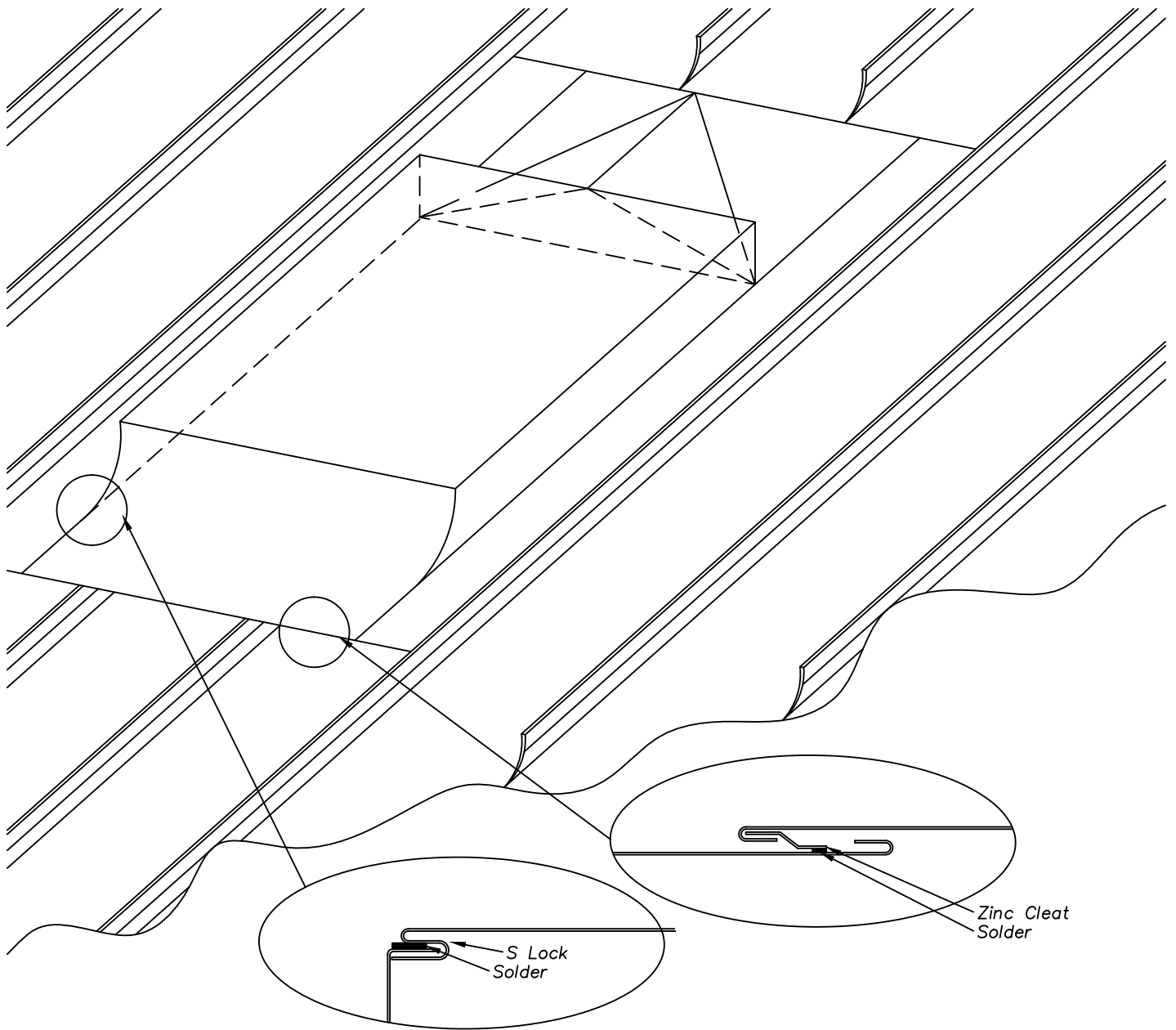

NOTE:
 Information and details are only a baseline for system and installation. Modification to meet project requirement is the responsibility of the designer, architect and contractor. MetalTech-USA project staff are available to assist throughout the design and build process. © 2011 MetalTech-USA. All rights reserved.

UNLESS OTHERWISE SPECIFIED DIMENSIONS ARE IN INCHES	DRAWING NAME: SKYLIGHT PANEL LAYOUT- ISOMETRIC VIEW	REVISION NO: A	DATED CREATED: 6/10/2015
	DWG NO: MT_SSRP_1806	CHECKED BY: ESIMONSEN	APPROVED BY: ESIMONSEN
	PROJECT NAME: SKYLIGHT DETAILS		
SCALE: NTS	SHEET NO: 6 OF 6	SIZE: A	TOLERANCES: ANGULAR ±1° LINEAR ±0.06

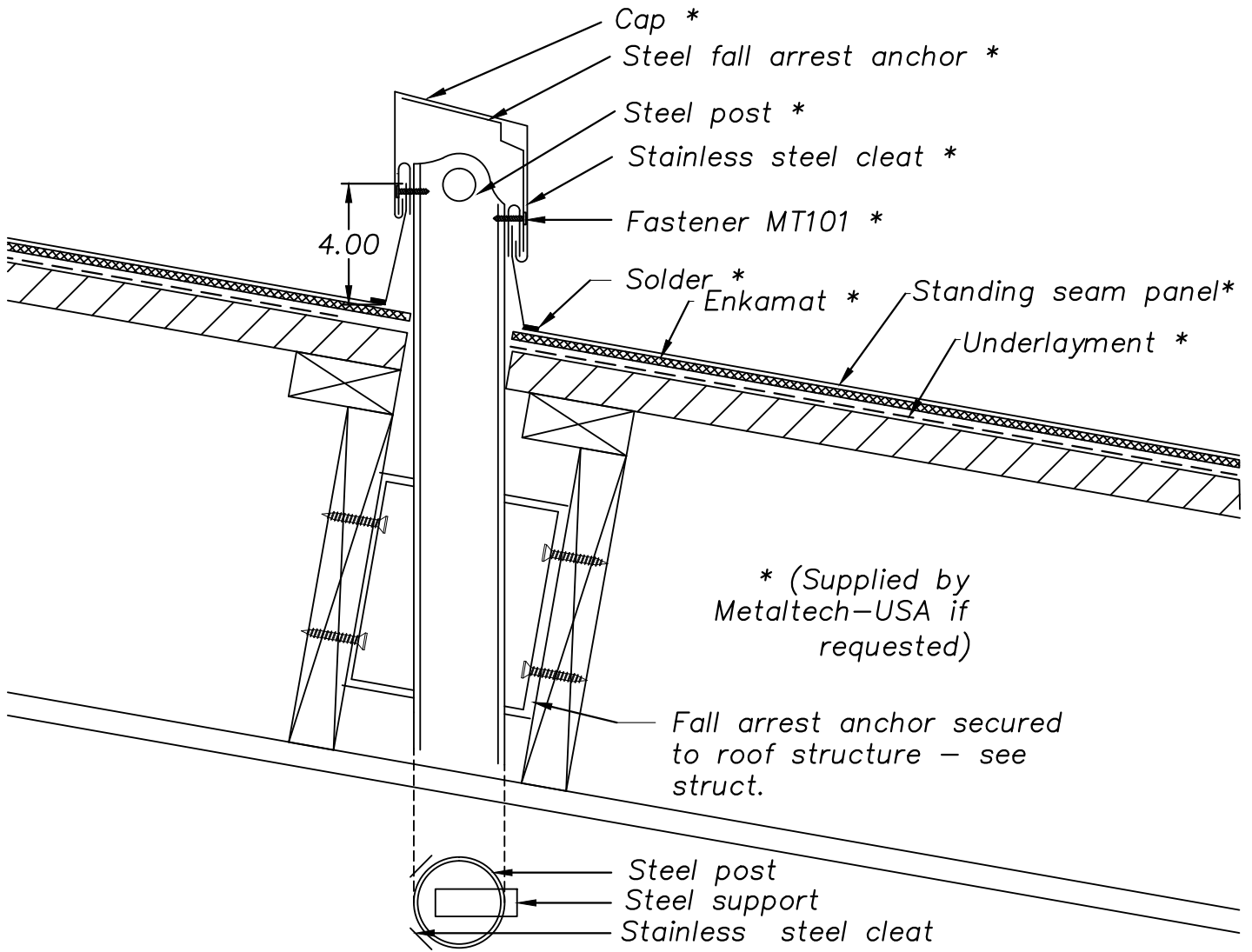

NOTE:

Information and details are only a baseline for system and installation. Modification to meet project requirement is the responsibility of the designer, architect and contractor. MetalTech-USA project staff are available to assist throughout the design and build process. © 2011 MetalTech-USA. All rights reserved.

<p>UNLESS OTHERWISE SPECIFIED DIMENSIONS ARE IN INCHES</p>	<p>DRAWING NAME: ROOF PENETRATION – OPTION 1</p>		<p>REVISION NO: A</p>	<p>DATED CREATED: 6/17/2015</p>
	<p>DWG NO: MT_SSRP_1901</p>		<p>CHECKED BY: ESIMONSEN</p>	<p>APPROVED BY: ESIMONSEN</p>
	<p>PROJECT NAME: MISCELLANEOUS DETAILS</p>			
	<p>SCALE: NTS</p>	<p>SHEET NO: 1 OF 6</p>	<p>SIZE: A</p>	<p>TOLERANCES: ANGULAR ±1° LINEAR ±0.06</p>

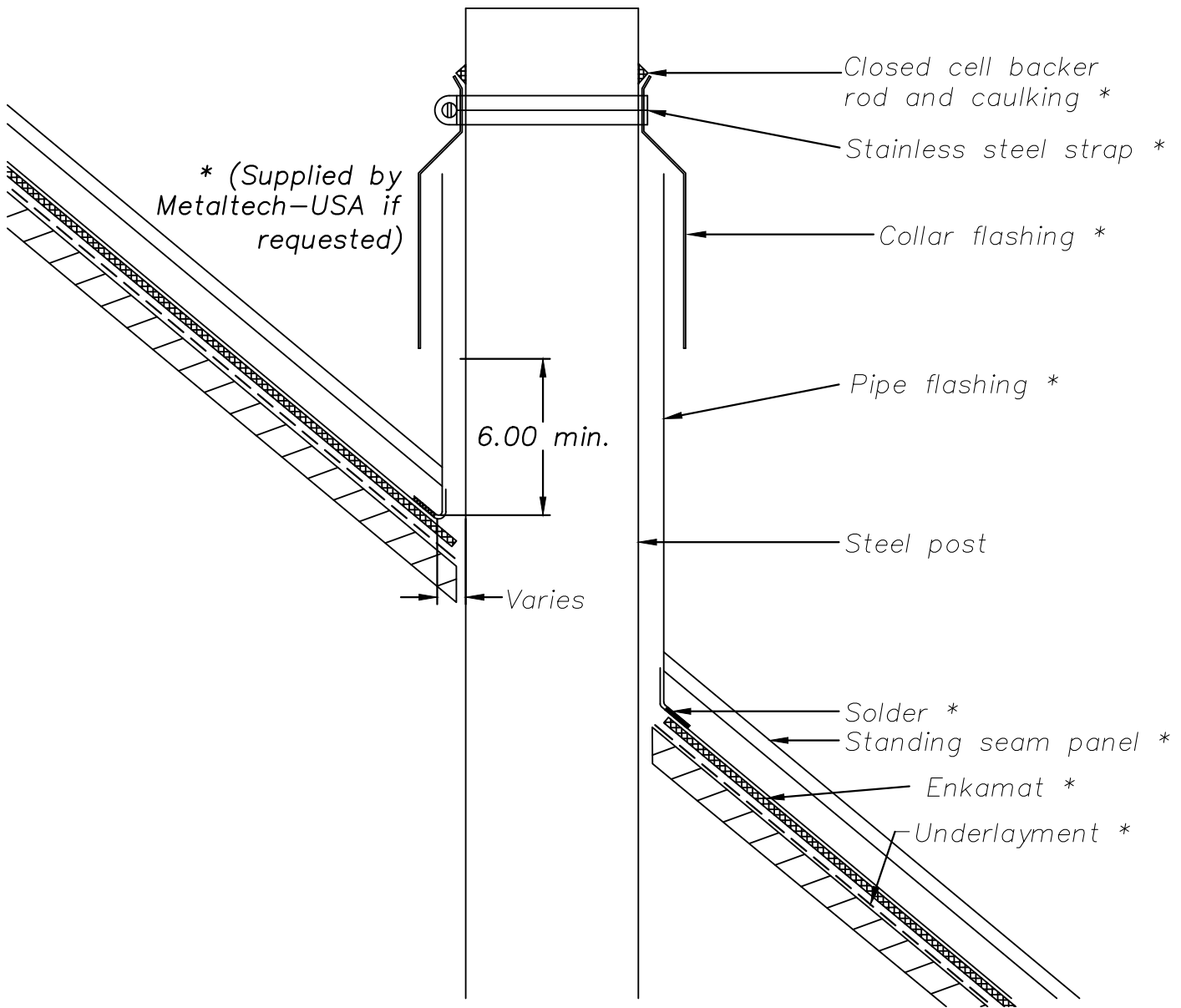

NOTE:
 Information and details are only a baseline for system and installation. Modification to meet project requirement is the responsibility of the designer, architect and contractor. MetalTech-USA project staff are available to assist throughout the design and build process. © 2011 MetalTech-USA. All rights reserved.

UNLESS OTHERWISE SPECIFIED DIMENSIONS ARE IN INCHES	DRAWING NAME: ROOF PENETRATION - OPTION 2		REVISION NO: A	DATED CREATED: 6/17/2015
	DWG NO: MT_SSRP_1902		CHECKED BY: ESIMONSEN	APPROVED BY: ESIMONSEN
PROJECT NAME: MISCELLANEOUS DETAILS				
SCALE: NTS		SHEET NO: 2 OF 6	SIZE: A	TOLERANCES: ANGULAR $\pm 1^\circ$ LINEAR ± 0.06



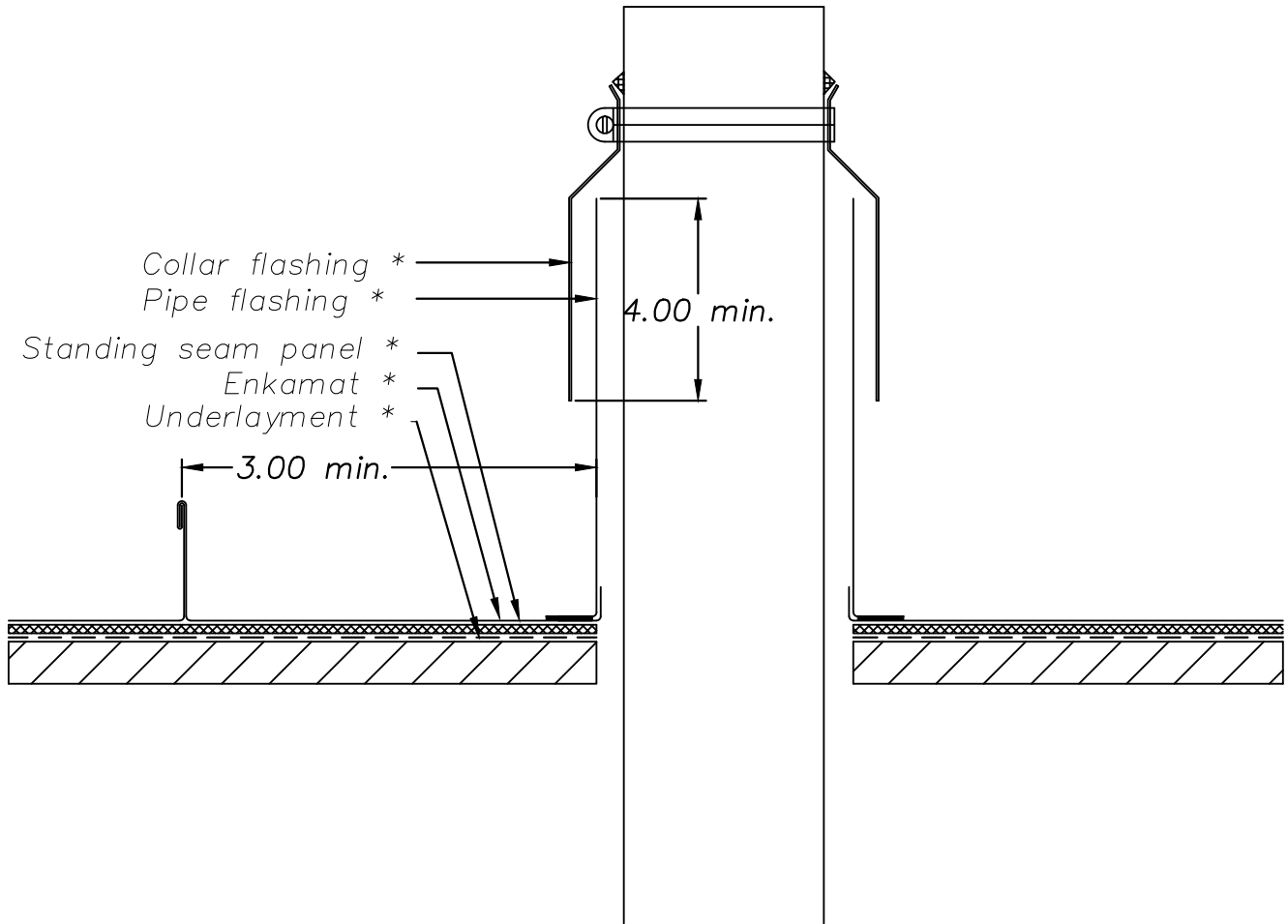

NOTE:
 Information and details are only a baseline for system and installation. Modification to meet project requirement is the responsibility of the designer, architect and contractor. MetalTech-USA project staff are available to assist throughout the design and build process. © 2011 MetalTech-USA. All rights reserved.

UNLESS OTHERWISE SPECIFIED DIMENSIONS ARE IN INCHES	DRAWING NAME: ROOF PENETRATION – OPTION 3		REVISION NO: A	DATED CREATED: 6/17/2015
	DWG NO: MT_SSRP_1903		CHECKED BY: ESIMONSEN	APPROVED BY: ESIMONSEN
				
PROJECT NAME: MISCELLANEOUS DETAILS				
SCALE: NTS	SHEET NO: 3 OF 6	SIZE: A	TOLERANCES: ANGULAR ±1° LINEAR ±0.06	

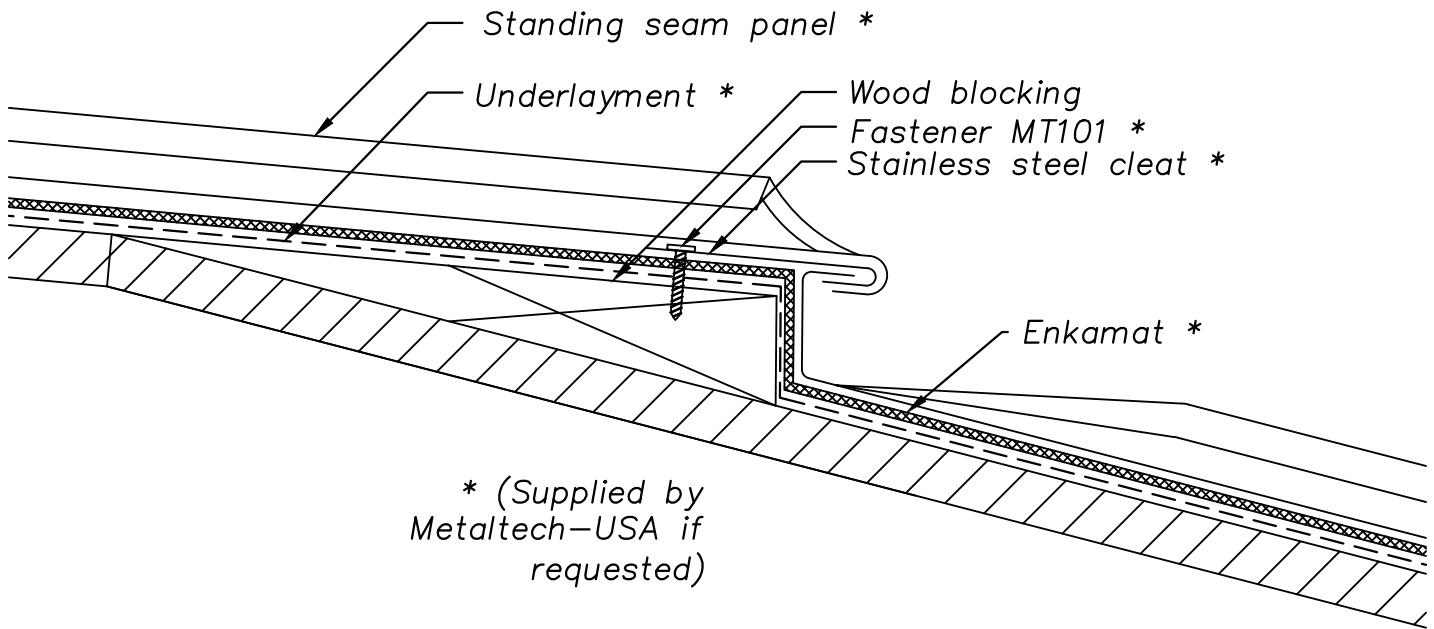

* (Supplied by Metaltech-USA if requested)

NOTE:

Information and details are only a baseline for system and installation. Modification to meet project requirement is the responsibility of the designer, architect and contractor. MetalTech-USA project staff are available to assist throughout the design and build process. © 2011 MetalTech-USA. All rights reserved.

	DRAWING NAME: ROOF STEP - OPTION 1		REVISION NO: A	DATED CREATED: 6/17/2015
	DWG NO: MT_SSRP_1904		CHECKED BY: ESIMONSEN	APPROVED BY: ESIMONSEN
	PROJECT NAME: MISCELLANEOUS DETAILS			
	SCALE: NTS	SHEET NO: 4 OF 6	SIZE: A	TOLERANCES: ANGULAR $\pm 1^\circ$ LINEAR ± 0.06

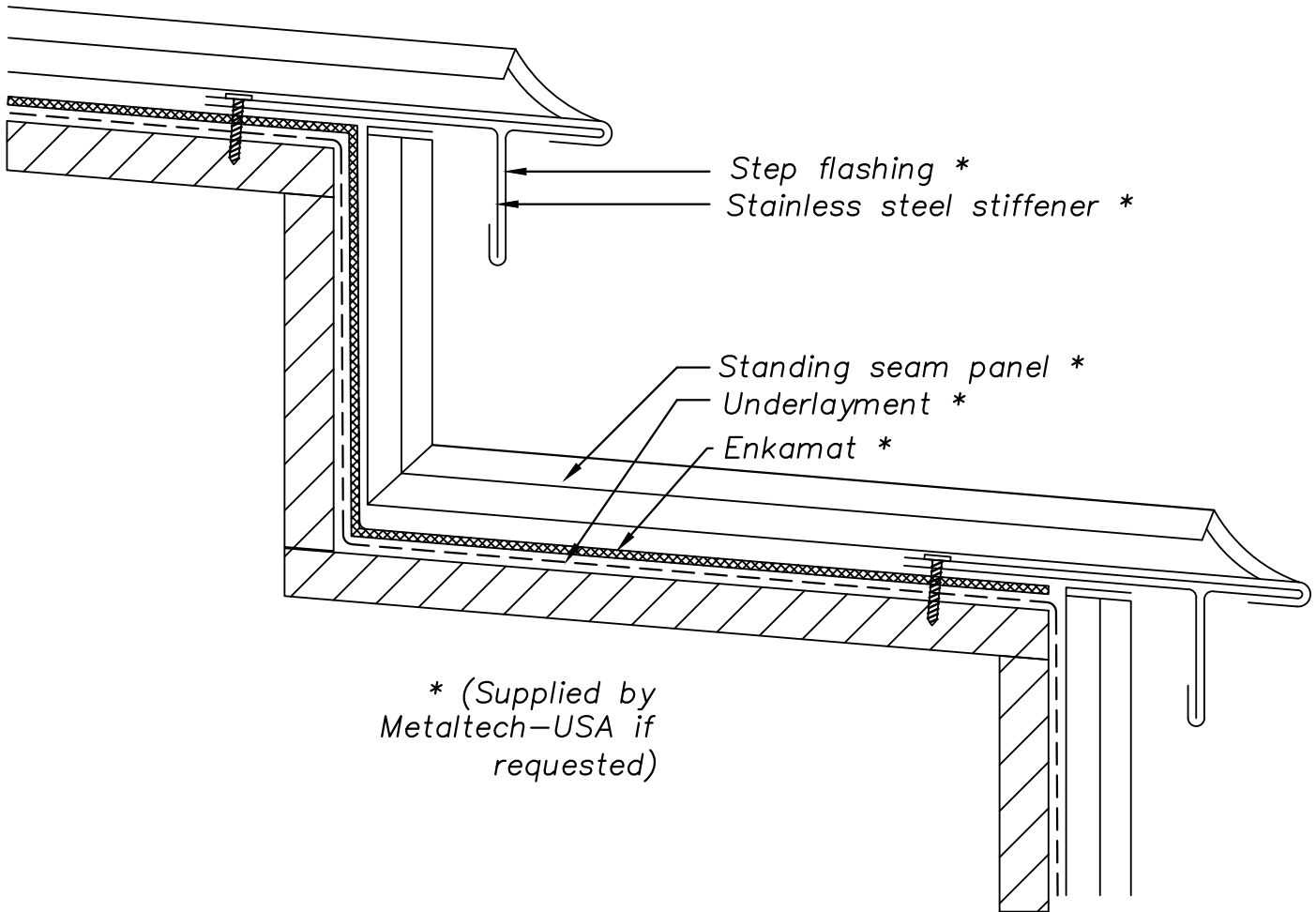

NOTE:
 Information and details are only a baseline for system and installation. Modification to meet project requirement is the responsibility of the designer, architect and contractor. MetalTech-USA project staff are available to assist throughout the design and build process. © 2011 MetalTech-USA. All rights reserved.

	UNLESS OTHERWISE SPECIFIED DIMENSIONS ARE IN INCHES		DRAWING NAME: ROOF STEP - OPTION 2	REVISION NO: A	DATED CREATED: 6/17/2015
			DWG NO: MT_SSRP_1905	CHECKED BY: ESIMONSEN	APPROVED BY: ESIMONSEN
	PROJECT NAME: MISCELLANEOUS DETAILS				
	SCALE: NTS	SHEET NO: 5 OF 6	SIZE: A	TOLERANCES: ANGULAR $\pm 1^\circ$ LINEAR ± 0.06	

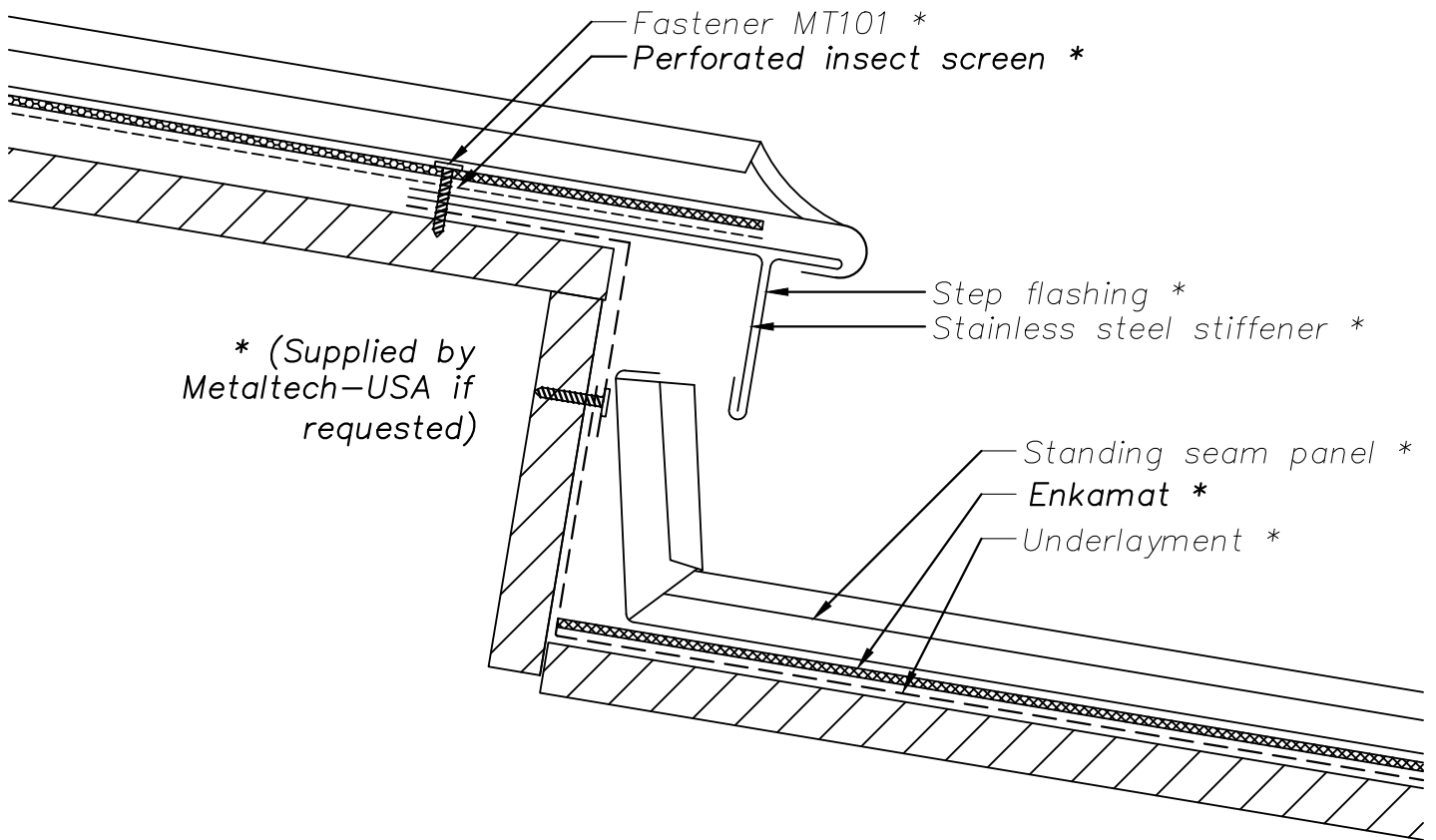

NOTE:
 Information and details are only a baseline for system and installation. Modification to meet project requirement is the responsibility of the designer, architect and contractor. MetalTech-USA project staff are available to assist throughout the design and build process. © 2011 MetalTech-USA. All rights reserved.

UNLESS OTHERWISE SPECIFIED DIMENSIONS ARE IN INCHES	DRAWING NAME: ROOF STEP - OPTION 3		REVISION NO: A	DATED CREATED: 6/17/2015
	DWG NO: MT_SSRP_1906		CHECKED BY: ESIMONSEN	APPROVED BY: ESIMONSEN
				
PROJECT NAME: MISCELLANEOUS DETAILS				
SCALE: NTS	SHEET NO: 6 OF 6	SIZE: A	TOLERANCES: ANGULAR $\pm 1^\circ$ LINEAR ± 0.06	